

AP-ART

A COMPENDIUM OF GEOMETRIC PUZZLES



BY
STEWART COFFIN

AP-ART

A Compendium of Geometric Puzzles

by Stewart Coffin



Copyright 2018 by Stewart Coffin

Front cover: *Jupiter* in zebrawood, Osage orange, tarara, blue mahoe, breadnut, and Honduras mahogany. Photo by John Rausch

In 2014, a 228 page preliminary version of this document was produced also titled *AP-ART, A Compendium of Geometric Puzzles*. Daughter Margie Brown did the page layout and arranged for 100 copies to be printed. John Rausch provided valuable help and later made it available electronically via Dropbox. For short, we have been referring to it simply as my *Compendium*. Its main purpose was as a comprehensive record of my puzzle designs listed by serial number, followed by name, brief description, and illustration. Often missing were construction details sufficient for woodcrafters to make reproductions, not to mention solutions. I have tried to correct that deficiency in this edition. Of course, also included here are my many more recent designs.

Related to the preparation of this edition, much of my effort took place in a makeshift woodworking shop where I strove to reproduce, as nearly as possible, a complete collection of wooden models of my many listed designs. One reason for doing this was to have a genuine permanent record of each one, especially where its printed description may be vague. A second reason was that I may have needed a model for more or better photographs. I have them all in storage now, destination undecided.

The plan this time is the reverse of before, with this electronic version first in 2018, possibly later followed by a printed and bound edition. This version is quite inclusive, whereas in a printed edition I might be inclined to edit out some that could be considered redundant or less inspired. When I shift from present to past tense in these descriptions, it indicates ones that I may have included mostly for the sake of completeness. Yet I probably made and sold a few of even those, and who knows but what they may have found a happy home. So I must take care not to disparage. You never know.

Acknowledgment

I owe the success of my puzzle enterprise, most of all, to my many hundreds of loyal customers scattered throughout the world, and the interest they have shown in my endeavors. Foremost among them has been puzzle expert and historian Jerry Slocum, author of many books and instrumental in forming a worldwide association of enthusiastic puzzle collectors. Nick Baxter has been a valuable source of information. I must also acknowledge the help of my resourceful wife Jane, now deceased, and our talented daughters, Abbie, Tammis, and Margie, for this was in many ways a family enterprise, especially during those memorable craft show years.

As for this *Compendium*, some of the ideas and material for it come from a somewhat similar publication produced and superbly illustrated by John Rausch in 2003, which he printed in limited quantity. I have recycled many of his excellent photographs. Other fine photos have been provided by Nick Baxter, Bob Finn, and James Dalgety. Many of these depict my designs reproduced by other woodworkers whose craftsmanship far exceeds mine, and I have tried to identify them as best I can.

My daughters have graciously made available their puzzle collections for me to photograph, even some long forgotten ones that I am delighted to rediscover and include. Other collectors have done likewise, especially Bob Finn and Jerry Slocum. Margie, with her expertise in electronic book editing and publishing, has again provided much needed help in transforming my raw materials into a more finished product.

Last but not least, for the essential final step of converting my rough draft into a format suitable for electronic publishing, I want to especially thank Margie and Valerie for their encouragement and expert help.

Contents

Part 1. The Plan	7
Part 2. Background	9
Part 3. Puzzles in Wood	19
Part 4. AP-ART Models	245
Part 5. More Designs in AP-ART	251
Appendix	301
Index	307



Part 1 - The Plan

This is my third book having to do with geometric puzzles. *The Puzzling World of Polyhedral Dissections*, published in 1990 and 1991, has been long out of print. Its more up-to-date sequel, *Geometric Puzzle Design*, published in 2007, was still in print as of 2018. It is primarily a guide to the systematic design and construction of such puzzles, organized by category and from simple to complex, explaining some of the theory behind their geometry, and with practical tips on making them in wood.

This work is different. It is an illustrated and annotated *Compendium* of the many geometric assembly puzzles I have designed and crafted in wood over the past fifty years, organized somewhat chronologically. One obvious difference is the inclusion of color photographs. Another is the addition of many new designs too recent to have been included previously.

The inspiration for this *Compendium* came to me quite suddenly in 2013 when I happened upon a beautifully illustrated book, *The Master of Illusions*, by Sandro Del-Prete. Why not produce something similar in my old age? What publisher could possibly resist it? As I immediately buckled down putting it together, I gradually came to the realization that publishers do routinely reject unsolicited manuscripts, as I should have learned all too well from previous experience. So why not self-publish, as I did from 1974 to 1991 with my *Puzzle Craft* magazine that gradually evolved into a 40-page book of sorts.

Accompanying each illustration are notes that I trust will keep the reader entertained and bemused. But beyond all that, I hope to imbue the reader with my passion for this captivating form of geometrical recreation centered around conjoined polyhedral shapes, made all the more attractive when crafted in fine woods. What other pastime brings into play so many different angles – geometry, combinatorial theory, logic, spatial perception, art and sculpture, fine woodworking, philosophy, and last but certainly not least – psychology. Surely it warrants a catchy new name added to our dictionary. So why not *AP-ART*, *the geometric art that comes apart!*

I never was in the habit of saving my own puzzles. I either sold them or gave them away as fast as I made them, and they are now scattered all over the world.

Consequently many of the photographs in this *Compendium* were supplied by others, without which it could not exist in its present illustrated form. The laborious task of editing the many photos and pasting them in allowed ample time to reflect on what I was doing. And why? This led in turn to many major revisions and fresh starts along the way, having to do with my intended objectives and how best to achieve them. The result: I decided to self-publish at least a first edition of my *Compendium* in 2014, both electronically and in printed form.

This expanded and improved edition of my *Compendium* is not likely to ever be a book that shoppers will find in bookstores and pluck off the shelf, attracted by the intriguing jacket design. It is intended primarily for devoted puzzle designers, makers, collectors, and solvers the world over, many of whom I include among my friends and former customers.

But then there are those who may be just getting started and would like to try making reproductions. Especially for their benefit, I have included detailed construction drawings, since the photos alone often reveal little if anything about the vital inner organs. Of course, better still would be having an actual model to copy. Listed in the Appendix are places where more design information may be found.

When I started producing wooden puzzles in the early 1970s, I was still devoting much of my time attempting to come up with puzzle designs to be manufactured in plastic. Since puzzle names can be confusing (especially mine!), I started assigning serial numbers to them. Little did I realize that fifty years later I would be trying to reconstruct them from scant records and failing memory. By 1985, that *Old Serial List* was up to number 66. It also included puzzles I hoped to license for manufacture, some perhaps more properly called polyhedral sculptures that come apart, plus topological puzzles, novelties, and even a few games. In 1985 I realized that my numerical listing was too much of a confusing hodge-podge and started all over again by numbering and listing, with a few exceptions, only wooden puzzles I seriously made for sale, with years made and quantity. That roughly chronological *New Serial List* serves as the basis for the organization of this *Compendium*.

Most of my numbered puzzle designs are illustrated, but a few photos are omitted because they would be unnecessarily repetitious. Some other photos are missing because they are nowhere to be found. Perhaps there will later be a revised edition to include some of the missing ones. Which brings up my grand plan for this work. Given the marvels of electronic editing, I envision this as an ongoing project, perhaps for as long as I am able, with additions and revisions as the fancy strikes me, and more important, correction of errors and omissions that are bound to crop up. Please point them out to me at stcmsd@aol.com.

Some of my numbered designs are too mundane to warrant much space in this *Compendium*, but I do give them just a few lines, without photo, for the sake of completeness. When I switch from present to past tense in the description it is my subtle way of dismissing them. Some of my design ideas did not get beyond the experimental stage, or may not even have been recorded, which accounts for gaps in the numbering.

Included in the descriptions of some of my designs will be found the note “An IPP exchange,” or something to that effect. The International Puzzle Party is an annual meeting of puzzle enthusiasts the world over. One of their activities is the Puzzle Exchange, in which each participant exchanges some new puzzle with about 100 of the other participants. I have often been called upon to provide the new design, and sometimes the 100 identical puzzles. Hence that notation.

My 2014 *Compendium* contained an expanded Appendix that included the following articles: *Square Root Type Puzzles*, *Interlocking Puzzles*, *Polly’s Flagstones*, *Psychogeometrics*, and *Rhombticks*. I omit them here, but perhaps they and a few others will later be made available again in some form or other.

Part 2 - Background

Since the organization of the book is roughly chronological, let's glance back to where it all began, on our living room floor in the early 1930s. My first plaything, fondly remembered to this day, was *Tinkertoy*. By the time I was ten I had moved on to Gilbert Erector Sets and various other mechanical devices, but in looking back now, I think the good old wooden *Tinkertoy* has a simple geometric appeal unmatched by any of the others. The length of sticks ingeniously increases by multiples of the square root of two, making possible geometric constructions with isosceles right triangles of various sizes.

My favorite amusements involved tools for inventing and constructing various mechanical devices. At an early age I made myself useful by developing a knack for repairing and putting back together things seemingly beyond repair. I also became interested in interlocking puzzles early on. The first that I remember were a set of three, probably made in the Orient and sold mail order for 10 to 15 cents each postpaid in the late 1930s by the old Johnson Smith Company of Detroit, Michigan, famed purveyor of marvelous amusements and novelties, and still in business today. I still have them.



This next photo, used for our 1941 family Christmas card, shows my sister and me assembling a jigsaw puzzle that I had glued up on a scrap of plywood and hacked out by hand using a coping saw. An early sign of things to come? The wintry scene is a photo taken by my father of our house in North Amherst.



A bit later I made some three-dimensional jigsaw puzzles from solid blocks of balsa wood.



Then there were those wonderful magazines such as *Popular Science* and *Popular Mechanics*, and even better – books on math and science. (If only I had saved some of them.) A college major in engineering was such an obvious choice for me that I don't believe it was ever even discussed. I graduated from the University of Massachusetts, which was within walking distance of home, in the class of 1952 with a degree in Electrical Engineering.

For the next ten years I was employed in the electronic industry and paid well for doing practically nothing of any importance, first at MIT Lincoln Laboratory and then at Mitre Corporation. Toward the end of that decade, during the day I was wasting away my time and energy as Head of Engineering at Dynamic Controls Company in Cambridge, while during the evening and weekends I was experimenting with making fiberglass whitewater kayaks in our basement, using epoxy and polyester resins. That soon developed into a cottage industry. When we moved from cramped quarters in Arlington Heights to our nine-acre property in Lincoln in 1964, I quit the commuter rat race and put away for all time my business suit and tie and all the other trappings of the corporate world. I guess you might say I then went to the other extreme.



Our Lincoln property had been a large nursery recently abandoned. I converted one of the greenhouses with attached office building into a makeshift workshop.



At the same time I found myself suddenly launched into the business of growing trees and shrubs in my spare time. Later, assisted by my faithful and ever resourceful wife Jane and our three gardening daughters, Abbie, Tammis, and Margie, we also grew organic fruit and vegetables and sold the surplus. This photo of our farm stand appears on the cover of my book *Tipcart Tales*. One of our visitors, evidently impressed by our rustic subsistence style of living, so seemingly incongruous within the very upscale community of Lincoln, gave us a copy of *Living the Good Life* by Helen and Scott Nearing, which tells about their somewhat similar homesteading endeavors but in rural Vermont. I think the title of their book pretty well sums up our own family life for those years.



In the 1960s I also developed and was manufacturing what were probably the first practical composite canoe and kayak paddles made of epoxy, S-glass, and aluminum. In this photo by my father I am bolting together the two halves of the cast aluminum mold, with a sandwich of fiberglass and epoxy being pressed together around the aluminum shaft covered with resin-coated knit sleeving. Up to eight blades were cured for two hours in the electric oven on the left. The drum in back held five gallons of a noxious chemical.



It never ceases to amaze me how some incident that seemed so trivial at the time can change the whole direction of one's life. (Perhaps I should have put "direction" in quotes because my life seldom had much actual direction. It has just drifted merrily along its way, nudged to and fro mostly by circumstance.) Around 1968 I decided to quit working with fiberglass because the horrible chemicals (benzene, styrene, acetone, and aromatic amines, to name just a few) were making me ill, and I now consider myself fortunate to still be alive. I wasn't quite sure what I might do next for income, but some inspiration was sure to come at any moment. With a strong family background in art, one day I decided to try crafting some geometric sculptures. And here is where the story becomes more interesting.

I have had a lifelong interest in mathematical recreations. Around 1950 my father gave me a copy of *Mathematical Snapshots* by Hugo Steinhaus, and there was one intriguing chapter on polyhedra in that wonderful book that captured my imagination. I had been especially intrigued by the rhombic dodecahedron, and now eighteen years later it all came drifting back to me. So I played around with it for a bit and discovered that the rhombic dodecahedron could be enclosed by a cluster of twelve triangular sticks. (Photo is of a model made much later.)

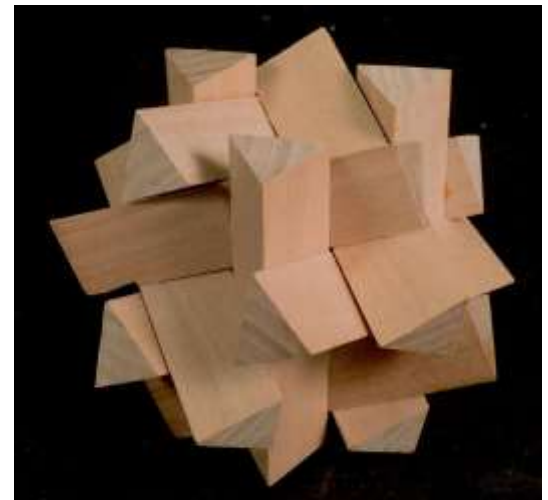

This led in turn to interlocking notched hexagonal rods. I decided to try casting some in epoxy left over from the paddle works. Our neighbor Fred Wilfert, a skilled machinist, expertly milled a pattern from $\frac{3}{4}$ -inch hexagonal steel rod, from which I made Silastic RTV rubber molds. Shown here is one of my original 1968 models, cast in epoxy and pigmented in four colors.



It is interesting to note that this started out as an intriguing geometrical sculpture, and the potential as an interlocking assembly puzzle was an accidental afterthought. One day our oldest daughter Abbie took one to school to show her friends, and it caught the attention of the Town of Lincoln children's librarian, Heddie Kent. That led in turn, through a complicated series of connections now forgotten, to my contacting Thomas Atwater in nearby Concord, whose unusual profession was as business agent for puzzle and game inventors. Out of this partnership came a license agreement with 3M Company to manufacture my *Hectix* and market them in stationery stores as upscale (\$5.00) puzzles.

I always have to add this one amusing anecdote: The contract for molding them in styrene was given to nearby Nylon Products Corporation (now Nypro). The pieces were spewing out of their injection molders rapidly enough, but the task of assembling them using chemical union workers proved too costly. When an emergency meeting was held at their plant in Clinton, I proposed a solution. Ship the parts to my plant in Lincoln, and we would assemble them for four cents each. What they didn't know was that my "plant" consisted of a picnic table on our back lawn, and that my work force consisted of our three little girls on summer vacation. I paid them two cents per puzzle, so everyone came out ahead.

Soon their playmates learned of this bonanza and joined in. At the end of a few weeks, a truck rolled down our driveway with 20,000 assembled *Hectix*. We would gladly have done more, but evidently the job then went elsewhere, for whatever reason.

One of the charms of *Hectix* is that it requires little dexterity to assemble. The first three pieces nest snugly together on the bottom, and the next three pieces are exactly the right length to stand vertically in place, ready to hold the remaining pieces. I would like to take credit for that clever design feature of correct length, except that it was probably accidental. The elves averaged doing about two puzzles per minute, and after a while they barely paid attention to what they were doing. That gave me an idea. When we were invited to appear on the Tom Colton TV show on Channel 22 in Springfield, the final act would be Abbie assembling a *Hectix* blindfolded. It was a bit risky because back then such shows were live, not recorded. But Abbie came through with time to spare.

Geometric puzzles of the type described in this *Compendium* tend to be more satisfactory if they do not have the distraction of demanding great dexterity. That may seem like a strange comment when you come to several of my so-called coordinate motion puzzles, where two or more pieces must be manipulated simultaneously. But that sort of mechanical action can be fascinating to play with (and fun to design), and where appropriate I provide helpful hints and even assembly jigs to hold the pieces in place and guide them together.



Hectix was supposed to be made in four colors like my prototype. It had three different mechanical solutions, which could be defined by the attractive symmetrical arrangements of color. But for some unknown reason, 3M never made it as intended but rather in white or randomly assembled red, white, and blue, plus a few of their “executive line” in clear acrylic with embedded bubbles that sold for \$10.



After I obtained a patent on the design, I learned that Bill Cutler had invented a similar but slightly different version around the same time, but his never went commercial. As I recall, about 100,000 *Hectix* were made and sold, for which I received a royalty of around ten or fifteen cents each. That was probably more than I made my last year in the paddle business, so on the strength of that I decided to liquidate my stinky fiberglass business and try my hand at inventing unusual geometric puzzles.

My sequel to *Hectix* called *Frantix* was likewise injection molded in styrene and sold by 3M a couple years later, but nowhere near as many. It had slightly tapered pins and holes, so did not slide together smoothly. You need a knife to pry apart the one shown here. Possibly because of patriotic fervor surrounding the upcoming 1976 Bicentennial, 3M made it likewise in red, white, and blue. But as you can see, it too has colors assembled randomly rather than symmetrically. (My trusty elves could have assembled them properly at our “plant,” and probably cheaper too.)

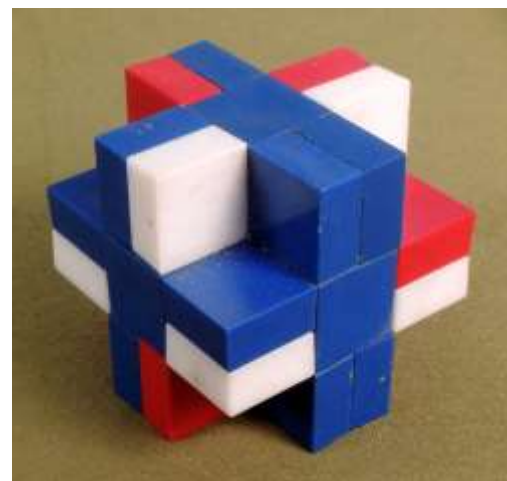

From 1968 to 1970 I continued to experiment with cast epoxy models in hopes of getting some licensed for manufacture. The first of these was *Spinner* (left), so named because it refuses to come apart until tossed into the air with a slight spin, when it flies apart. The first version consisted of six identically shaped pieces in three colors, two of each. There was also a four-color version in which the two halves of each piece were of different color, the object in both versions being to assemble with color symmetry. About a dozen were made.

The *Z-Puzzle* (right) consisted of 12 nearly identical Z-shaped pieces, likewise cast in multicolor, which assembled to form a truncated rhombic dodecahedron. Only a few of this uninteresting design were cast.

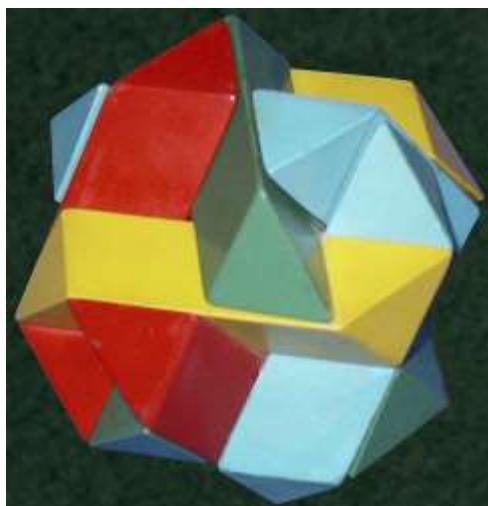

Prism (left) consisted of six identical pieces, cast in three colors, which assembled to form three intersecting square prisms. This was later the basis for my *Seven Woods* (#42). Only a few were cast.

Pluto (right) was a slightly more interesting version of *Prism*, in which each piece had a shoulder at one end, making the assembled end faces octagonal rather than square, and blocking all but one axis of assembly. Only a few were cast.

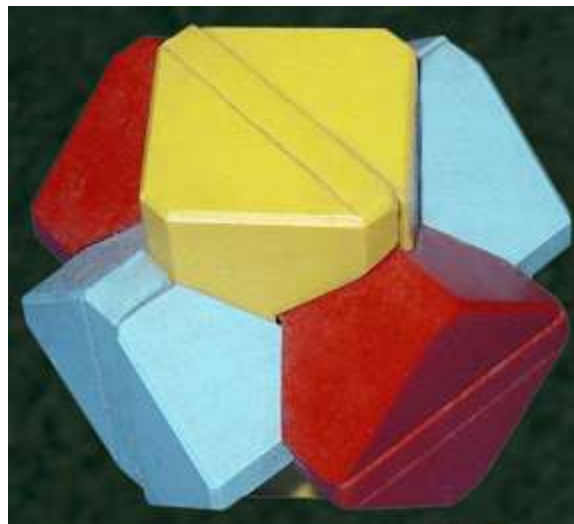
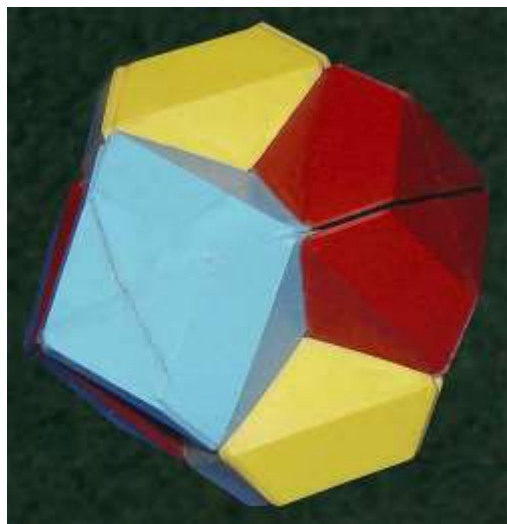

Octo (left) was similar to *Prism* except that each piece was bifurcated longitudinally, making 12 pieces. It used four colors with associated color symmetry problems. It was an exercise in dexterity to assemble. One version had a split piece for easier assembly. The assembled shape suggested an octahedron. There was also a three-color version. Only a few were cast, but a modified version later led to my baffling *Three Pairs* (#27).

Four-Color Cube (right) consisted of 12 cast pieces, three of each color, which were to be assembled into a cube with four colors on each face. (Photo shows one assembled incorrectly.) There was also a slightly more interesting version in which the pieces were joined in pairs to make six bi-colored pieces. Only a few were cast.



Four-Color Octahedron (top photo) was similar to *Four-Color Cube* except octahedral when assembled, also with 12-piece and 6-piece versions. Only a few were cast.

Then around 1971 Nylon Products decided to get into the puzzle business themselves. They asked me to design a line of simple puzzles to be called *Geo-Logic*. To reduce mold costs, all six pieces of each one had to be identical and thin-walled, which unfortunately greatly limited the possibilities. For the first puzzle in their *Geo-Logic* line, *Tauri*, all Nylon Products had to do was make a copy of my *Spinner* (second photo) that I had so laboriously tried to cast in epoxy.

Tetrahedron (no photo) was similar in principle to *Prism* except that the assembled shape was tetrahedral. It later became the prototype for the plastic *Cetus*.

We have John Rausch to thank for locating so many of these early cast models and photographing them. It all seems like ancient history to me now. He also sent me yet other photos of models long since forgotten, and I can't imagine how and where he managed to find them all. There must have been many other experimental models cast during this phase but not recorded and either discarded or otherwise lost.

Some of my models became the prototypes for other puzzles in the Skor-Mor *Geo-Logic* series, such as their *Nova*, *Spirus*, *Aries*, and *Uni*. Most of my models were epoxy, but a few were wood painted to simulate plastic, such as this model of *Aries*. We often see plastic colored to imitate wood, but how often do you see wood painted to look like plastic?

Uni (no photo) enabled two or more puzzles to be joined together like molecules. Some puzzles had pieces interchangeable with each other, which allowed assembling different combinations of pieces and exploring for new geometric possibilities. There was one called *Double Star* that could be assembled inside out to form an alternate shape.

They were molded of styrene in various colors. Many were made in translucent primary colors and had the novel property of the secondary colors appearing by transmission of light, especially *Cetus*, the triangular pyramid. Shown here are four of them – *Spirus*, *Cetus*, *Aries*, and *Double Star*.



Later I heard that the *Geo-Logic* line of puzzles had been sold to the Samuel Ward Company of Boston, but by that time my involvement had ended.

For the sake of being complete, before proceeding to the numerical listing, I will briefly describe just a few of my early experiments in wood that never made it into production.

In 1973 I came up with a variation of the familiar old *Three-Piece Cross Puzzle*, with two loose blocks inside, and made a few. Later I made what I think might be considered an improved design, with three dissimilar pieces plus one loose block inside, which must be jiggled into an unlikely place to permit disassembly. This puzzle has been designed and produced independently in Japan under the name MINE's COG Puzzle.



Wunder Bar consists of six pieces that fit together to form a cubic lattice. There are four types of pieces. Each piece is made up of three $1 \times 1 \times 5$ sticks joined together. There are four distinct mechanical solutions, but by using multi-colored woods and requiring color symmetry, the number of solutions can be reduced, as in the first photo. In the second photo, each piece is a separate color for purpose of illustration. Red and orange are identical, likewise blue and purple. Yellow and green are mirror image. Only a few were made in 1973, but now add this painted model made recently for the camera.



Cube Brute consists of 24 identical simple burr pieces that interlock to form a symmetrical cubic-shaped assembly. The final step of assembly is the tricky mating of two halves by rotation. There is also a 16-piece square solution that assembles by sliding two halves together. A couple sets were made in 1973, and now this one recently in mahogany.

Pentangle came up with this independently around the same time and sold it as their *Woodchuck Puzzle*.

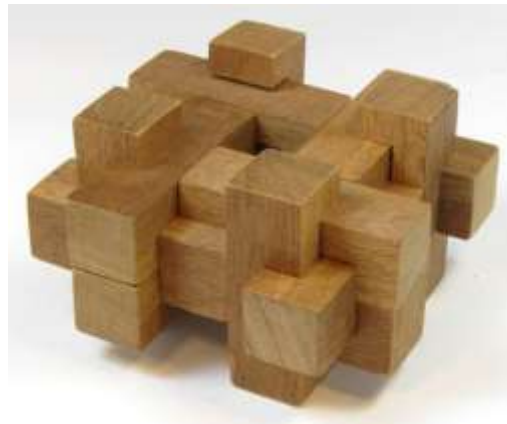

Triful was designed in 1973 for production in plastic, and a few models were made of wood painted in four bright colors to simulate plastic, but it was never produced. It consisted essentially of 12 triangular sticks with end blocks added, in four colors, three of each. Four pieces, one of each color, were cut in two to permit assembly. An improved version was designed around 1975 that used four sliding key pieces instead of divided pieces, but only one or two were made. Much later this design was resurrected to become the basis for my *Isosceles* (#101) and *Iso-Prism* (#101-A).



In 1970, with things going very slowly, I decided that a more reliable source of income might be making my own original puzzles to sell, with the emphasis on interlocking geometric solids. So I did just that by converting our old greenhouse once again, this time from epoxy paddle factory to woodworking shop. And that is what Part 3 of this *Compendium* is about.



Part 3 – Puzzles in Wood

1. Ortho-Cube. This was a non-solid semi-symmetrical 12-piece dissection of a 5x5x5 cube, crudely fashioned of 7/8-inch square birch stock and selectively “stained” (if you could call it that) by heating certain parts with a blowtorch! It appeared on my very first brochure issued in 1970. In looking back, I wonder how I expected anything as poorly made as that to sell, even at the \$8.00 price, but evidently they did, for I don’t find any still around now. Thus you are spared a photo of it. Its only claim to fame: being first on the list.

1-A. The Cube. This is an improved version of *Ortho-Cube* made with 3/4-inch stock in three contrasting woods. It has three kinds of pieces, four of each. It appeared on my 1971 brochure. It was later reproduced by Pentangle in England and called *Wookey Hole*. This model is in oak, blue mahoe, and tulipwood.

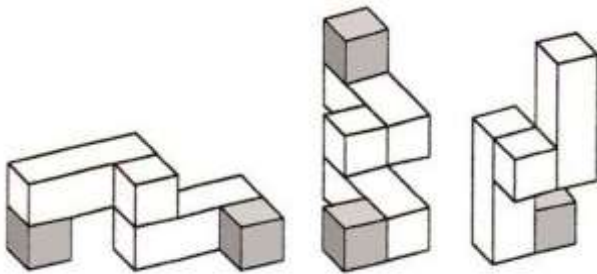

2. Pentablock. As nearly as I can determine, this is one of only three listed that are not my original designs, the other two being *Sirius #4* and *Square Knot #9*. (But I suppose, on the other hand, that everything we do along these lines is based in part on ideas and principles that someone has developed before, going all the way back to the famed mathematicians of ancient Greece). This is the familiar set of 12 solid pentominoes, so-called, which are dissimilar puzzle pieces made of five cubic blocks joined flat all possible ways, and packed solid into in a 3x4x5 box. A few of this early version were made of 7/8-inch birch. It too was listed on my 1970 “brochure.” That first crude sheet probably says a lot about my funky notions of operating a business, which some say I never managed to go much beyond. But of course, back then who could possibly have imagined where it would all lead?

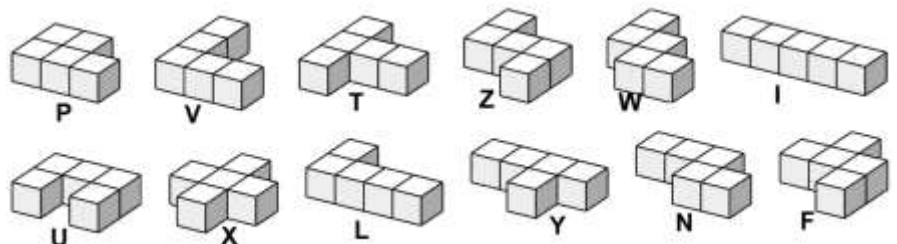

2-A. Pentablock. The next version of was made of $\frac{3}{4}$ -inch hardwood stock and contained in a Plexiglas box.



2-B. Pentacube. This is a much improved version made of 12 colorfully contrasting woods and packed into a box of $\frac{1}{4}$ -inch blue mahoe.



Which brings to mind my blue mahoe story. In my quest for more colorful woods, which I will discuss in more detail later, I was looking for a bluish wood, which was no easy thing to find. But I had heard of one called blue mahoe that grew especially on the island of Jamaica. An inquiry to their Chamber of Commerce revealed that yes indeed it grew there, but it was in such demand by their local craftsmen that there was an export embargo on it. So that was the end of that, or so I thought. Then in 1975 I heard that Marshall, an importer of tropical woods, was having liquidation sales, so I drove down to their dumpy lumberyard, located in a creepy waterfront area somewhere near the Brooklyn Bridge, to have a look. Exploring their dusty and dimly lit warehouse by flashlight, I discovered a large bale of veneer that looked promising, so I broke off a piece to bring back home. I sent it to the USDA wood laboratory in Madison for identification, and it came back sure enough blue mahoe. I negotiated by phone with Marshall a price of a dollar a pound plus shipping for the entire 500-pound bale. When it arrived by truck, I was dismayed to find that only the top few layers were quarter-inch blue mahoe, and the rest was a mixture of $\frac{1}{8}$ -inch veneer of English brown oak and holly. When I proposed to return it, Marshall lowered the price to an amount I could scarcely refuse. The holly was so rotten that we used it for firewood, but I sold enough of the oak to recover my purchase price. I have used the blue mahoe sparingly for many years and still have a couple boards left. In addition to the distinctly dark blue-green color, it is beautiful wood to work and makes excellent boxes.

3. Snowflake. It started out being manufactured in plastic and ended up crafted in wood. The idea for the set of ten *Snowflake* puzzle pieces came from Martin Gardner's column in *Scientific American*, June 1967. I added the tricky base, and with help from my children generated dozens of geometric or animated puzzle problems.

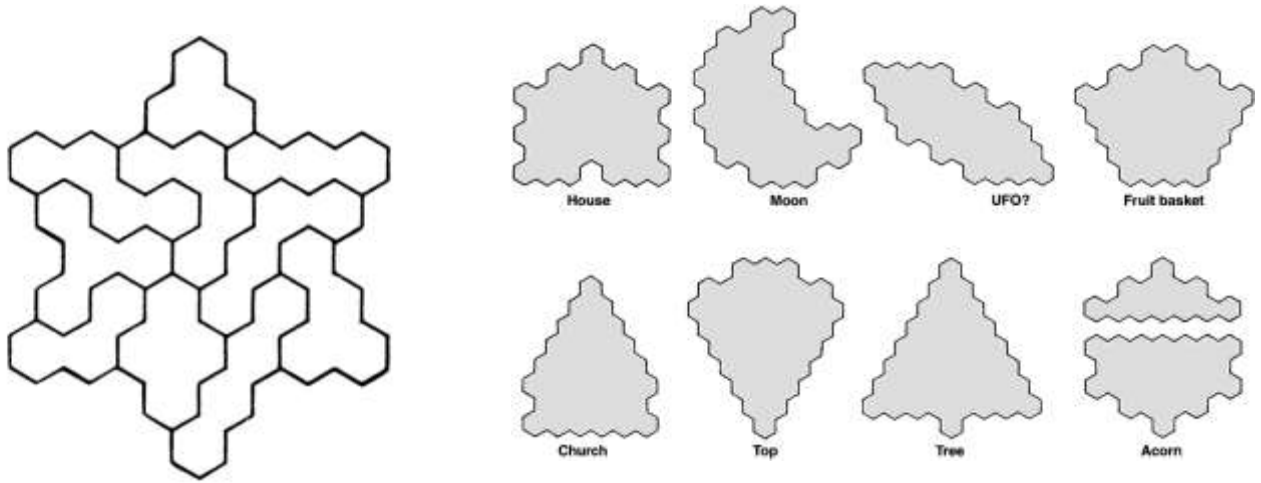

I first cast the pieces and base in epoxy using Silastic RTV molds. I see that it too was included in that first crude sales brochure. For a while around 1971, thin and rather misshapen *Snowflake* puzzles were cast in polyester by Span Products Inc. of Paterson, New Jersey, and sold at the Museum of Modern Art in New York. Later, perhaps inspired by the venerable Anchor Stone puzzles of Germany, I switched to casting thicker pieces accurately in brick-colored Hydrastone.

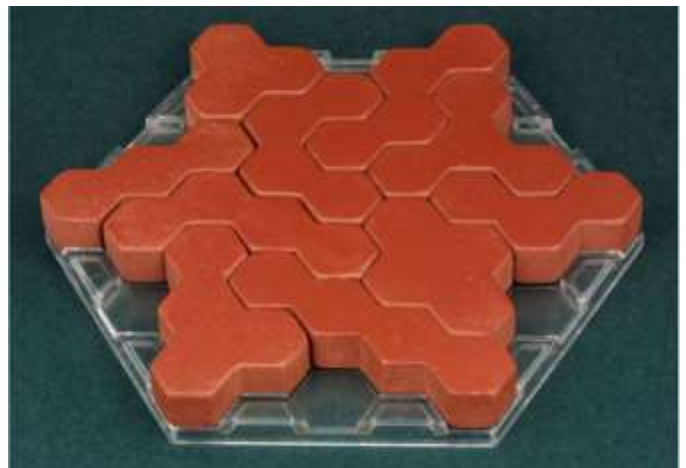

Still later, Jim Ayer cut some sets from thin plywood by water jet at his jigsaw puzzle factory in Marblehead, Massachusetts. Some were also die-cut from foam by Binary Arts. Others have been cut by laser.



On the left is a version in cast polyester marketed by Small Wonders. Finally I made a few well crafted *Snowflake* puzzles in mahogany, sawed from hexagonal sticks and joined together with glue, and with a wooden tray with cover (right).

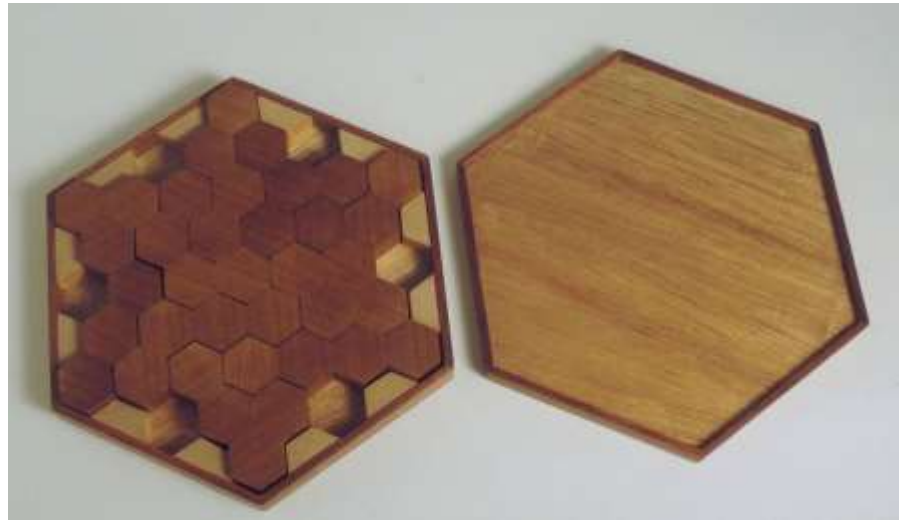

4. Sirius. The six identical *Sirius* pieces assemble in two mirror image halves of three pieces each to form the familiar first stellation of the rhombic dodecahedron. It is not my original design, but my innovation was gluing up the individual pieces from three blocks, with their grain oriented such as to make them more durable.

Blocks used in construction of puzzle pieces will be found identified by letters throughout this *Compendium*. Here **T** means tetrahedral block and **C** is six-sided center block. An explanation of their geometry and fabrication is given in the Appendix.

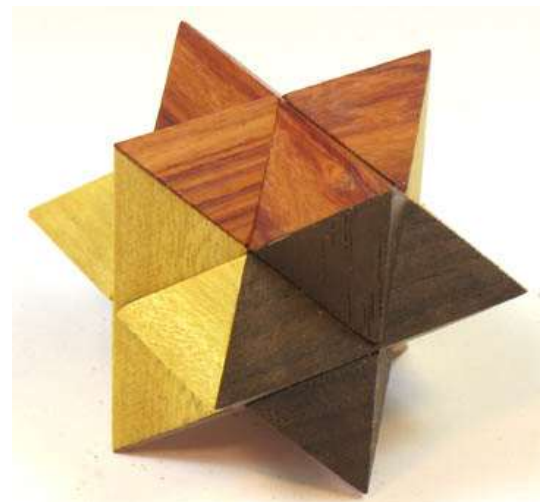
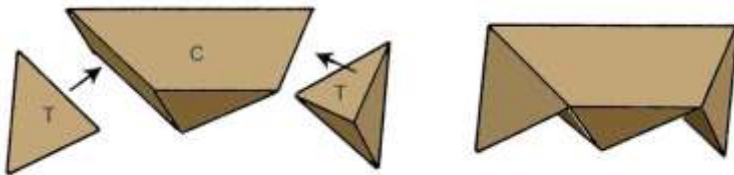

4-A. Star. This is a larger version of *Sirius* made with 1.25-inch stock. I used three contrasting fancy woods combined in a way such that the puzzle could be assembled two different ways with color symmetry, as shown by this and the previous model. For a bright yellow wood I hit upon Osage orange. It was supplied to me by a lumber company in Ohio, where I presume that it grew. Note direction of wood grain.

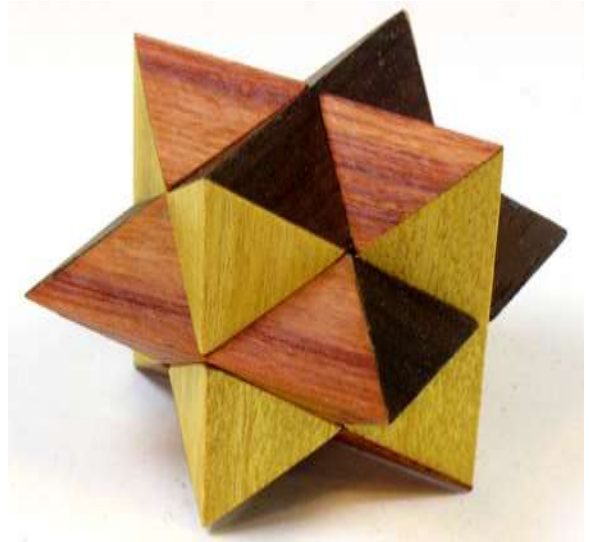

All of these polyhedral constructions require special jigs to hold the parts in place while being glued. This simple glue jig for *The Star* is used for many more to follow such as #6, 8, 11-16, and dozens of others.

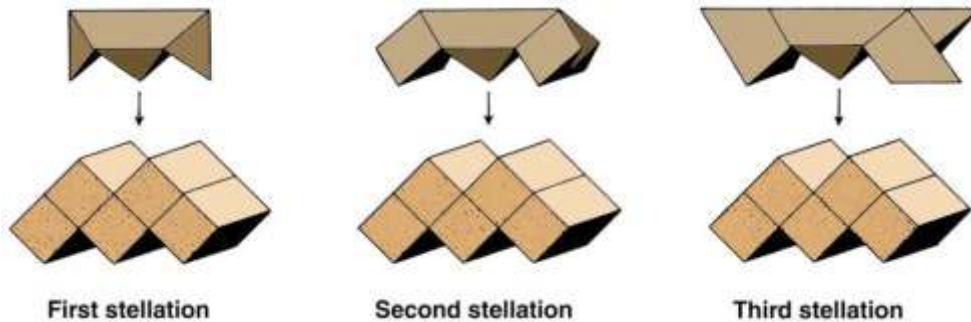

5. Spider–Slider. Here is another of my very first year’s operations in wood. Evidently I made just a few of crudely stained basswood in late 1970. I had forgotten, and we probably never would have had this photo except for an extraordinary happenstance. While on a local outing club hike in 2012, I had the extreme good fortune to recognize Marie among the group, my long-lost friend and outing companion of over forty years past. While both of us had been assuming that we lived thousands of miles apart, we had been living unawares within a mile of each other for nearly a year. To add to my surprise, Marie told me she had one of my puzzles. It proved to be one of those early basswood *Spider-Sliders* that she had bought (for \$10 we are guessing) during a visit to my shop those many long years ago. So double good fortune! I have enhanced some of the faded colors for this photo.

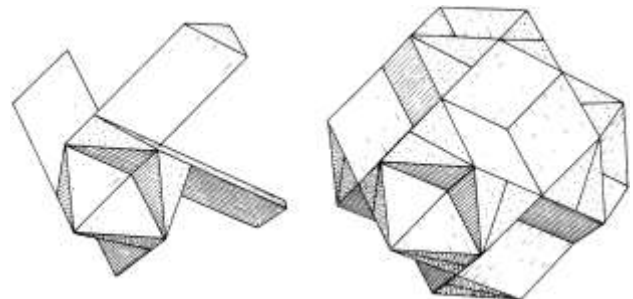

5. Scorpius. This is an improved version of the *Spider-Slider*. The problem with stained basswood was that it looks like – well – stained basswood. Why not instead use four dissimilar attractive hardwoods with a natural finish. It is so simple to assemble as to be more of a polyhedral sculpture than a puzzle, but an added amusement is to discover the four different ways to assemble it with color symmetry. When assembled it feels solid, yet when tossed with a slight spin it flies apart in all directions.

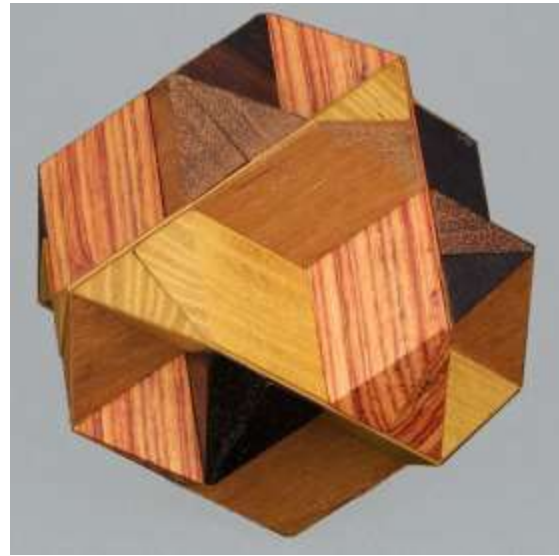

6. Four Corners. This is the first in a long and seemingly unending family of designs that start with the basic *Star* geometry, with parts then added on judiciously. It is made in four contrasting fancy woods plus a fifth for the center blocks. Here in tulipwood, oak, purpleheart, and rosewood, with center blocks of poplar. When assembled correctly, each “corner” is one kind of wood. **R** indicates right-handed prism block (see Appendix). In the second drawing, the permuted numbers stand for different colors. An IPP exchange.

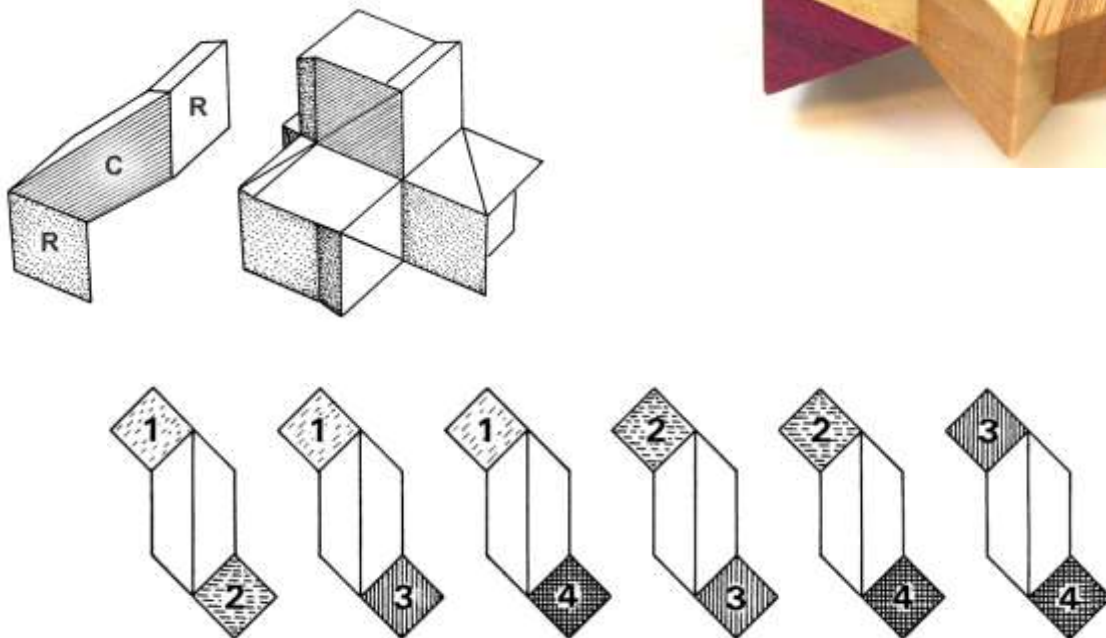

7. Jupiter. After having explored many variations of the basic rhombic dodecahedron geometry in addition to those already mentioned (with many more yet to come), the natural next step was to proceed on to the 30-faced rhombic triacontahedron. I discovered that it could be enclosed by 30 nesting sticks of 36-36-108 degree cross section, but if I actually made any such model way back then, I have no record or recollection. In my previous books I used just a drawing, but now here is one in the flesh, made recently.



Splitting each of those thirty triangular sticks in two, shortening them, and joining them in fives produces a simple but elegant 12-piece puzzle analogous to the *Scorpius*. Again the mechanical solution is not difficult, but it is made of six dissimilar woods, and the added novelty is discovering the five solutions with color symmetry. I usually made my own gluing jigs, with special attention to accuracy. The jig for *Jupiter* proved too great a challenge, and so the base for it was made for me by expert machinist Hal Robinson using a Bridgeport milling machine with rotary table, with the same angles as the vertex of a triacontahedron. It has been copied many times. Note doweled joints below, done frequently but not always.



But what to use for the required six contrasting fine woods? This led into a whole new world of exotic woods, and was just one more of the many rewarding aspects of this journey of discovery. I joined the International Wood Collectors Society and bought several books, the most useful of which was *Commercial Foreign Woods on the American Market* by Kribs. I amassed a collection of well over 100 of their standard 3x6x1/2-inch wood samples and sometimes put them out for display at craft shows. Throughout this book I use common names for woods rather than scientific names, since this is intended to be the story of my craft rather than a scholarly treatise on botany. Furthermore, when using the scientific names, you want to be sure they are correct. I was not always sure, and even my commercial suppliers sometimes made mistakes, whether unintentional I was also not always sure. With common names you enjoy a bit more leeway! In the photo on the previous page, the dark wood is that precious blue mahoe. If you look closely, you may be able to see that it was made from three layers of those 1/4-inch boards laminated together.

Jupiter was used as the centerpiece of our display at craft shows and became the one puzzle by which my craft was most often identified. I made and sold them by the hundreds, and people would sometimes report seeing one somewhere. There is an amusing story about our craft shows. With a crowd gathered around our booth, I would gently flip the *Jupiter* into the air and it would fly apart into its 12 pieces. I would announce that anyone who could put it back together could have it. Seldom would anyone try for this prize, and I never had to give one away. Meanwhile our daughter Margie, then about nine, would be planted in the crowd and be making her way to our booth. After puzzling over it for a bit, she would deftly put it together, with color symmetry to boot, while I was occupied elsewhere. I could recognize the hollow sound of the final step as the two halves popped together, as well as the laughter of the onlookers as she tucked it under her arm and blithely sauntered off. Usually a few of them would catch on and ask if by any chance she happened to be my daughter. We worked it over and over.

For many years, *Jupiter* was listed on my sales brochures at the same price of \$25. But most of my sales in the early 1970s were wholesale and the standard discount for stores was 50%, so I netted only \$12.50. Then around 1972 I got sucked into a contract to make several hundred *Jupiter* to be sold to Book-of-the-Month Club through a wholesaler. I hired a high school boy, Brad Hardie, to do the gluing at home and paid him \$1 per puzzle, hence the initials BH inscribed on the inside of many. I was paid only about \$9 each for those. Later, when many of them remained unsold by Book-of-the-Month Club, they offered to sell them back to me at their cost of \$12.50, which I accepted. By that time I had a thriving mail-order business, thanks to an article by Martin Gardner in *Scientific American*, so I resold them for \$25 and everyone was happy.

8. Nova. The six identical symmetrical pieces of *Nova* assemble easily to form the second stellation of the rhombic dodecahedron. In fine woods, it too is more of a polyhedral sculpture than a puzzle. I made many in boldly striped zebrawood, but this well crafted reproduction in exotic woods is by Lee Krasnow.

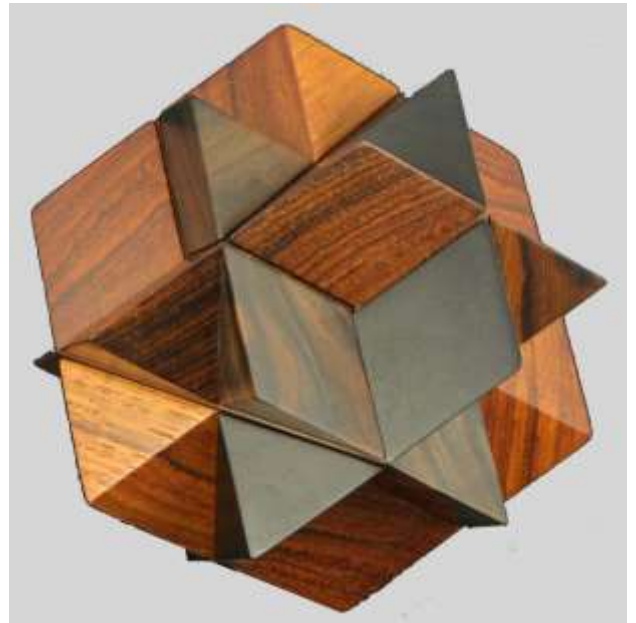
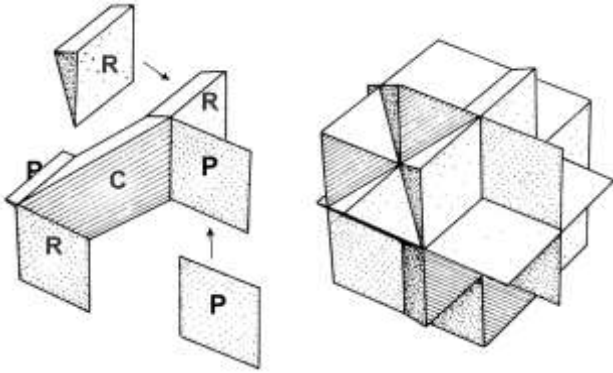

8-B. Nova. This was a fancy version of *Nova* in four contrasting woods, the object being to discover the three different ways of assembling with color symmetry. In the drawing, the numbers indicate different woods. Note the dotted line axis of symmetry.

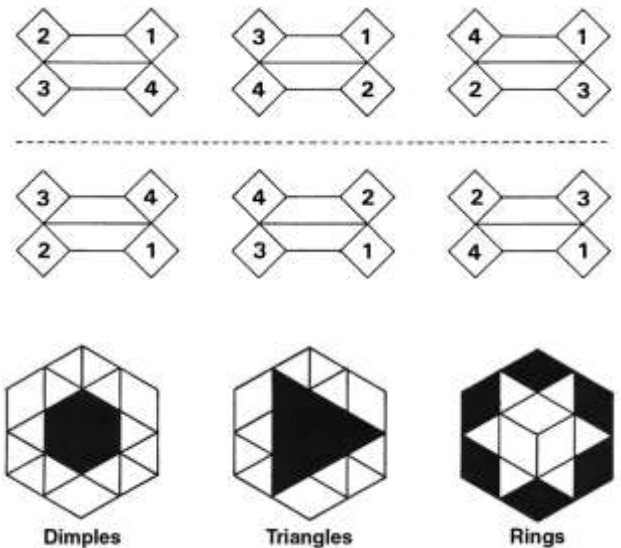

9. Square Knot. That is my name for this popular old classic puzzle and one of the few in this book not of my design. It was patented in 1890 by William Altekruise. As a result of some genealogical research, I found that the Altekruise family is of Austrian-German origin. Curiously, the name means “old cross” in German, which has led some authors to incorrectly assume it was a pseudonym. A William Altekruise, who I am guessing was the grantee of the patent, or possibly a relative of, came to America in 1844 as a young man along with his three brothers to escape being drafted into the German army. Could he have perhaps brought at least the germ of the idea with him? The puzzle consists of 12 identical notched square sticks and has an interesting solution involving the surprising mating of two identical subassemblies. There are three solutions identified by being able to come apart on one, two, or all three axes. It has many interesting variations, some of which will appear later in this *Compendium*. I made 40 them, 1974-1975, from 7/8-inch-square sticks, often in three contrasting woods

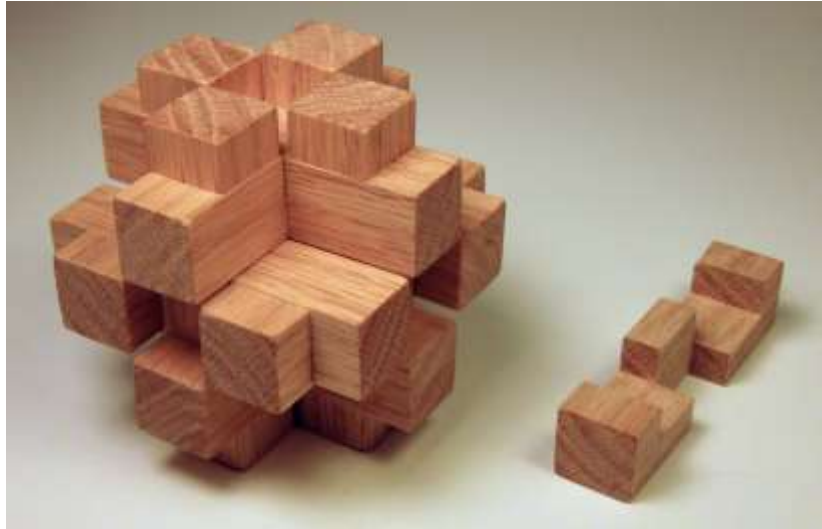

This more recent model in 3/4-inch oak is demonstrating the final step of assembly, as the two identical halves mesh together



These two photos demonstrate some of the many other interesting variations that are possible, without limit.



9-A. Frantix. This is a variation of *Square Knot* with pins and holes in place of notches. 9-A designates my original wooden version designed as prototype for 3M's plastic version mentioned in Part 2. This reproduction beautifully crafted in redheart and maple was made by Interlocking Puzzles for use as an exchange puzzle at one of the annual International Puzzle Parties, where collectors swap new and unusual puzzles with each other. Many other puzzles shown in this *Compendium* have found their way into the IPP exchange, an abbreviation that will occur frequently in what follows.

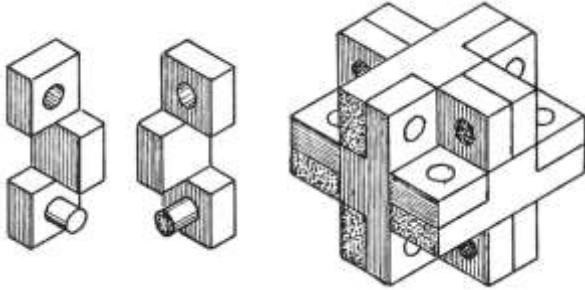

9-C. Frantix. This improved version of *Frantix* has extra holes and pins in the centers, resulting in four kinds of pieces, three of each. Many other interesting variations are possible.

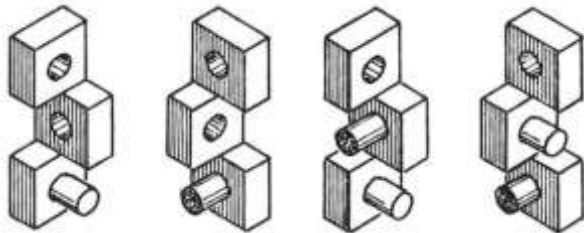

9-D. Super Frantix. This 14-piece version is a recent addition to the family. The pieces are numbered in order of disassembly, it being a bit easier to explain that way. To disassemble, slide the subassembly of pieces 1, 2, 3, and 9 one block-width to the right. Remove pieces 4 and 5 upward. Next remove pieces 6, 7, and 8. All the other pieces then come easily apart.

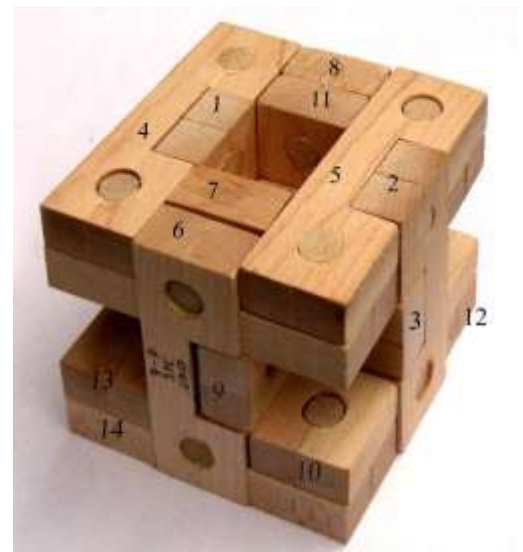
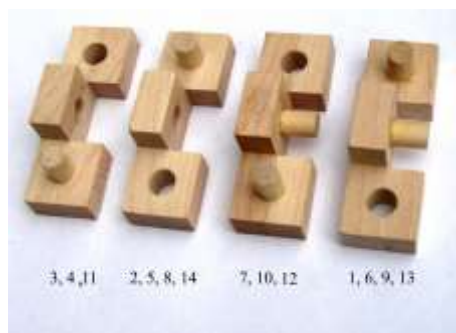

10. Giant Steps. This was another variation of *Square Knot*, made by adding extra blocks to six of the standard *Square Knot* pieces, which did little more than change the assembled shape. I made only a few, which is perhaps just as well.

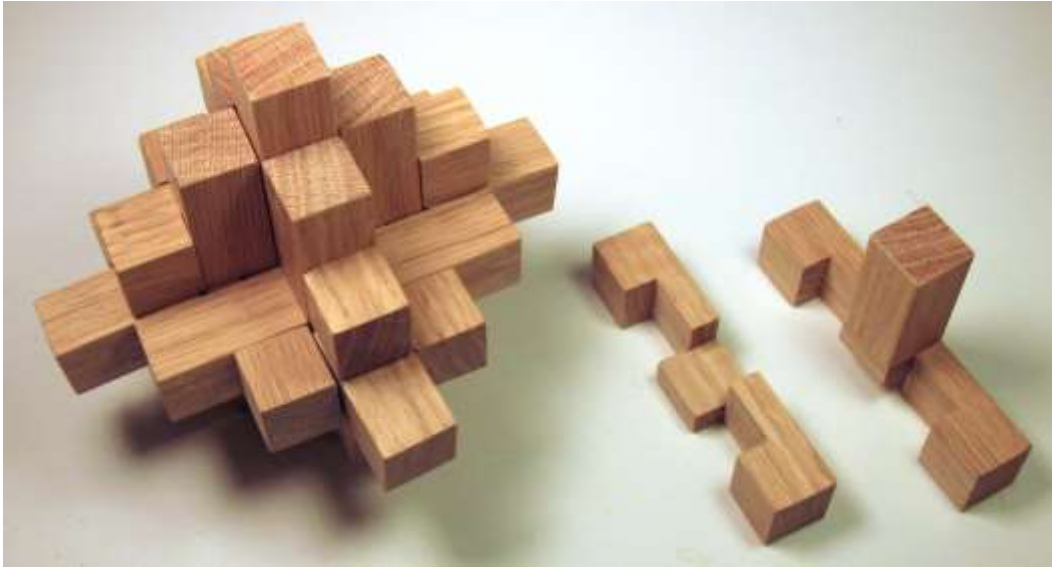

11. Hexagonal Prism. The six dissimilar pieces of *Hexagonal Prism* assemble one way only and with only one axis along which the two halves can slide together or apart, a significant improvement over my previous designs of this general type. Now we're talking about a real puzzle, with sculptural aspects to boot. I often made them of mahogany and rosewood, both stable woods, with a light wood for the center blocks. But this one is in walnut, canarywood, and maple. Subassemble 1+2+3 and mate with 4+5+6.

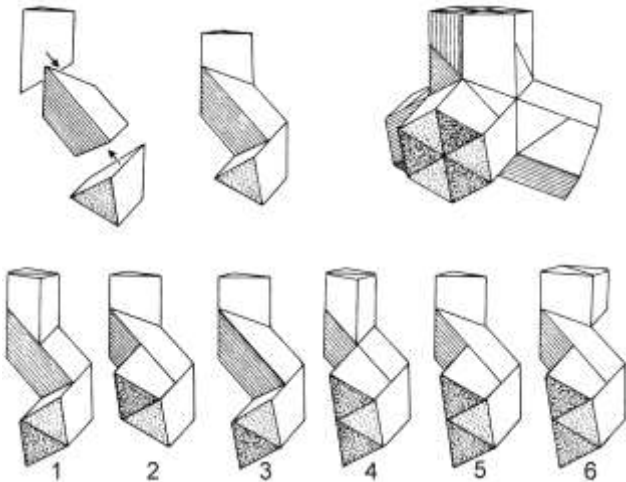

In the early stage of my woodcraft, using a micrometer I measured cubic samples of 22 of my favorite woods in all three directions under both dry and humid conditions, and then graded them by stability. The best was cocobolo, which I stopped using because it caused a bad rash on my face and arms. Next best were teak and padauk, followed closely by Brazilian rosewood and Honduras mahogany. All domestic hardwoods fared poorly in my test.

I was always on the hunt for fancy woods to use, and at shows we woodcrafters often swapped woods with each other or tips on where to find them. But I needed a steady supply in greater quantity. One of my fellow woodcrafters suggested the J. H. Monteath Lumber Company of South Amboy, New Jersey, a major supplier of exotic tropical woods. But when I tried to place an order I was told by head man Doug Dayton: Sorry, wholesale only. So I sent one of my best *Jupiter* puzzles to him as a gift and thereafter had no trouble ordering. Back in the 1970s, Monteath was selling me Brazilian rosewood for \$2.25 per board foot, and other exotics like purpleheart, zebrawood, satinwood, and bubinga for under \$2.00/b.f. in truckload quantities. Yes, those were the days!

11-A. Double Hexagonal Prism. This was an experimental variation made by simply adding more blocks, mostly for sculptural effect. I made at least two of these, and possibly more. Assemble in two groups of three, as usual, 1 2 3 + 4 5 6.

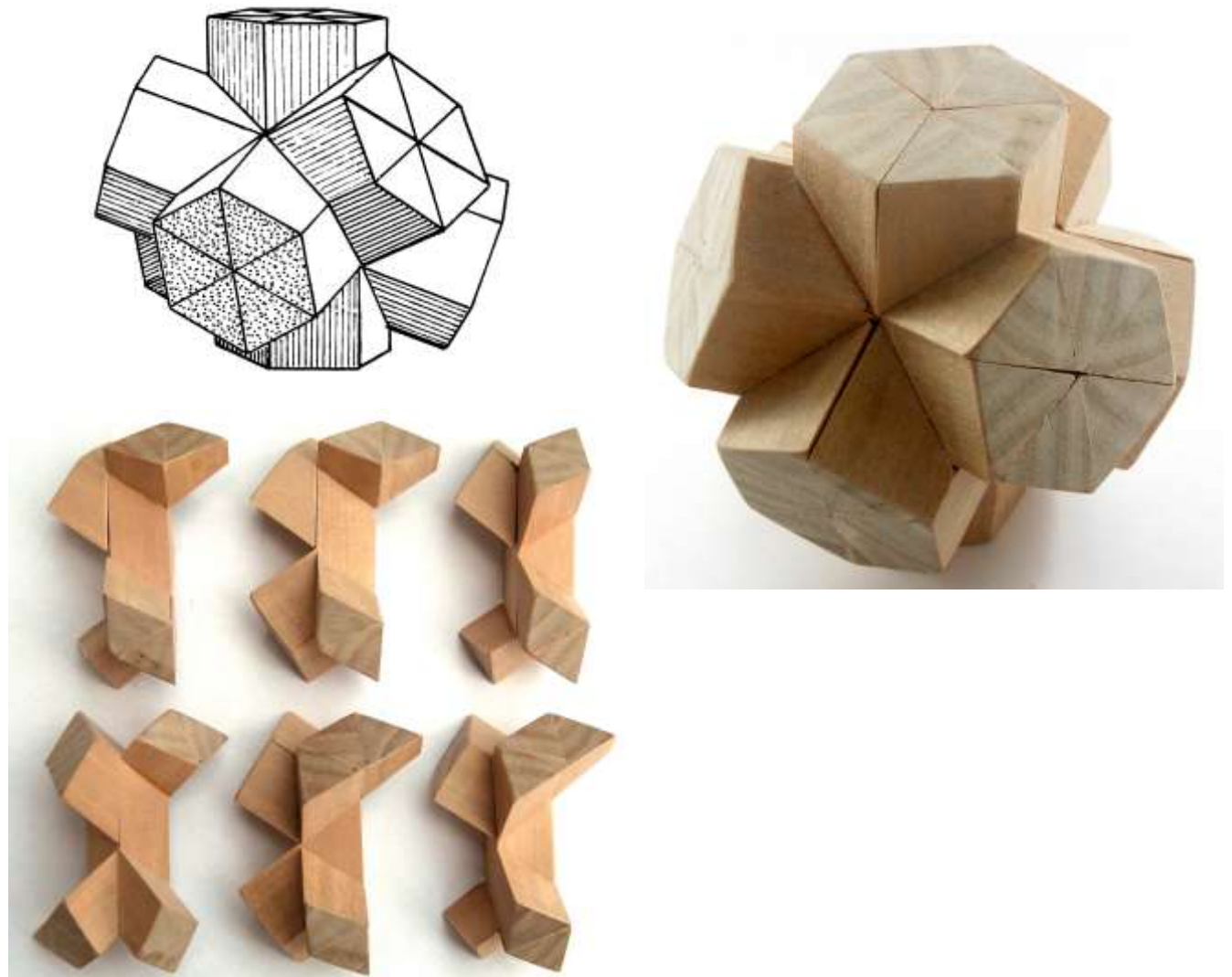

12. Triangular Prism. Many of the intriguing sculptural effects that I achieved were more accidental than deliberate. The elegant *Triangular Prism* is made by simply adding 12 more triangular blocks to the *Hexagonal Prism*. I usually made them in either mahogany or rosewood, both stable woods and easy to work. Later, reproductions well crafted in rosewood were made by Wayne Daniel, Lee Krasnow, and possibly others. An IPP exchange.

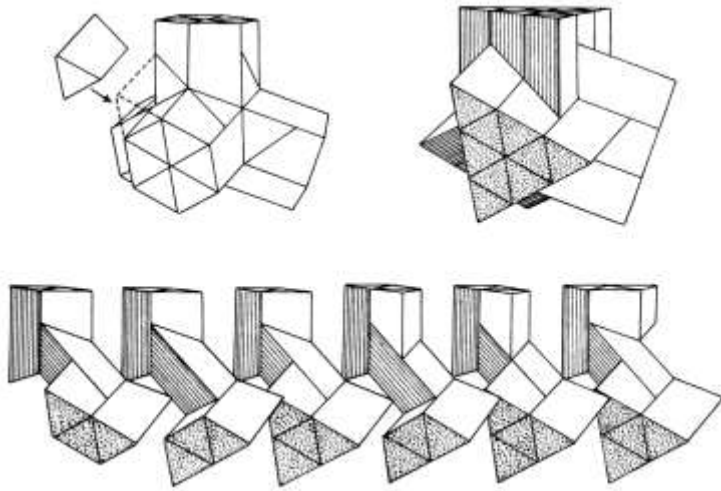

You may have noticed that the pieces shown often do not match the assembled puzzle. The reason is that I am using many photos of the assembled puzzles supplied by Nick Baxter and others, but for showing the pieces I have to scout around to see what I can find, and often end up making them. I don't think it matters. The objects of this *Compendium* are accuracy, clarity, and attractiveness, in that order.

12-A. Triangular Prism, Alternate

Version. This again illustrates how a basic design can lend itself to many variations by simple changes. Here the added blocks are attached by their end faces rather than sides (see drawing for #12). Many other variations are possible.



Almost from the start, I marked my puzzles somewhere in pencil with the serial number, my initials, and the year made. But not always, and sometimes they were hard to see if on a dark wood like rosewood. Or they may have worn off. Their presence or absence is often noted in the auction and seems to affect the value, even though the reproductions made by others often far surpass my own workmanship.

Which of course reminds me of another story. My companion Mary and I spent many enjoyable vacations biking with friends all across Europe. In 2005 we were ending one such trip in Prague. Our friends knew about my puzzle craft from the illustrated T-shirts made by John Rausch that Mary and I sometimes wore. One day they excitedly told us to go look in a certain store window displaying similar puzzles. When we did, we noticed several well crafted reproductions of my designs. Inside the store were many more in a glass case (below), one of which especially drew my attention. I told Mary that it was one I made, and if only we could take it apart I would show her my initials inside. However we could not because the case was locked and the store owner was not there, but only his young helper. It was my *Triangular Prism*, made in mahogany around 1983 and here priced at 5750 cz, which translates to about \$250 and five times my original price. When back home, I consulted puzzle expert Jerry Slocum for an explanation. It seems those other puzzles were made by skilled Czech craftsman Josef Pelikán, whom I had once met at the International Puzzle Party in Chicago. But how my *Triangular Prism* got there remains a mystery.



12-B. Double Triangular Prism. I must have made at least two of the *Double Triangular Prism* because Nick Baxter sent me this photo of one, and here are the pieces of another I recently made in poplar. It is made by starting with the *Triangular Prism* and

simply adding more



triangular blocks for sculptural effect.

13. The General. *Four Star*, of course. It is created by adding yet 12 more blocks in turn to the *Triangular Prism*, really just for sculptural effect. I made most of them in Honduras mahogany, but the accompanying photo is of one I made in a beautiful tropical wood called almond (not to be confused with our native nut tree). As I recall, it has a distinctively pleasant smell. I sometimes found it more reliable to identify woods by smell rather than by appearance. But the pieces here are oak and poplar.

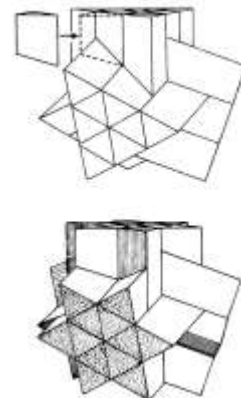
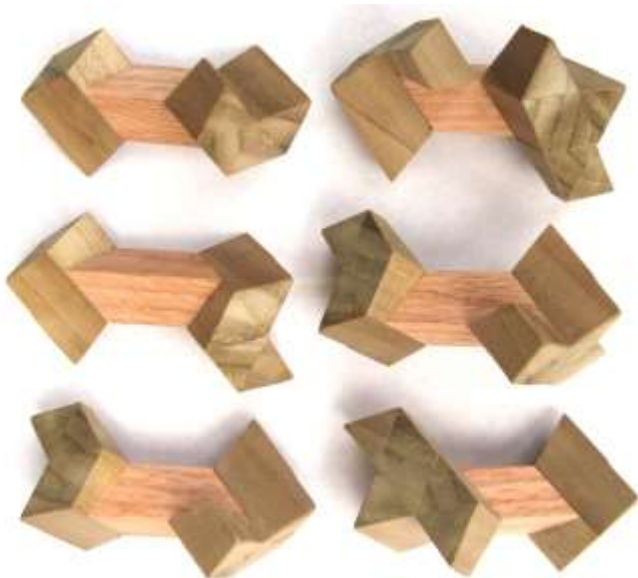

13-A. The General, Alternate Version. Oh well, given the foregoing explanations, just exercise your imagination on this one. I made one around 1974, and Lee Krasnow has made this beautifully crafted reproduction. But the pieces are mine in oak. The arrow on the drawing indicates that the added blocks are attached end-wise in this alternate version, as opposed to side-wise in the standard version.

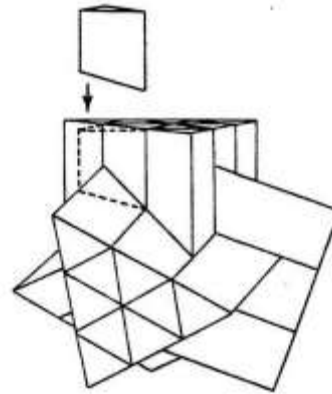
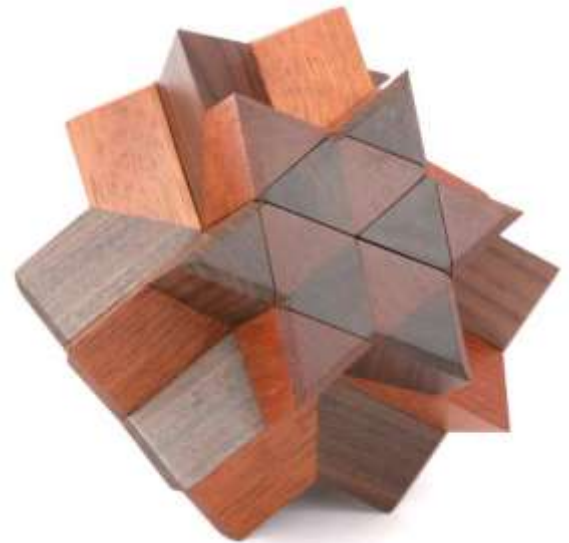

13-B. Ring of Diamonds. This is an improved version of *The General* using rhombic rather than triangular stick segments. Evidently I designed it in 1973, but it was then filed away and forgotten until recently rediscovered. Here in oak.

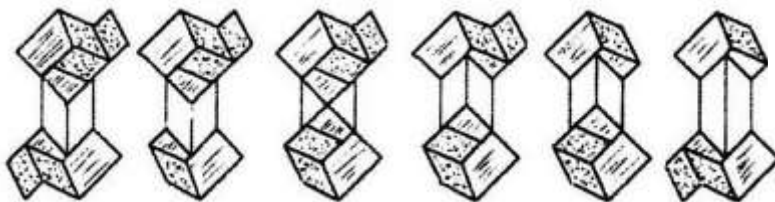
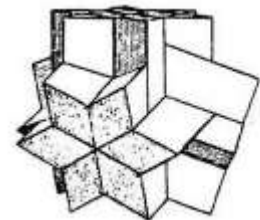

13-C. Eight Star. Of course we had to have at least one of these to round out the set. I may have made only one, and would not have even known of it but for a photo supplied by John Rausch.

But now in 2017 I have made another so we can get at least some clue what the pieces look like.

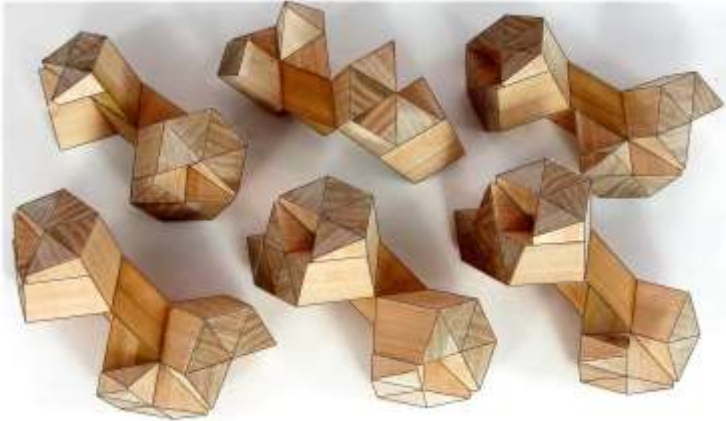

14. Super Nova. It has the same assembled shape as *Nova #8* - the second stellation of the rhombic dodecahedron. With six dissimilar non-symmetrical pieces, now it becomes more of a puzzle. In the drawing, the blocks added to *Four Corners* are shaded. But alas, it inherently has two solutions rather than the preferred just one. This beautiful reproduction is by Scott Peterson.

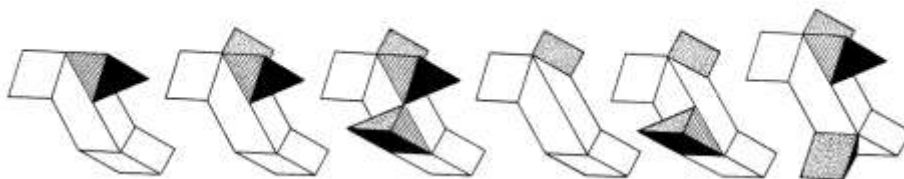
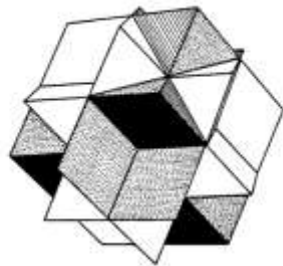
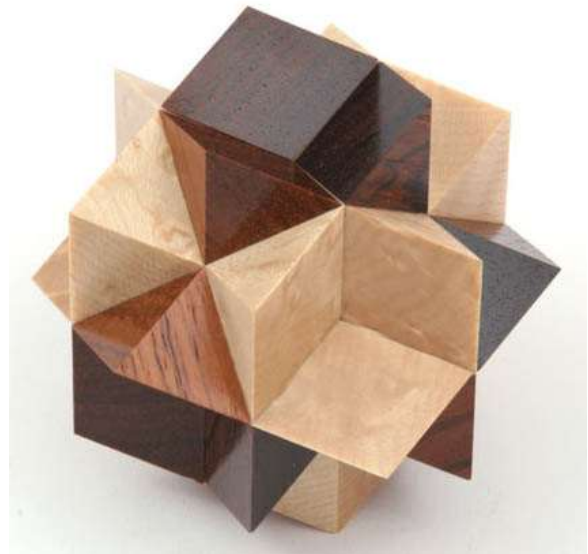

14-A. Second Stellation. This is an improved reissue of *Super Nova*, or actually a pair of reissues, both with the same geometry, but one with end blocks sawn from square stock and the other from triangular, for different appearances. See if you can spot the difference in these two models.



14-B. Augmented Second Stellation. Two different versions are shown here. They are both essentially the *Second Stellation* but with some of the end blocks lengthened by varying amounts. In the first variation, six dissimilar woods are used. In this second variation, the arms of the *Second Stellation* are further lengthened to create yet another interesting polyhedral sculpture.



One of the pleasures of this form of mathematical recreation combined with woodworking is the seemingly endless and sometimes surprising sculptural possibilities that await discovery by the curious experimenter simply by judicious addition of what are, by this stage, standard parts readily at hand. The two shown here illustrate the many interesting variations that are possible.

I started out making most of these various polyhedral puzzles using one-inch square or triangular stock, but around 1975 when it was becoming harder to find fancy woods in one-inch size, I scaled them down to 0.800-inch, and even later to 0.750-inch.

15. Triumph. Wouldn't it be fun to have an interlocking puzzle that could be assembled different ways to form several different geometric shapes? With some effort and perhaps a little confusion, *Triumph* can be assembled into any one of three different polyhedral shapes, all having a three-fold axis of symmetry, as well as into many other nondescript shapes. (We will be seeing the terms three-fold, four-fold, and so on frequently. Simply put, an equilateral triangle has three-fold symmetry, a square has four-fold, and so on.) Furthermore, each piece is made in two contrasting woods such that each mechanical solution has two versions with different color symmetry. By taking a little extra care in sawing out the end blocks, the grain patterns will also be arranged symmetrically.

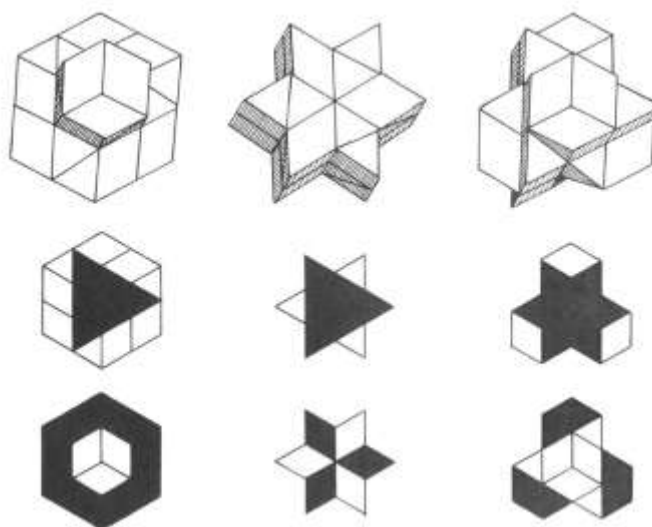
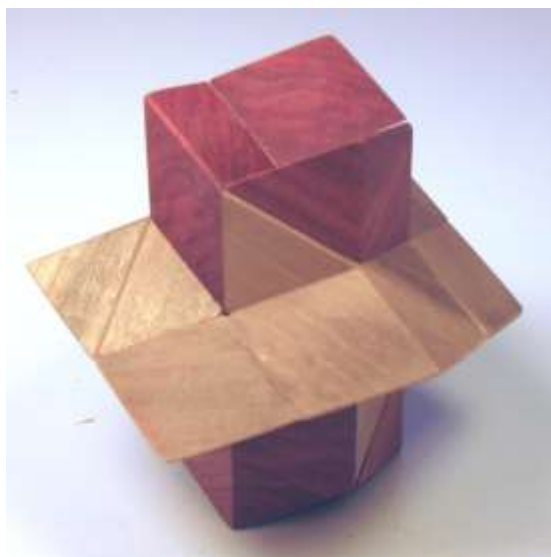

15-A. Fusion-Confusion. Often the most vexing task in this business is to come up with satisfactory names for new puzzle creations. (It probably shows.) In a rare flash of lucky inspiration, I created the *Fusion-Confusion* by joining two pairs of *Triumph* pieces together in a particular way, resulting in only four pieces but ever so much more potential for recreation. For a start, three of the four axes of assembly are eliminated, leaving only one confusing diagonal axis. The object is to assemble into any one of three shapes having a three-fold axis of symmetry (or four solutions if you count mirror images). There are in addition 12 assemblies that produce nondescript shapes. The pieces are usually made of two or three contrasting woods such that each solution will automatically be enhanced by an intriguing pattern of multicolor symmetry. An IPP exchange.

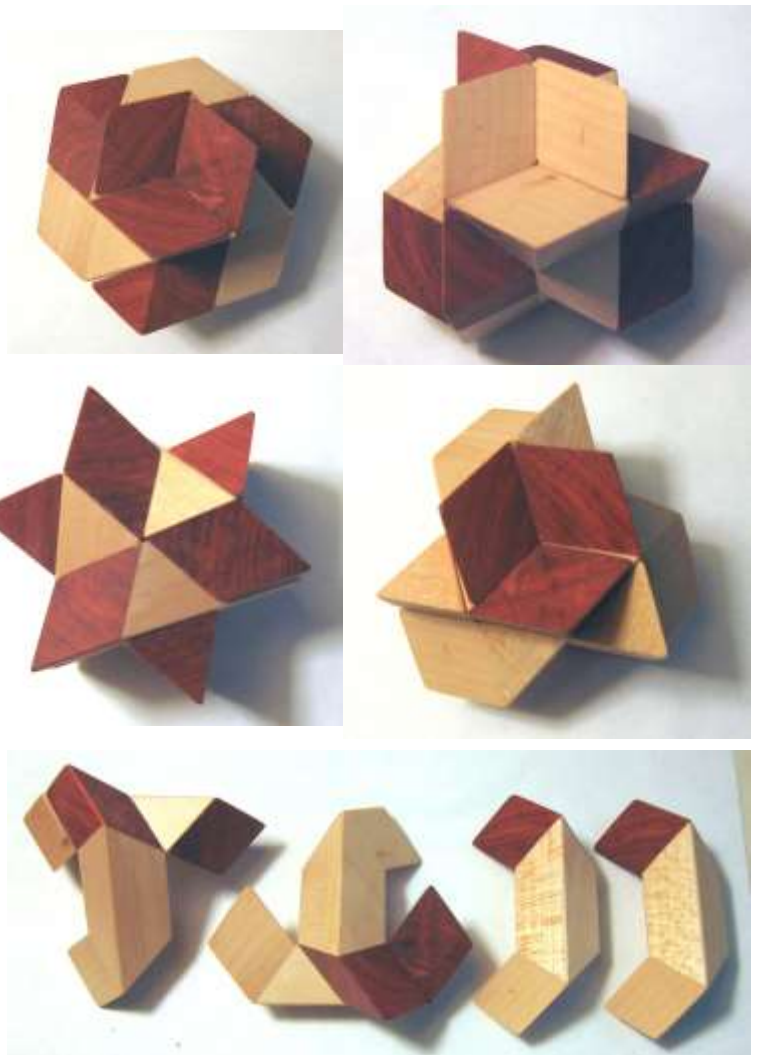

15-B. Triumph Companion. Details on the *Triumph Companion*, if they ever existed, seem to have become lost. Perhaps that makes it all the more fun. It has two kinds of pieces, three of each, in two contrasting woods as shown. My old notes indicate that it has eight symmetrical solutions, but I can find no description of them, so we leave it to the curious reader to fashion a working model and figure them out. I am guessing that the name suggests the possibility of combining it with *Triumph* pieces (as I have just done) to create yet more sculptural possibilities. For a start, shown here are three.

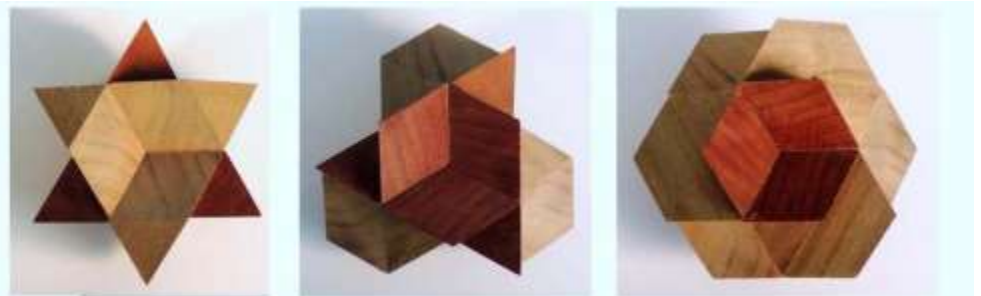

16. Dislocated Scorpius. We 3D puzzle designers talk a lot about symmetry. In recreations of this sort, one naturally assumes that the sought for solutions are symmetrical rather than “random” (whatever that word means), and the most sought for are the most symmetrical. Evidently the human eye seeks symmetry. To probe deeper into the psychology of it, perhaps it is the universal satisfaction of bringing order out of chaos, whether in international affairs, housekeeping, puzzle-solving (or especially book-writing!). That suggests starting with maximum disorder, meaning pieces that are dissimilar and non-symmetrical, and coaxing them unwillingly into a state of maximum order. That theme will continue to be developed as we progress through this *Compendium*.



Dislocated Scorpius has six identical but non-symmetrical pieces, making it more interesting as an assembly puzzle, as well as holding more firmly together. It can be made with four contrasting woods, as shown here, in a way such that the two mechanical solutions produce different symmetrical color patterns. Seen here is what I call the Ring pattern.

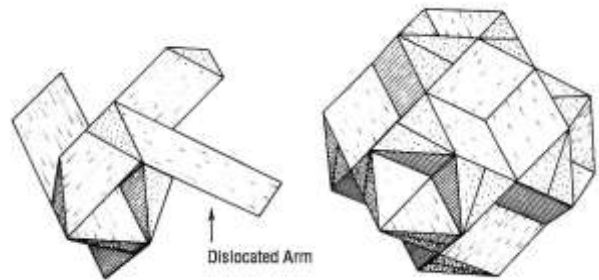

17. Dislocated Jupiter. It of course followed the same path of evolution as the *Dislocated Scorpius*, for pretty much the same reasons. This drawing of one of the 12 identical pieces should suffice to explain the design. It was known to have at least two solutions, but it enjoyed only a short lifespan and was never fully investigated. I made a few around 1975, but in only one kind of wood, so I did not investigate symmetrical color solutions. But in 1987 I made a special one in six contrasting fancy woods, and the problem was to discover the one way to assemble such that all like arms were matched pairs. I wonder where it is now. If it can be found, I will add a photo of it.

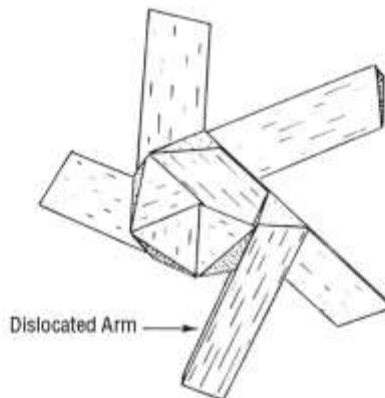

18. Abbie's Waffle. The six pieces of *Abbie's Waffle*, each made of four cubic blocks, assemble various ways onto a square tray or into a 2x3x4 box, as indicated on the instruction sheet. It was created by our daughter Abbie and demonstrated by her on the PBS children's program ZOOM.

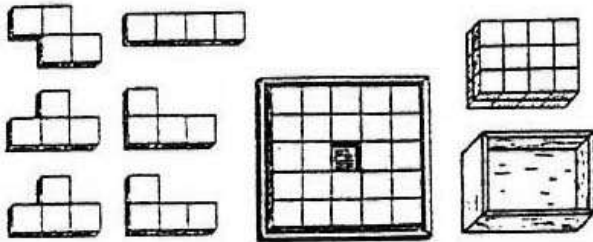

Problems outside the tray

1. Assemble a 4x6 rectangle. Easy, there are 18 ways.
2. Assemble a 3x8 rectangle. Slightly harder, 12 ways.
3. Assemble a 2x3x4 rectangular solid. There are 15 ways.

Problems inside the tray

Shown below are four possible locations for the one empty space, arranged from easy to hard. The number of solutions is indicated for each

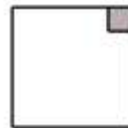

28

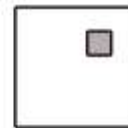

19

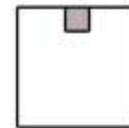

3

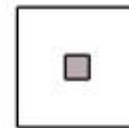

1

18-A. Joined Pairs. The six dissimilar pieces of *Joined Pairs* are made by joining 1x1x2 blocks all possible ways. They pack into a 2x3x4 box seven ways. I wouldn't be surprised if this had been discovered independently by others, which of course applies as well to several other designs shown in this *Compendium*.



19. Pyracube. This introduces a large family of puzzles made by joining polyhedral blocks together different ways, in this case using edge-beveled cubes (or to put it another way truncated rhombic dodecahedrons). Strange as it may seem, they pack snugly and neatly into the cubic box *with or without* the single block. They will also form several other symmetrical assemblies, only a few of which are shown. Use your imagination.



14-BLOCK CUBE



13-BLOCK CUBE



SQUARE PYRAMID



RECTANGULAR PYRAMID



RECTANGULAR PILE



20. Pin-Hole. The basic *Pin-Hole* consists of three elbow pieces, two cross pieces, one plain bar, and one key pin. It assembles essentially one way only but easily into a shape sometimes referred to as a “burr.”

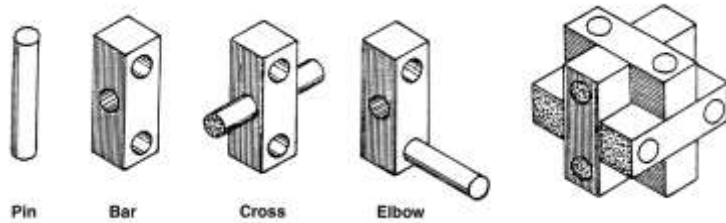

With more pieces and some twice as long, several more complicated constructions are possible. Think of it, then, as an entertaining construction set with the added amusement of puzzling possibilities.

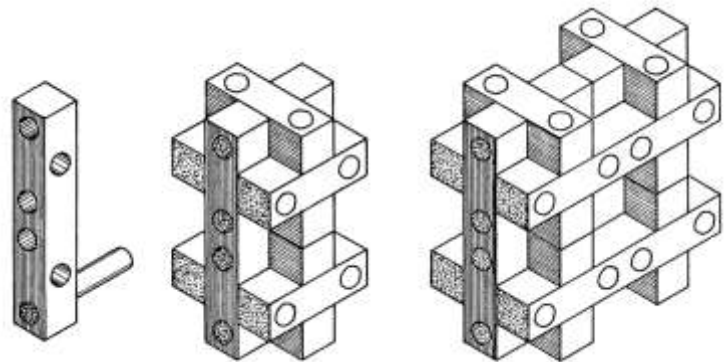

Here is what I call the *Grand Cross* version of the *Pin-Hole*. It uses the standard pieces as shown, and requires the use of two key pins to assemble.



20-A. Grand Cross Variation. This interesting variation uses a quite different set of pieces, with six longer pieces and two key pins, and with all but two of the end holes being blind.

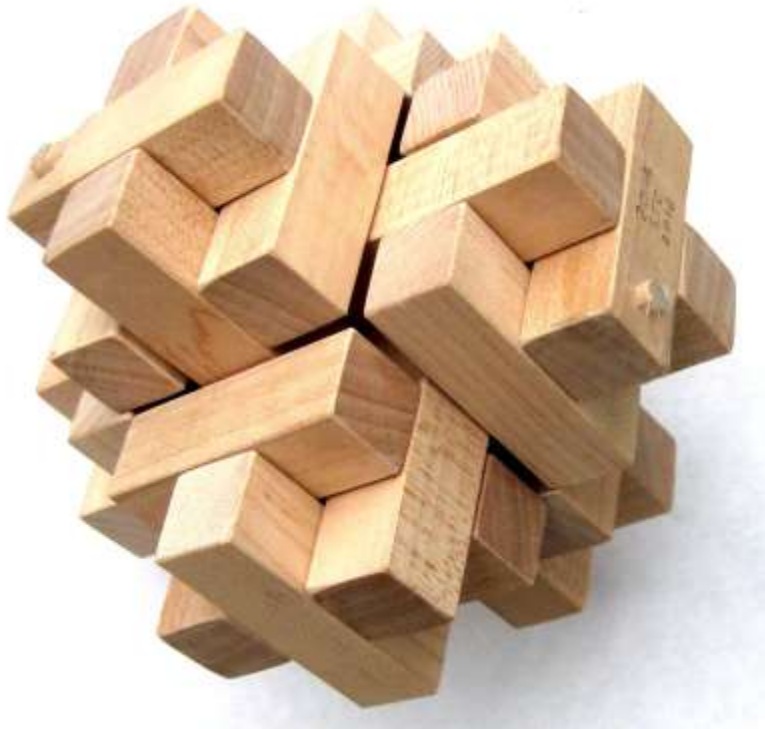
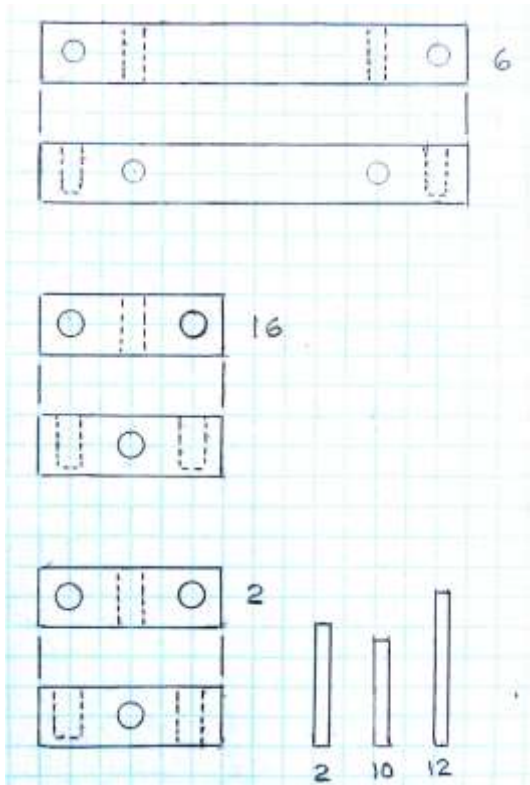

20-C. Playpin. This is a variation of the *Pin-Hole*, #20. It likewise has only one solution and essentially one order of assembly. The principal difference from *Pin-Hole* is that all but two of the end holes are blind. Although not shown in the photo, the two cross pieces are dissimilar because one of them has one end hole drilled completely through. One of the three elbow pieces also has one end hole drilled completely through, also not shown.



For a playful variation of 20-C, change the hole shown above (top) into a blind hole.



20-D. Long & Short. The pins come in two lengths – long and short. For the two cross pieces, the long pin is on the left, short on the right. Elbow pieces 4 and 6 have long pins, while piece 5 has a short pin. All center holes go all the way through, but all end holes are blind. Those marked with a green dot are shallow; those with a red dot are deep. There are two solutions.

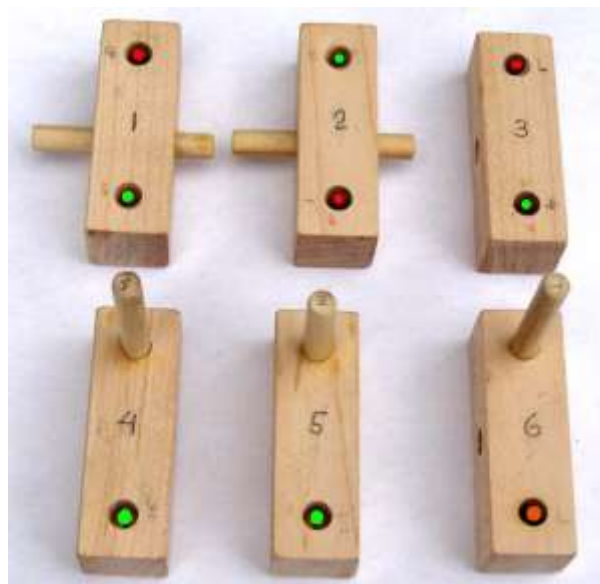

21. Cuckoo Nest. It may not look much like the *Pin-Hole*, but looks can be deceiving. We puzzle designers tend to work from basic mechanical and geometric principles, not appearance. The result may end up looking quite attractive, but that is usually an incidental consequence and not the driving force. Often sculptural effects can be further enhanced by judicious attention to final details. Here we have six hexagonal bars and six pins, with five pairs joined together to form compound pieces, two of which are identical, plus one plain bar and one key pin. There are unavoidably two solutions.



Pin-Hole and *Cuckoo Nest* are both described as having a key pin. Did you notice that being my first mention of the word “key.” Many persons assume that an interlocking puzzle must have a key piece, and in some of the other puzzles described thus far (with many more to come), they will poke around in vain looking for it. I have nothing against keys. Perhaps it would be nice if more of my polyhedral designs had one, but the geometry does not easily lend itself to that form. There will be more later on.

22. Locked Nest. Some of the 12 hexagonal bars and 12 pins of *Locked Nest* are joined together to form elbow pieces. I first made them with five elbow pieces, but a later improved version has six and requires coordinate motion to assemble. Most were of birch, but this one is in oak and maple. Later a few were made in fancier woods. See also #266 for assembly.



22-B. Locked Nest Pile. The name and photo are probably sufficient to tell the story. Given enough parts and patience, the basic lattice structure can be extended indefinitely in any direction. The name is perhaps misleading, as there are no elbow pieces, but rather just 18 bars and 18 pins. It is fairly easy to assemble by following the illustration. There are 12 bars with 5 holes, 3 bars with 6 holes, and 3 bars with 8 holes. The lengths of the pins are corresponding. I have made three. If only I had the time and patience to explore more of the many possibilities here by expanding on multiple axes. Perhaps someone else will.

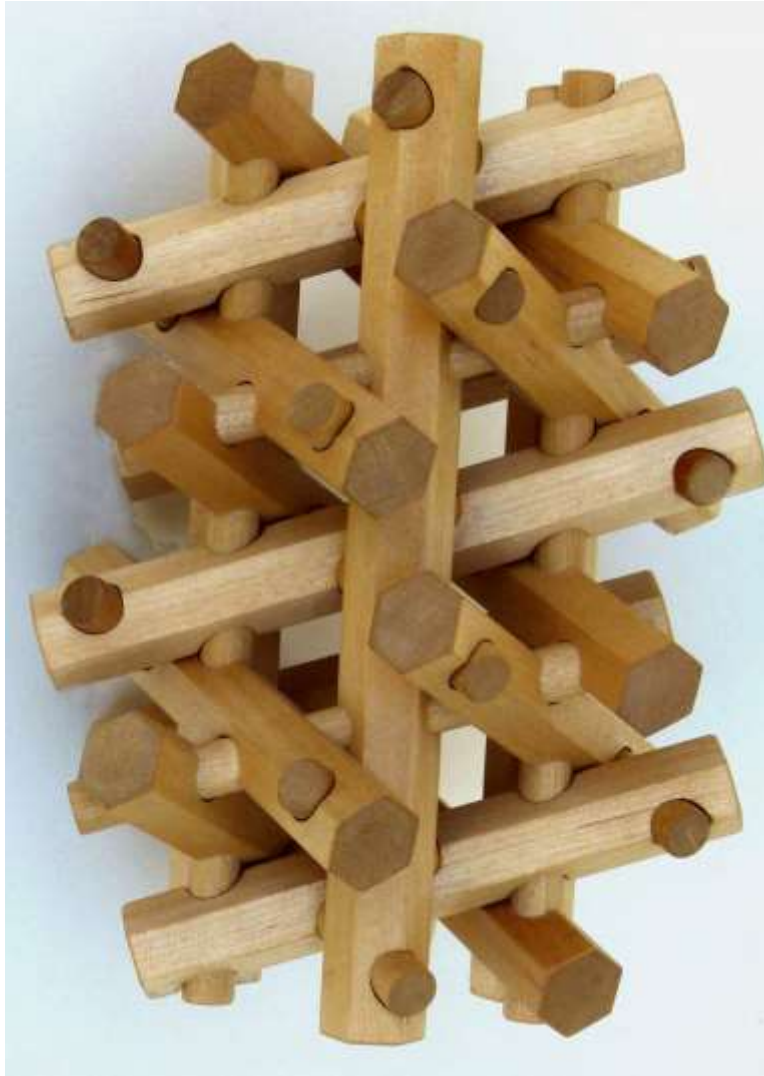

23. Scrambled Scorpius. The aspiring puzzle designer striving for perfection may impose ever stricter rules on what passes for satisfactory as his work progresses. At the same time, Nature is even stricter on what she makes possible within those rules. As a result, for every design included in this collection, maybe a dozen or more were tried and discarded. With enough persistence, every so often one gets just plain lucky, as certainly was the case here. Starting with the basic *Scorpius* #5, we join four arms together in every possible non-symmetrical combination. (See page 85 for analogous *Garnet* pieces.) Would six such pieces even assemble at all? Yes indeed, and with the bonus of a unique and challenging solution having only one sliding axis and essentially only one order of assembly. Surely my lucky day! (Actually one of many.) I made them mostly in mahogany, such as this one, but also a few choice ones lovingly crafted in Brazilian rosewood with double-doweled joints. Fine reproductions have been made by Bart Buie and others. We got a lot of mileage out of this design. (See also Part 5)

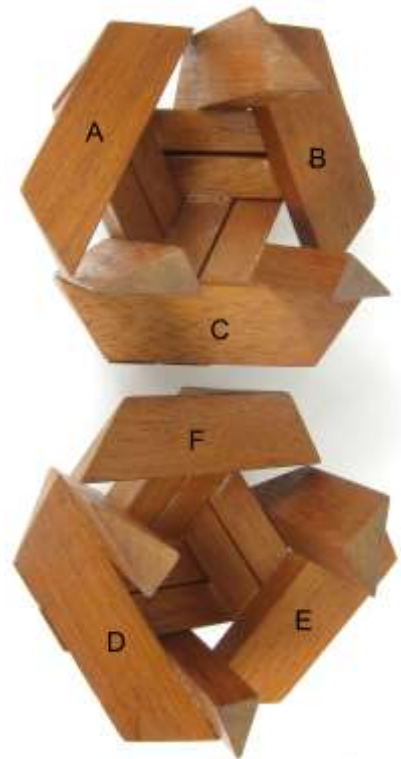
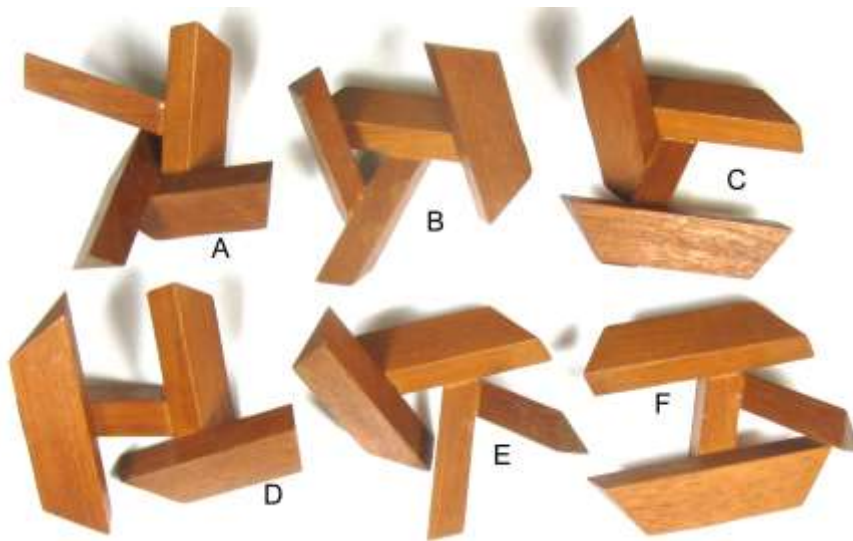

23-A. Egyptian. This is a larger version of *Scrambled Scorpius* made with sticks of trapezoidal cross-section rather than triangular. My friend Mary wanted one that she could assemble easily to demonstrate to her friends, hence the special markings on the inside showing the otherwise difficult solution. First, I chose an eight-letter name with all different letters. Then to assemble, just match pairs of letters: E-G, Y-P, T-I, A-N. I made 22 of them in red oak. I later made a multi-wood version issued as #157.



24. Saturn. Following the success of *Scrambled Scorpius*, it was inevitable to try for a scrambled *Jupiter* to join the family. *Saturn*, with its six dissimilar non-symmetrical pairs of pieces, was supposed to have only one solution, and so it was assumed for a while. But then a determined solver, Stan Isaacs, found at least one other. I had been making them of just one wood, the one shown here being made of andiroba. But after Stan's discovery I made a few in multiple woods, to be assembled with color symmetry, thus eliminating the multiple solutions. It has proven to be not nearly as popular as the *Scrambled Scorpius*. Too complicated, and too difficult for most to assemble without directions. Think of it, then, as an attractive polyhedral (stellated triacontahedron) sculpture that comes apart.

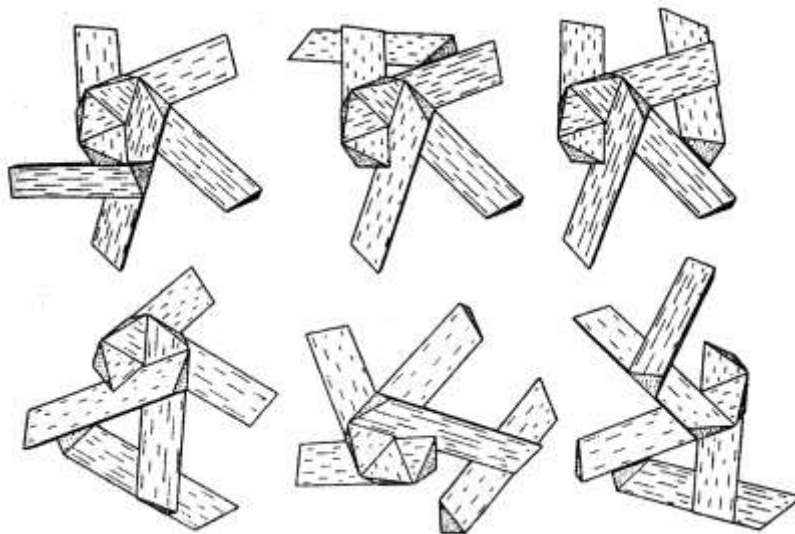

25-A. Hexsticks. My original of *Hectix* #25, which served as the prototype for the manufactured plastic version, has already been described in Part 2. It has nine so-called standard pieces plus three with an extra notch that is essential to permit assembly. So now it finally reappears in wood. *Hexsticks* is the name I use for the wooden version, which differs slightly from the plastic version. It has the usual three pieces with an extra notch, but unlike *Hectix* it has only seven so-called standard pieces and two pieces with only one notch. It has the same three solutions. I milled many of them from $\frac{3}{4}$ -inch birch hexagonal stock.

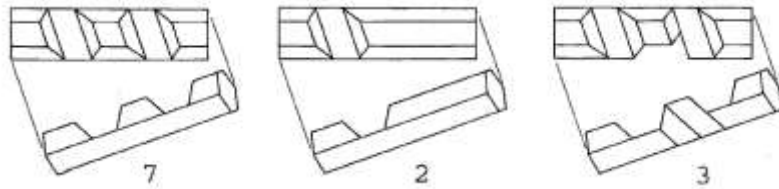

25-B. Giant Hexsticks. It was just that, with the same innards as *Hectix* but double sized. Close inspection of the photo (left) may reveal that the notches were made by gluing up trapezoidal $\frac{3}{4}$ -inch stock rather than by milling them out from hexagonal stock.

25-C. Four-Color Hexsticks. Finally, a *Hexsticks* in four colors, as originally intended. I believe I made only four, and like *Giant Hexsticks*, double-sized and glued up as can perhaps be detected in the photo (right).



Note my switch to the past tense here and elsewhere. Perhaps the meaning is obvious. These were odd or experimental designs, usually made in limited quantity (often only one), and not likely to be reproduced.

26. Four-Piece Pyramid. In general, for geometric puzzles of this sort, the fewer pieces to achieve the objective, the more satisfactory the design. So far, we have seen many designs using six pieces. Five would be better, and four better still. *Four-Piece Pyramid* is a tetrahedral pile of 20 rhombic dodecahedron blocks joined in fives to form four dissimilar non-symmetrical pieces that assemble with some difficulty one way only. Better still, the solution is serially interlocking, meaning that there is only one possible order of assembly. If I may say so, I can see no further improvement possible with this particular pile of blocks. Like climbing a mountain, when you've reached the top you can go no higher. The *Four-Piece Pyramid* is shown here made in limba, sometimes called blond mahogany. The pieces shown are for the alternate version, next page, using edge-beveled cubes, here made of Honduras mahogany.

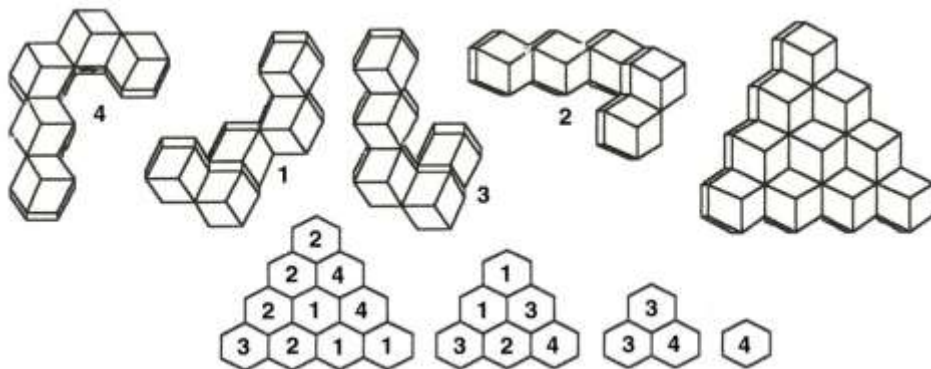

Four-Piece Pyramid is one of my more satisfactory designs, but harder than some to make well (and strong). I produced several different versions in different woods and different sizes. In addition to those made with rhombic dodecahedron blocks (previous page) others used edge-beveled cubes with varying amount of bevel (left), and some with multiple woods (right). Also shown is an experimental version (bottom) in which the four faces are sanded down to create a pattern of ten triangles on each face.



Expansion and contraction with changes of humidity can be a problem with puzzles of this sort. The most stable woods are often dense and oily, hence difficult to glue. For those, a laborious step is inserting dowels to strengthen the glue joints, especially with the truncated version, which has smaller gluing surfaces. With common hardwoods like cherry, the trick is to have the grain of all blocks aligned, thus practically eliminating the effects of humidity.

27. Three Pairs. This is my first so-called coordinate motion puzzle to be listed, and perhaps the best of the lot. With two kinds of pieces, three of each, it looks so simple. But surprisingly, to sub-assemble each of the two mating halves requires careful simultaneous manipulation of three pieces. Even the name misleads! Hence the introduction here of a new term in puzzledom – *coordinate motion*. Some I made of Brazilian rosewood with doweled joints (top). Others also made in cherry (bottom).

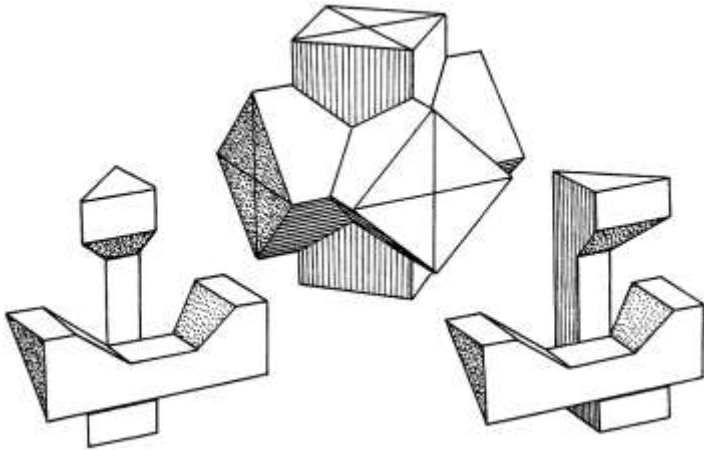

27-A. Three Pairs Variation. Several variations of *Three Pairs* are possible, including this one having the same shape as *Nova #8*. The reproduction shown here was finely crafted in peroba rosa by Interlocking Puzzles. One half is shown in pieces; the other half together. An IPP exchange. To maintain this rose color, peroba must be kept away from UV light.



28. Truncated Octahedra. The five pieces of *Truncated Octahedra* are made of 14 cubic blocks with their eight corners sawn off just enough to create regular hexagonal faces and thus space-filling solids. Joined together different ways, they pack snugly into a square-bottom box. The 12-page booklet that came with this puzzle shows 18 other entertaining problems, such as constructing a square pyramid that fits snugly onto the bottom of the inverted box. For those who like to experiment, the bottom drawing shows the various ways that two or three blocks can be joined. Those used in #28 are starred.

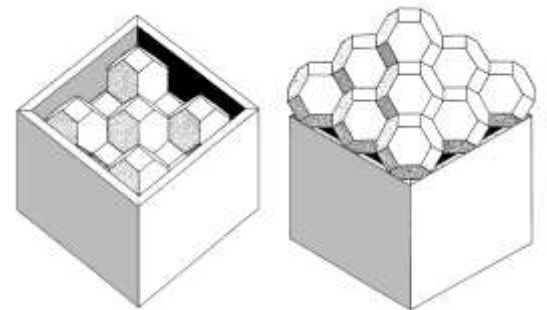
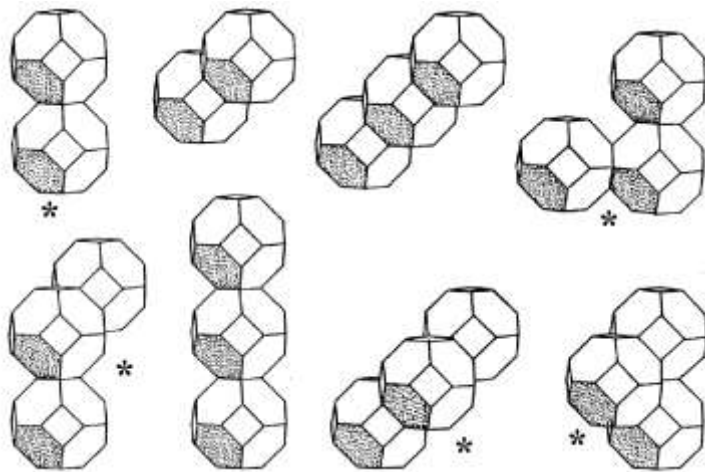

29. Half-Hour. As the reader can probably tell, I sometimes run out of names faster than ideas. Some solve this easy looking puzzle quickly and are apt to question the name, but others take a lot longer and question it for the opposite reason. The simple fitting together of puzzle pieces made of cubic blocks joined together different ways has enjoyed a universal appeal all down through the ages. I well remember the first such puzzle that I made. It was a six-piece dissection of the $3 \times 3 \times 3$ cube shown in *Mathematical Snapshots* and known as *Mikusiński's Cube* after its Polish mathematician inventor. In my teens I crudely fashioned one of scrap lumber to satisfy my curiosity of the stated two solutions. Thirty years later I decided to seek an improved design with the same features but only one solution. Result: the *Half-Hour* puzzle.

For a $3 \times 3 \times 3$ cubic dissection, there is an optimum number of pieces. If one were to plot a graph of difficulty vs. number of pieces, it would start out at zero with one solid cube, ascend into a playful arc, and return back to near zero with 27 cubic blocks. Here the optimum number of pieces is six. One would prefer that they all be dissimilar and non-symmetrical, and of course with only one solution. But not all that is possible so one must accept compromise. The *Half-Hour* puzzle is my best effort. It has only one solution. It was the culmination of quite an exhaustive investigation into the near countless number of possible designs. Hans Havermann and David Barge sent me hundreds of possible constructions with these pieces, just a few of which are shown. I seem to have lost those many others, but you can invent more of your own.

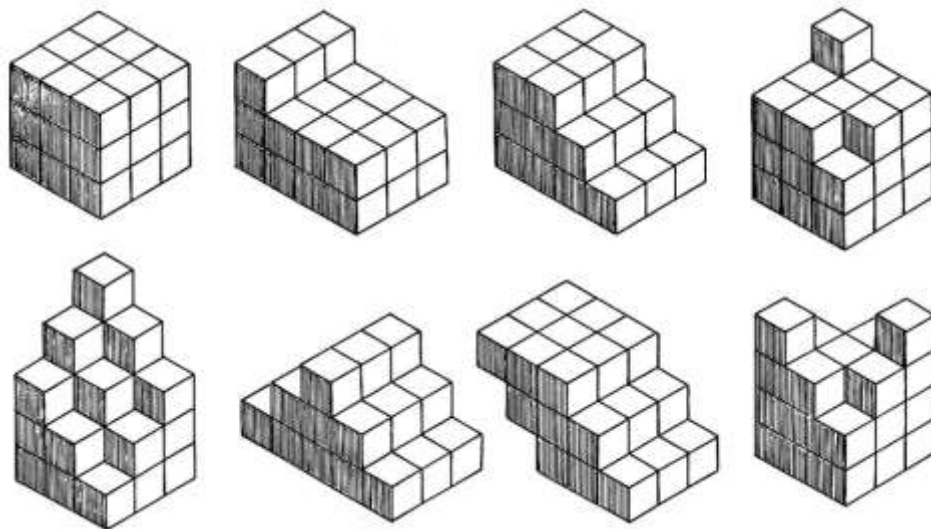

30. Convolution. Throughout the short recorded history of puzzle designing, cubic dissections have enjoyed much popularity, especially of the 4x4x4 cube. Indeed, the very first 3D puzzle that I designed and made was one such. When I was employed at MIT Lincoln Laboratory, we had an informal puzzle club organized by puzzle guru Gus O'Brien. I was prompted to fashion a frankly uninspired seven-piece dissection of the 4x4x4 cube. I saved it for sentimental reasons, but eventually I sold it to a now deceased keen puzzle collector in England for its presumed historical value.

In 1979 I decided to have another try. The result was this seven-piece *Convolution*, with its symmetrical grain pattern on all six faces. An added feature is its serially interlocking solution surprisingly involving rotation. This one is in oak and tulipwood. Nicely crafted reproductions have been made by other woodworkers.

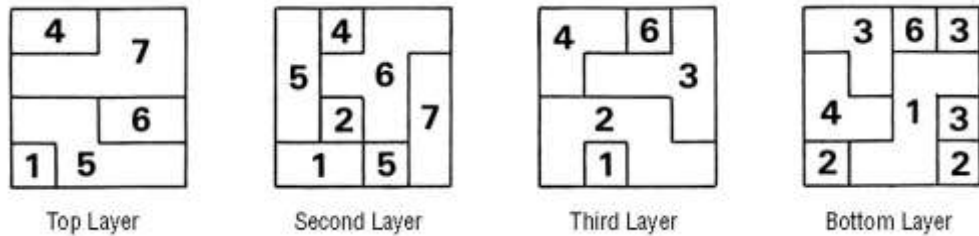

I show the design details here, but with some reservations because there is so much more recreational potential for the reader in exploring for clever new combinations rather than simply copying mine or someone else's. Satisfactory wooden cubes readily available in hobby stores can easily be glued together for experimenting.

31. Octahedral Cluster. We puzzle designers sometimes make the mistake of creating puzzles so fiendishly difficult that few if any will solve them. Generally they are easy to design merely by increasing the number of pieces. But what is the point? More appealing are puzzles with few pieces that look so simple, but ah.... *Octahedral Cluster* has four dissimilar non-symmetrical pieces, made by joining 19 rhombic dodecahedron blocks (top) or edge-beveled cubes (bottom) together different ways. Its one tricky and unique solution is serially interlocking. I suspect that this particular octahedral dissection having all of these features may be in itself unique.

I made a few *Octahedral Clusters* of Spanish cedar, and of course there is a story to go with that wood. In 1979 I learned through the woodcraft grapevine that the Stanley Smith knife handle factory in Roscoe, New York, was being liquidated because of a big fire and because the new NY 17 highway was going right through it, and that Stanley had a large collection of rare woods he had collected over his many years and was willing to get rid of. So I hastened out there to buy some. I hesitate to use the word “buy” because he practically gave it away, but only to craftsmen whose work he approved of. Fortunately that included me. I was so fascinated by Stanley that on my third and last visit, Jane and I spent an evening with him and his wife in their living room beautifully paneled with woods from around the world, and I took notes of our conversation. It turned into quite a long and fascinating story that I have recorded elsewhere. But as for that Spanish cedar, Stanley said he bought an entire monastery in Santo Domingo so he could tear it down and salvage the Spanish cedar, which he then used for closet linings. When he passed away in 1983 at age 89, each of his three children inherited a collection of some of my best crafts made with his exotic woods.

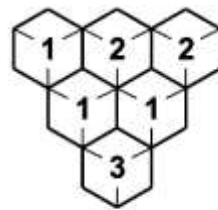

Top layer

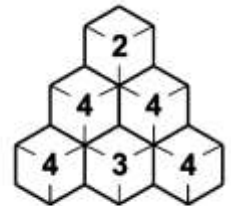
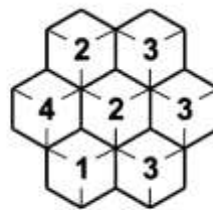

Bottom layer

Assemble in order numbered.

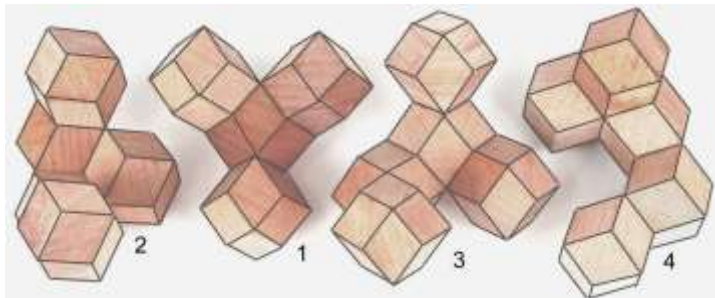

31-A. Five-Piece Octahedral Cluster. This version is if anything even more perplexing than the four-piece version. Shown here made of edge-beveled cubes. The key fifth piece is a single block. The one design flaw is that piece 3 is symmetrical. I made a few of these in camphorwood, and of course there must be a story that comes with that wood too. The old Irving & Casson furniture company of Boston, founded in 1875, was liquidated in 1974. One of the partners was said to have traveled all over the world collecting rare woods, some of which then ended up in the hands of wealthy industrialist Peter Boshco. He donated some of it to the Old Schwamb Mill in Arlington, Massachusetts, noted for their ancient but still operating special lathes for turning elliptical picture frames, and more recently turned into a craft center. The Mill then sold some of the lumber, and I was the lucky buyer of a few boards of camphorwood. Peter happened to be there at the time, and he told me with much emphasis that it came from “mainland China,” so I could only assume that it was something special. Peter had more rare woods stored at his home in West Medford that he offered to sell me, but before I could get there he had passed away.

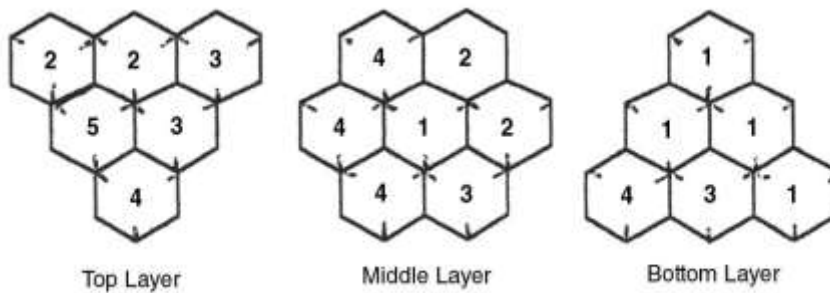

32. Broken Sticks. The six dissimilar non-symmetrical pieces of *Broken Sticks* assemble one way only, and with only one sliding axis along which the two halves can separate. The significance of the name is that all of the 12 sticks appear continuous, yet half of them are “broken” internally into two halves. It has only the one difficult solution. The twelve added blocks that create the six dissimilar pieces are shown shaded in the drawing. I usually made them in Honduras mahogany, as seen here.

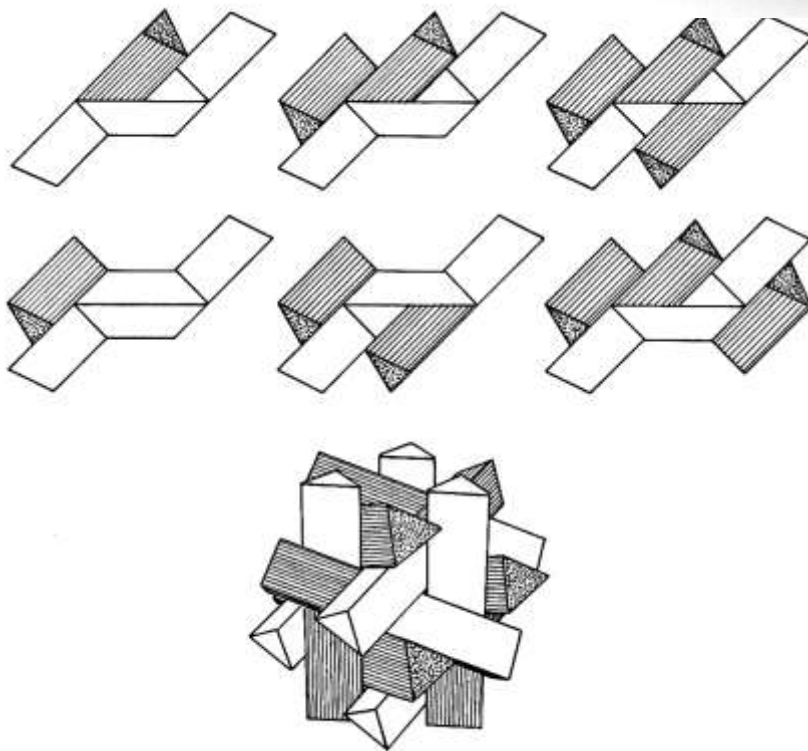
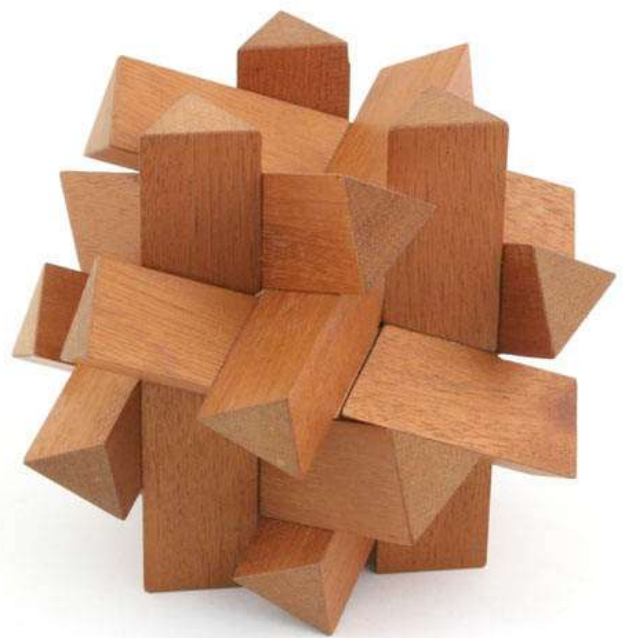

33. Twelve Point. The six dissimilar non-symmetrical pieces of *Twelve Point* assemble one way only and along only one sliding axis to form an intriguing solid intermediate between the second and third stellations of the rhombic dodecahedron. I usually made them in two contrasting woods. This one is made of cherry for the main body and Gaboon ebony for the points, since that way uses this precious wood sparingly. The neat solution, as well as attractive geometry, has prompted several other woodcrafters to fashion reproductions.

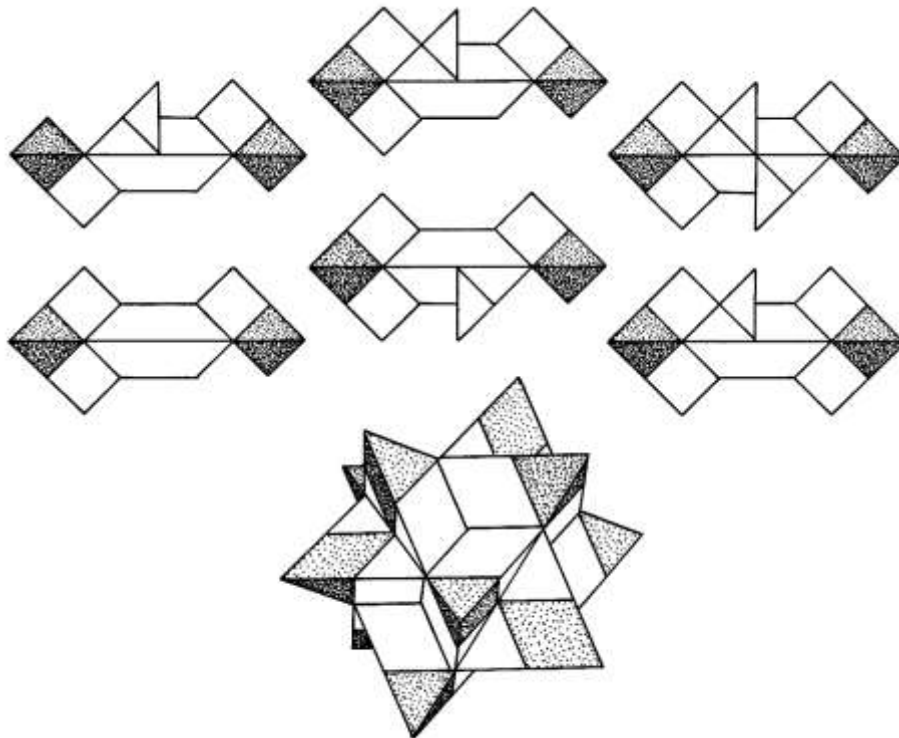

34. Augmented Four Corners. By now, the pattern should be familiar. To convert *Four Corners* #6 from a polyhedral sculpture into more of an assembly puzzle, blocks are added to the corners to create six dissimilar pieces with only one solution and one sliding axis. The added blocks are shown shaded. I usually used two or three contrasting woods. This one is in cherry and Brazilian rosewood.

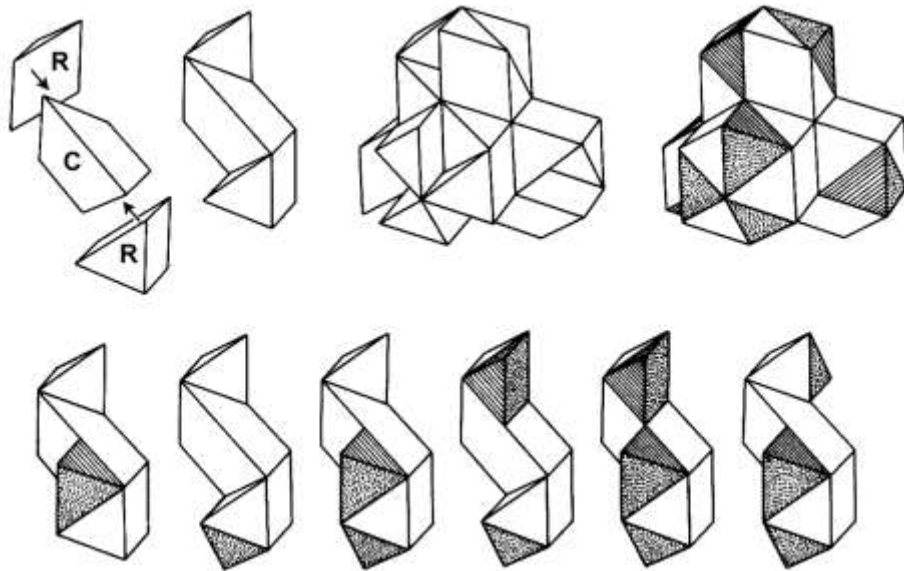
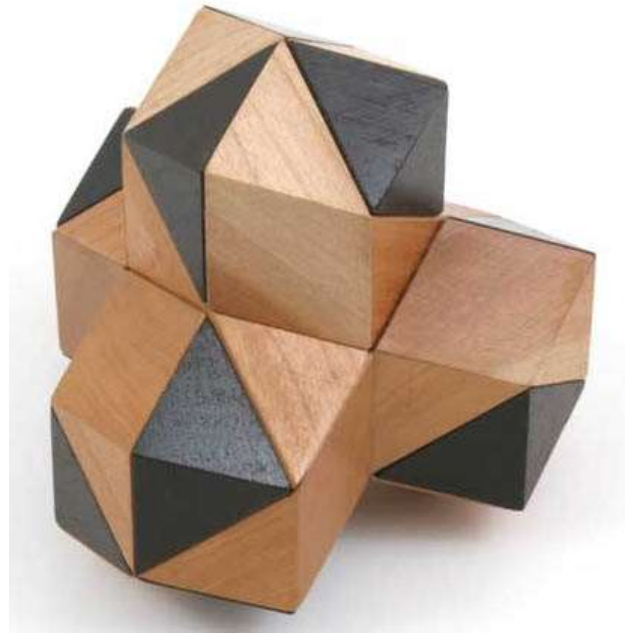

34-A. Augmented Four Corners, Reduced. By judiciously sanding down the four “faces” of *Augmented Four Corners*, interesting new sculptural effects can be created. In the first example shown here, three bi-colored triangles appear on each of the four faces. In the next, the shape has been further reduced to tetrahedral, with colorful patterns on each of the four faces. I probably made only one or two experimental models of each version



More recently I made this experimental matched pair of *Augmented Four Corners*, normal and reduced, of padauk-mahogany-maple to be photographed for this edition of the *Compendium*.

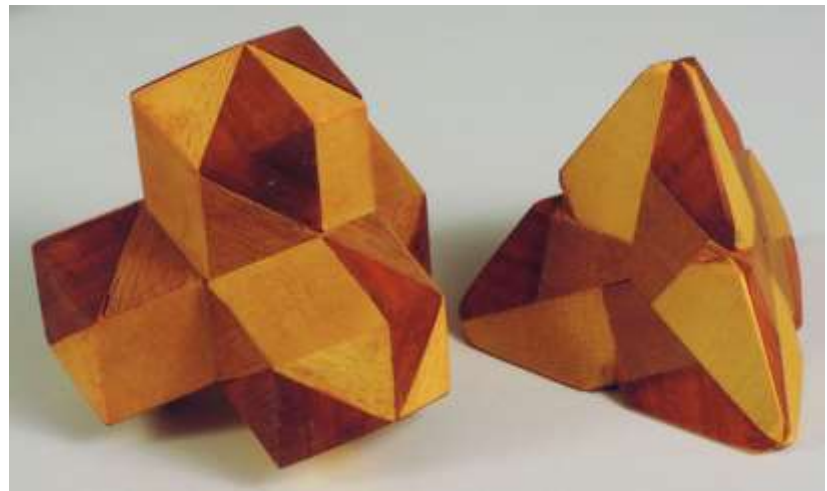

Compiling this *Compendium* has produces many surprises. From John Rausch comes this photo of an *Augmented Four Corners* modified by reduction to have a cubic envelope. I have no record or recollection of having made it.



35. Burr #305. And now at long last we come to the most familiar by far of all 3D puzzles, and probably the oldest too, the venerable six-piece burr. This is actually a very large family that all look alike assembled but have different arrangements of notches inside. Bill Cutler determined by computer there are over 30 billion possible combinations with standard (integral) notching. Most have empty spaces inside. Considering only those with no internal voids, there are *only* 119,979. Further limiting this to using only pieces that can be milled out with standard woodworking tools brings the number down to 314. Next, we eliminate all those with identical or symmetrical pieces and those with more than one solution. Now we are down to 18. I have further weeded this list down to the only two that come apart by the less common separation into two halves, and those are my “chosen ones.” One of those, *Burr #305*, is illustrated here. This one is made of one-inch bubinga, a tough wood to work but worth the extra effort.

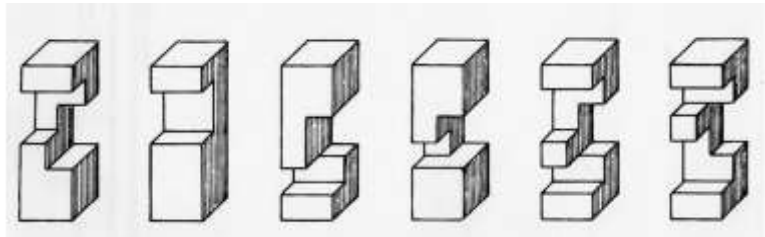

36. Coffin’s Improved Burr. The name is misleading. This was one of my early attempts in 1981 to design a six-piece burr that does not go together or come apart directly, but instead requires multiple shifts to do so. In my distribution of it, I challenged other puzzle designers to improve upon it, which they certainly have done. Some of them are using computers, and again Bill Cutler has shown the way. In the flurry of activity that followed, many designs emerged much better than mine. So I include this attempt more for its historical significance, for this is presumably what got the ball rolling.

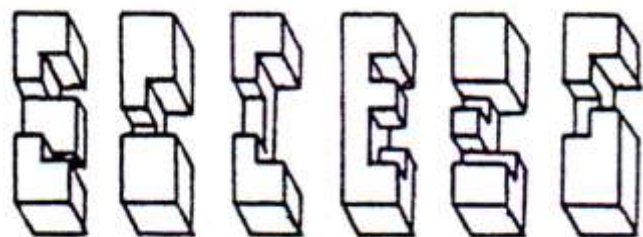
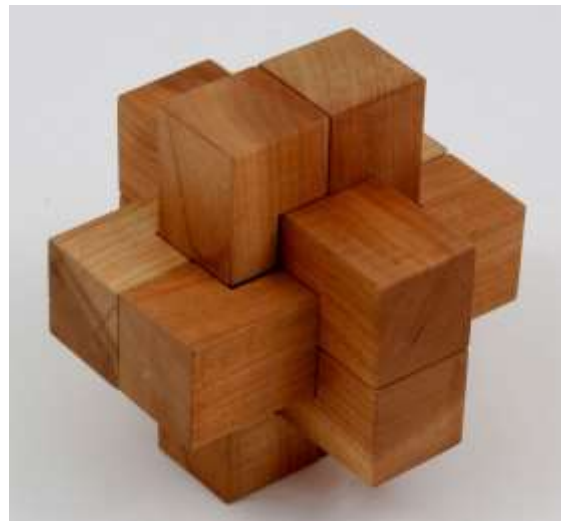

37. Star of David. It has six non-symmetrical pieces that assemble three different ways, some with a surprising diagonal axis of assembly, to form three different symmetrical polyhedral solids. Because of the difficulty of solutions, which might prevent some puzzlers from enjoying the aesthetic appeal, unlike most of my puzzles it came with explicit assembly instructions. This model is in mahogany. It has been beautifully reproduced by other craftsmen.

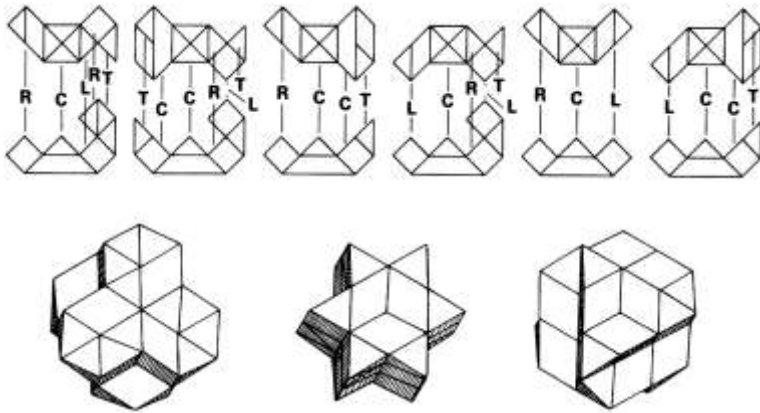

37-A. Star of David Improved. This version has simpler pieces, which is the reason for listing it as improved. This model is in bloodwood and cherry.

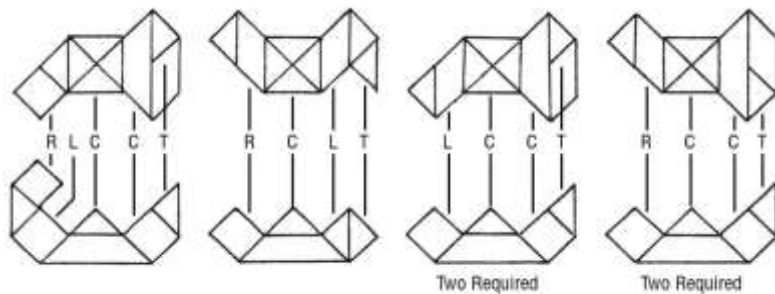

38. Three-Piece Block. I dashed off the design of this simple puzzle in response to a request from a New York advertising agency, whose client, Citibank, wanted hundreds of them for use in some sort of sales promotion scheme. The base of it presumably resembles Citibank's corporate logo. I also made some for general sales. What a surprise it was when friends started reporting it was one of their favorite puzzles, much more confusing than I had at first assumed. You never know. The designer of a puzzle may not always be the best judge of its difficulty, since he or she does not usually have the opportunity of trying to solve it. *Three-Piece Block* has been reproduced by other craftsmen. Several minor variations are possible. Honduras mahogany.

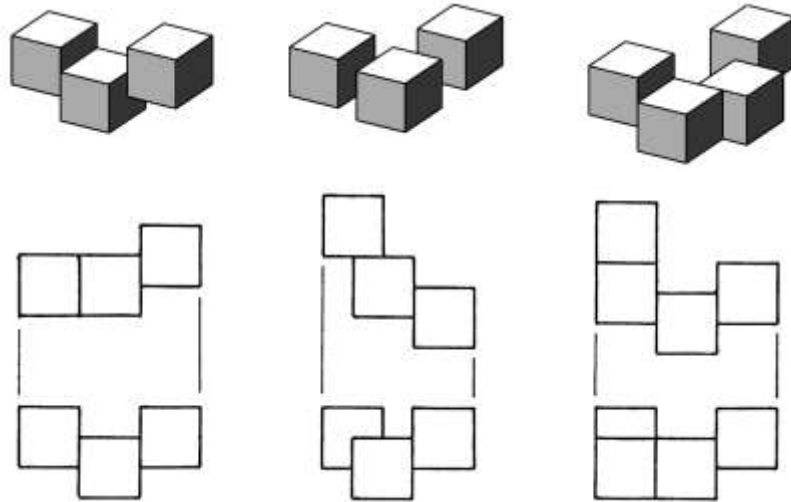
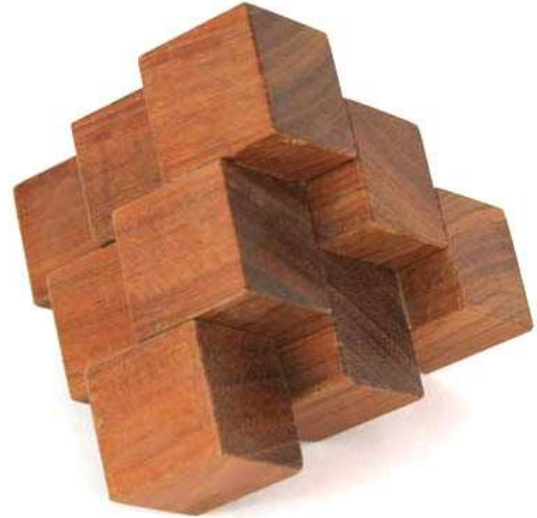

39. Rosebud. This is my second coordinate motion puzzle, the first being *Three Pairs* #27. But this time all six pieces must be engaged simultaneously. It is very difficult to do without some aids such as tape or rubber bands, although it has been done. To make it somewhat easier, I did offer an assembly jig #39-A to hold all six pieces in perfect alignment, so that even the masses could enjoy the fascination of watching the colorful “petals” open and close like a flower blossom. It has been very well received in the puzzle world and reproduced by others. That small removable peg shown in the photo is a stop that allows one to play with the opening and closing feature without it flying hopelessly apart. The second photo shows it partially opened. The model shown is rosewood and tulipwood.

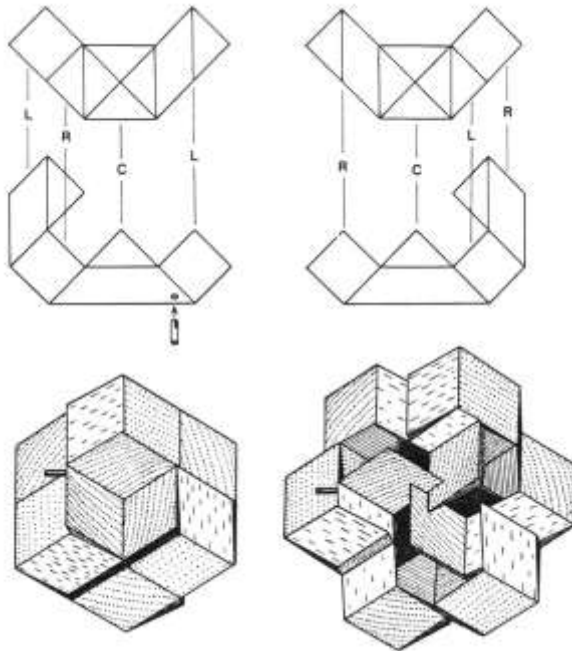

39-A. Rosebud Assembly Jig.



40. Interrupted Slide. This was another of my attempts to design a clever six-piece burr that did not come directly apart but instead required multiple shifts. I include this one with reservations, because others such as burr expert Bill Cutler have designed better ones. Photo is one I have recycled.

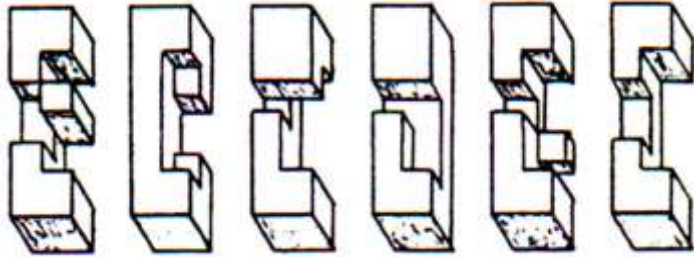

41. Unhappy Childhood. It consisted of 10 checkered pieces, each made of five cubic blocks joined different ways, that packed checkered into a 5x5x2 box one way only. Credit for the computer analysis that led to this surprising unique design goes to Mike Beeler. Without the checkering, there are 2408 solutions. The name, by the way, came from a sarcastic comment I once received at a craft show, and we can skip the details. You see, I was always seeking names for puzzles and used this one in desperation.

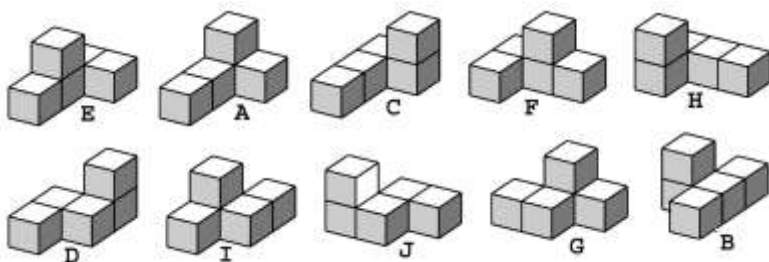
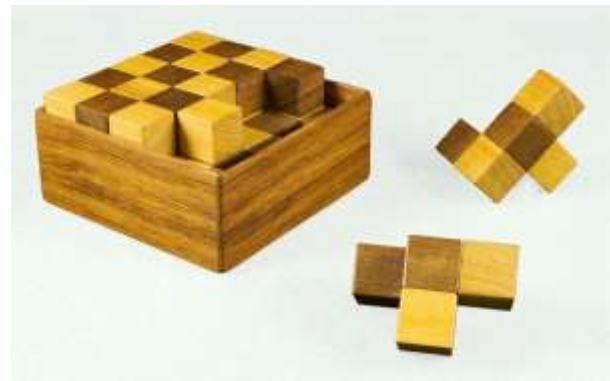

F		H		J
	E		I	
		A		
	G		B	
		D		C

TOP LAYER

	H		J	
F				I
	E		A	
G				B
	D		C	

BOTTOM LAYER



42. Seven Woods. As you may have figured out from the name, seven different kinds of wood go into the fabrication of the simple *Seven Woods*, six of which are seen when assembled. It is supposed to be assembled with matching ends of pieces, and it makes a nice way to display fancy woods. For fun, it can be expanded in all directions almost to the point of collapse. This beautiful reproduction is by Lee Krasnow.

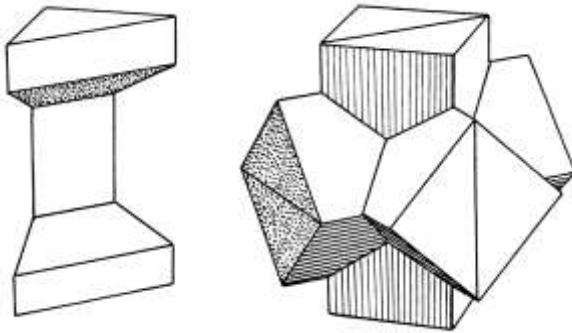

42-A. Brickyard. This was a variation of *Seven Woods*, distorted by compression along one two-fold axis, so four of the six “faces” are rhombic rather than square. I probably found figuring out all the angles of the saw cuts entertaining, but beyond that, now 20 years later, I am unable to explain what might have been the purpose of all this. In the model shown, each of the six pieces is glued up from three distorted six-sided center blocks (see Appendix), and then the six faces have been squared off. The purpose of the schematic diagram is simply to illustrate this particular type of distortion, which has here been exaggerated for clarity. I believe I made only this one, which is perhaps just as well.

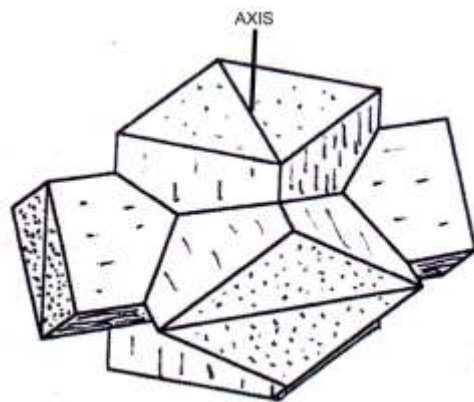

43-45. Topological Puzzles.

My order of serial numbering results in an ever-changing mixture of styles, whereas my previous book on mathematical recreations, *Geometric Puzzle Design*, followed a logical order of development. I hope this random order makes for a more interesting format. After all, that has been not only the actual path of development but also pretty much the story of my life.

So, to digress from geometric designs for a moment, in an effort to come up with a product that anyone at craft shows could afford, we started a line of easy-to-make topological puzzles. The most popular of these was the familiar old novelty, presumably the inspiration of famous puzzle inventor Sam Loyd, that we called our *Buttonhole Puzzle* #45. We made them from scraps of exotic woods and sold them for 25 cents each. Our girls would loop one around someone's buttonhole and then challenge them to remove it. We were told that some of them remained still attached years later.



Another of our topological puzzles was *Sleeper-Stopper* #43, which was my variation of a familiar old puzzle. The object was to move the rosewood bead from the dark side (purpleheart) to the light side (satinwood) or vice versa. *Super Sleeper-Stopper* #44 had an extra hole for added confusion.



Since we could not find any really nice wooden beads, I invented a sanding machine with eight-inch rotating disk to turn them out, first by the dozens, and later with a larger 14-inch machine by the hundreds. It worked so well that for a while during summer vacation, my kids were helping turn out fancy beads by the thousands for sale at craft shows, starting at 20 cents each. Later we added buttons, earrings, and pendants to the line, all crafted of colorful woods highly polished. Shown here are a few samples. It was fun while it lasted, but by summer's end I was glad to resume the crafting of puzzles.



The Odyssey of the Figure Eight Puzzle

But before returning to geometric designs, we must include this bizarre tale of the legendary *Figure Eight Puzzle*. The raw materials for creating interesting topological puzzles can be nothing more than a length of wire, pliers for bending it, and a loop of cord. I was idly playing around with just such one day and came up with this simple design.



I then wondered if it were possible to remove the loop of cord. I finally became convinced that it was not, but a formal proof was beyond me. Just for fun, I included it in the 1985 edition of a book of sorts I once produced called *Puzzle Craft*, without indicating whether or not it was solvable. My purposely vague description left some readers with the impression that it must be solvable, but they were utterly baffled as to how.

Then Royce Lowe of Juneau, Alaska, decided to add my *Figure Eight* to the line of puzzles that he made and sold. When some of his customers started begging for the solution, he came to me for help in vain.

It next appeared in a British magazine on puzzles and games. The puzzle editor made the mistake of stating that it was topologically equivalent to the *Double-Treble-Clef Puzzle* (right) made by Pentangle and therefore must be solvable. But careful inspection will show that they are not equivalent.



To add even more to the confusion, my humble little *Figure Eight Puzzle* appeared in *Creative Puzzles of the World* by van Delft and Botermans (1978), with hopelessly complicated directions for solving, which was their idea of a prank. Then someone from Japan sent me a seven-page impossibility proof that I couldn't fathom. A scholarly sounding proof also appeared in the April 2006 *American Mathematical Monthly*.

When it comes to puzzles, it is often the simplest thing that proves to have the greatest appeal, probably not even suspected at the start. Whoever would have guessed that this little bent scrap of electrical wire and loop of string would launch itself on an odyssey that would carry it to the far corners of the world? I wonder if this will be the final chapter in the life of the infamous *Figure Eight Puzzle*, or will it mischievously rise again disguised in another form, as topological puzzles so often do?

46. Vega. This one is easy to assemble by mating two mirror-image halves of three pieces each, and is more a fancy wood sculpture rather than a bona fide puzzle. I always made it in two contrasting woods. The small dark blocks added to the ends did not require much wood, so it was a good way to display expensive or rare woods in short supply. The six pieces are identical and symmetrical. The geometric shape could be described as intermediate between the second and third stellations of the rhombic dodecahedron. This well crafted reproduction is by Bart Buie.

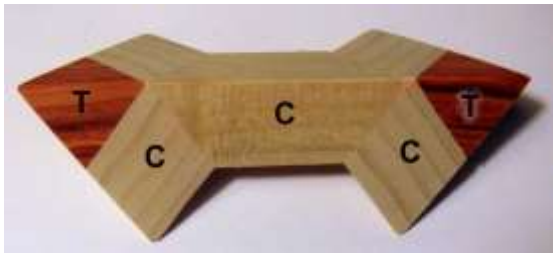

Sample piece is in poplar and padauk.

Here is another gem, this one by John DeVost in (I'm guessing) rosewood and yellowheart.

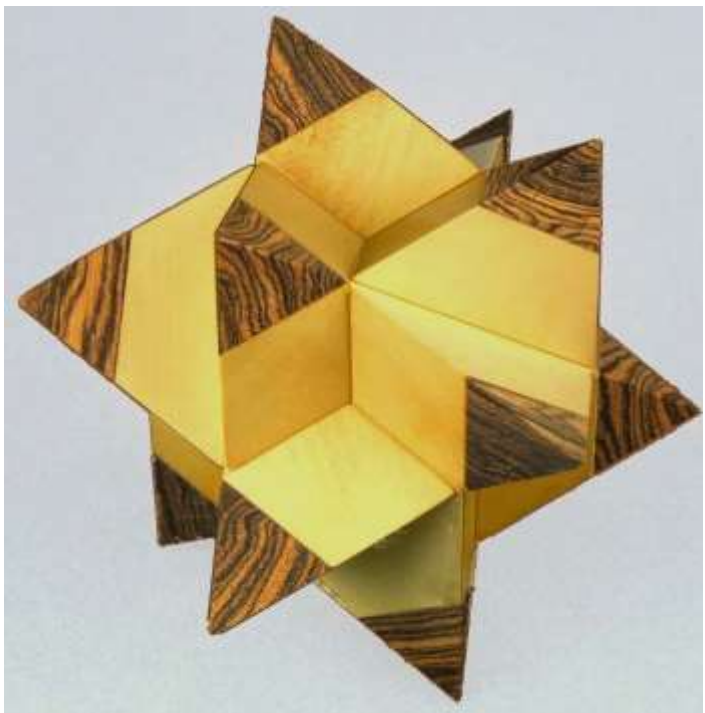

47. Cluster-Buster. This one follows what is by now the familiar scheme of judiciously adding parts to the six-piece diagonal burr. All six pieces are identical in shape. They are glued up from standard AP-ART building blocks (see Appendix). In some reproductions, six dissimilar fancy woods have been used to add to its pleasing sculptural geometry. As suggested by the name, it may be more difficult to disassemble than to assemble, as two or three fingers of each hand must be placed in just the right places to push the two halves apart. This one made in canarywood by Lee Krasnow. It has also been made in what I refer to as the truncated version (below).

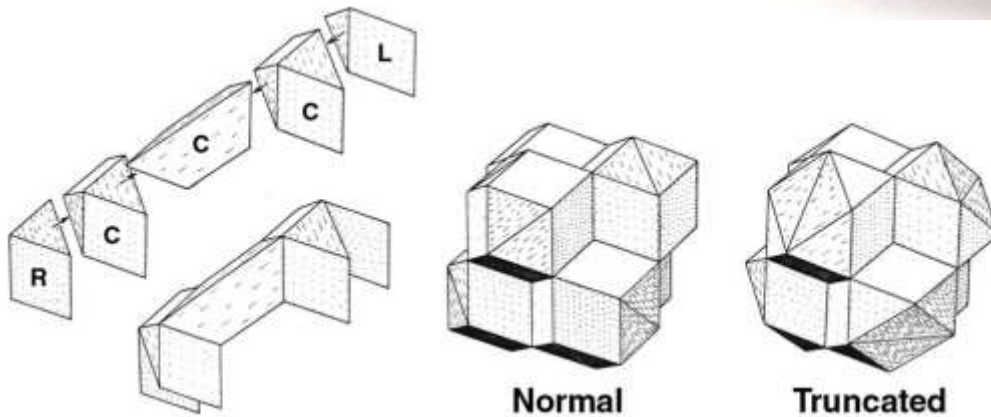
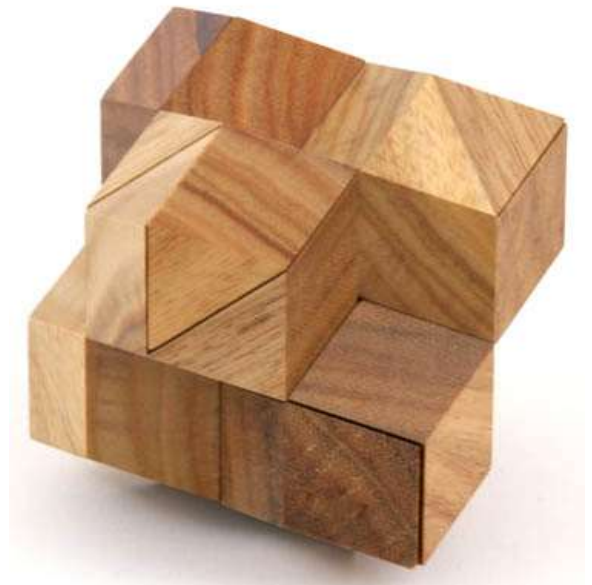

48. Truncated Cluster-Buster. This variation is made by starting with the standard version of *Cluster-Buster* and then squaring off the six sides. This well crafted reproduction in three exotic woods is also by Lee Krasnow.

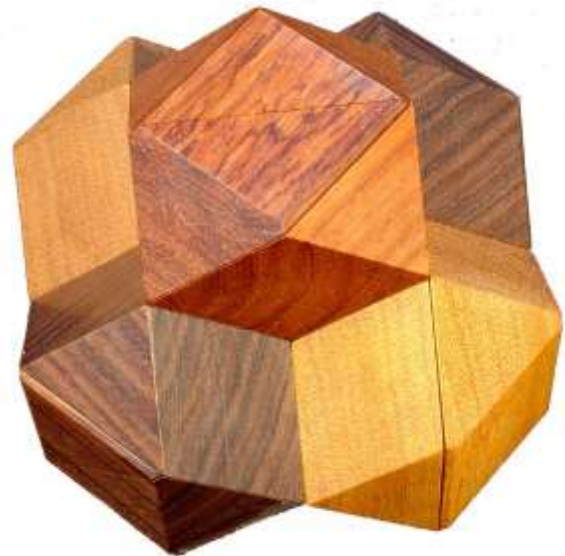

49. Improved Cluster-Buster. The amusing story of the *Improved Cluster-Buster* is that I made 10 of them in 1973 but evidently failed to record the design. However, in the 2003 *Compendium*, John Rausch shows my drawing for the three pairs of pieces, and also two photos. Also shown - an assembled one made by Tom Lensch and a disassembled one made by Lee Krasnow. In addition, John has sent to me this photo of one made by me in 1973. From all that I have tried to reconstruct the three pairs of pieces, two of each required. I now suspect that there is more than one version circulating about, but no matter, they all produce the same results. My assembled one shown here uses three dissimilar colorful woods, which will be automatically mated when assembled. The pieces shown are from a different one with two woods.

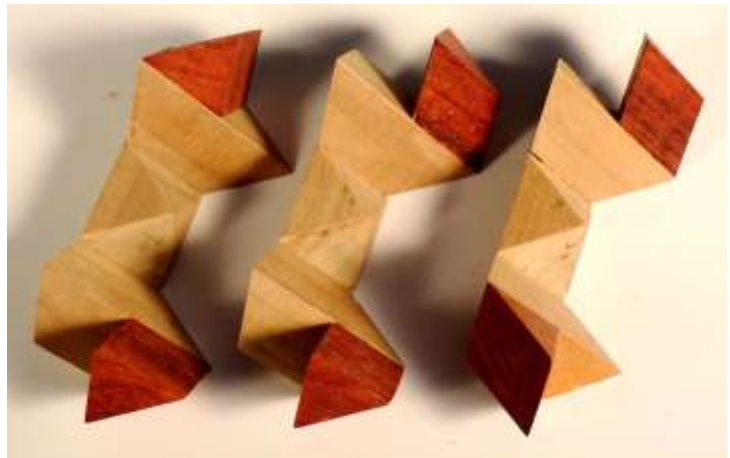
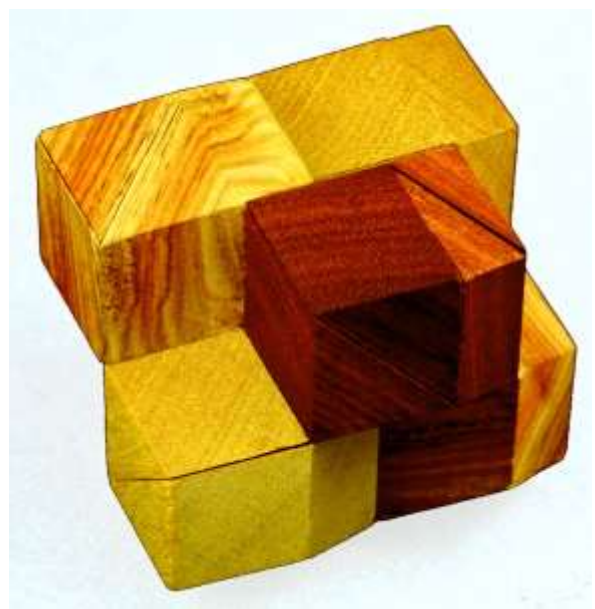

50. Superstar. It doesn't quite live up to its name. The six identical pieces mesh together easily in two identical subassemblies to form what is known by geometers as the third and final stellation of the rhombic dodecahedron. It is really more of a polyhedral sculpture than a puzzle, but it does create the interesting illusion of 12 triangular sticks, even though they are discontinuous. This model is in Honduras mahogany, one of my favorite woods.

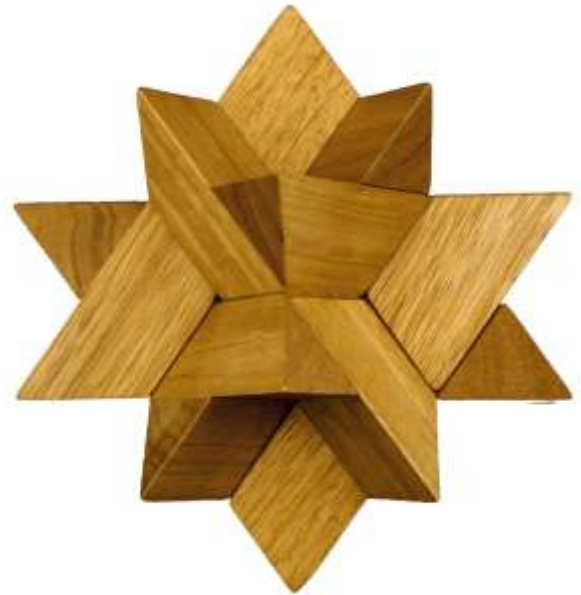
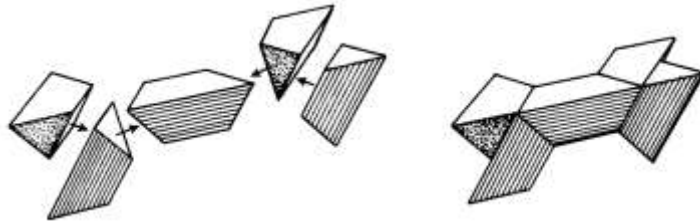

50-B. Third Stellation. To convert *Superstar* into more of a puzzle, I proposed making it in four contrasting woods which must then be matched so that the sticks will not appear "broken," and I published that scheme in my book *Geometric Puzzle Design*. I must have then wandered off to other projects, for evidently I never actually made one. Now to the rescue comes Lee Krasnow with one beautifully crafted in exotic woods. The diagram shows the coloring scheme. The woods appear to be wenge, padauk, walnut, and zebrawood.

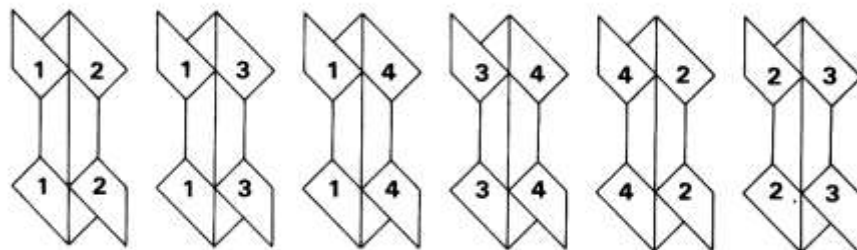

51. Little Superstar. It is a trivial variation of *Superstar* reduced to the shape of the second stellated dodecahedron simply by reducing the lengths of the 24 end components. Arrangement of the four contrasting woods is the same as on the previous page. Note also the similarity to *Nova #8-B*, the difference here being the use of triangular stock rather than square, hence the linear direction of the wood grain, giving an entirely different effect.



You may have noticed by this time that many of my polyhedral puzzle designs have a basic geometry that is becoming quite repetitious. I was well aware of that and always seeking alternate geometries, but not always successfully. Perhaps someone might ask, for example: How about making one with the shape of a stellated octahedron? But that is not the way it works. The shape emerges naturally from the structural scheme, not the other way around. Very early on I attempted to dissect a stellated regular dodecahedron into six puzzle pieces. It was a bad idea and ended up looking contrived. (I hope that whoever owns that ugly cast epoxy model now does not read this and have it spoil his or her day.)

52. Pennyhedron. Here's proof that entertaining geometric assembly puzzles can be made with as few as two pieces. Our three little girls used to amuse themselves in my workshop by gluing together wood scraps to make "puzzles" for their friends. And out of that came the *Pennyhedron*, so named because they used to put a penny inside. After they had made a few, the potential of their creation dawned on me. The two halves go together easily enough, but taking one apart is tricky because the natural thumb-and-finger approach just holds it more tightly together. Only an unnatural three-finger grasp works. But after having mastered that, other variations are possible where even that doesn't work. The possibilities are endless. When well made, the joints are practically invisible so you can't tell by inspection which is which. Artistic variations such as truncated or spherical in shape add yet more dimensions to this amusement. Who knows how many we made altogether, or how many different kinds.

At right, one made of rosewood is shown apart with a penny inside for scale. Above it are three made with various exotic hardwoods, of which my helpers had more than ample supply.



And then there was their half-scale *Minihedron*, shown here alongside the standard *Pennyhedron*, together and apart. Again Brazilian rosewood, an excellent wood for this because of its stability, plus of course good looks.

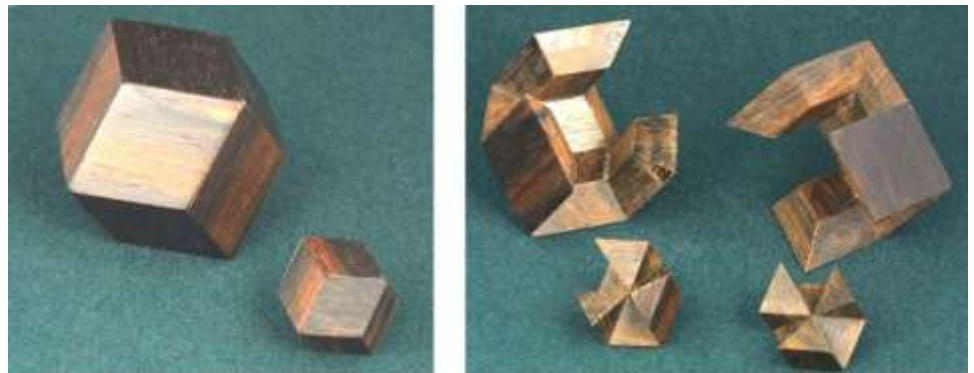

On the left, the standard *Pennyhedron* has been sanded down from a rhombic dodecahedron to a regular octahedron. On the right is more play, with a nondescript geometric solid having two square faces, four rhombic, and eight triangular. Both made with three contrasting fancy woods.

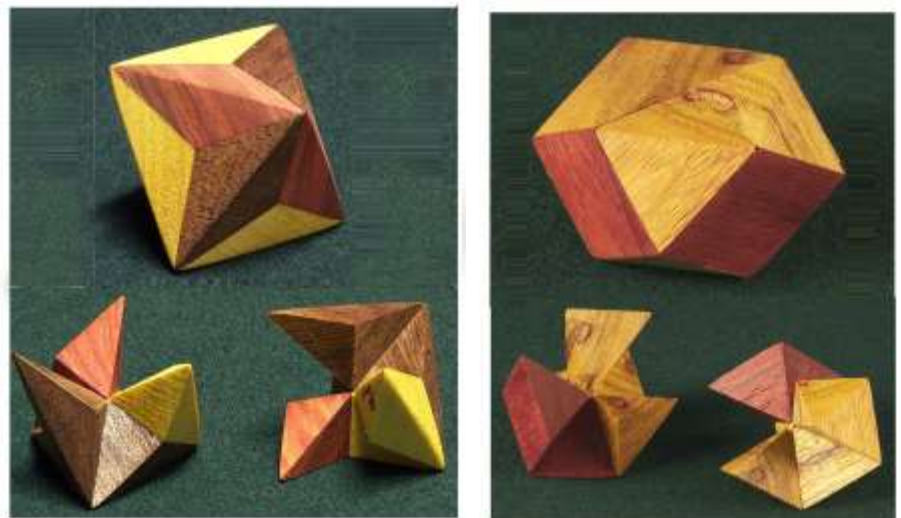

Yet more *Pennyhedron* play is suggested by the three geometric shapes shown here.

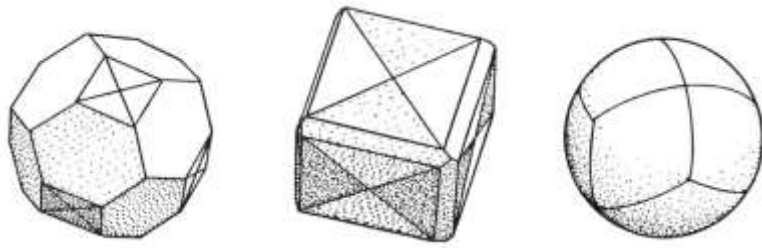

We had lots of fun with this three-piece version.



This symmetrical version in mahogany is especially tricky to disassemble.

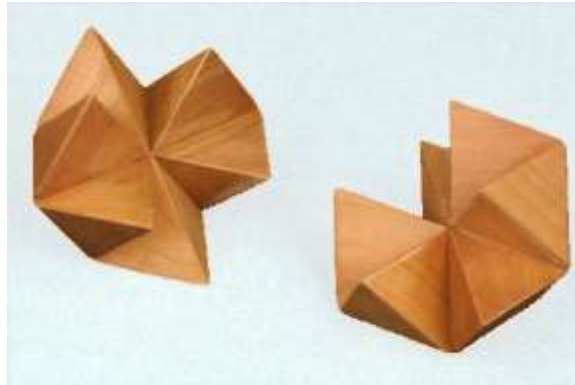

This is a non-symmetrical variation of the above in walnut



52.A. Hole-in-One. This was a simple three-piece coordinate motion puzzle with pin and hole, harder to take apart than put together. I designed it in 1995 as a possible IPP exchange puzzle, but I doubt if it was ever used and has since languished in obscurity, perhaps rightly so.

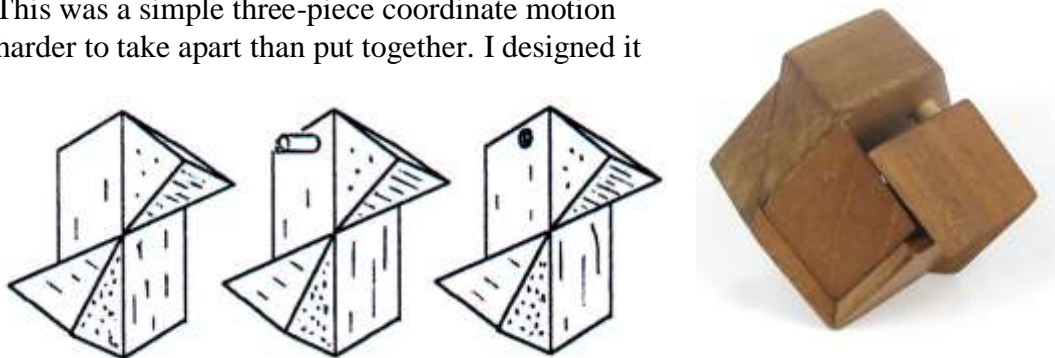

52-B. Button Box. This is a distorted version of the standard two-piece *Pennyhedron*, likewise hollow, but having the symmetry of a brick. An IPP exchange, presumably with a button inside..



52-C. Pennyhedron

Tricky Pair. It exploits a familiar trick in puzzeldom. Both versions look exactly alike when assembled. The one on the left comes apart with the tricky three-finger grasp, but when smart alecks try to take apart the one on the right that way, all they are doing is pressing it ever more tightly together, not realizing that all it takes is the normal thumb and forefinger grasp.

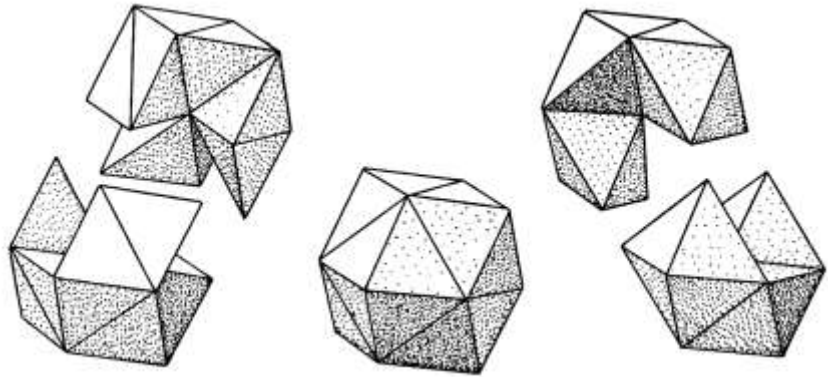

As I said, the possibilities are endless, of which I have shown here only a sample. George Bell and Stephen Chin have come up with some clever variations, but they are outside the scope of this *Compendium*.

53. Little Giant Steps. It was a frankly not very inspired variation of *Giant Steps* #10 made by shortening the six corners. Used six of each piece. Only three made in 1973.

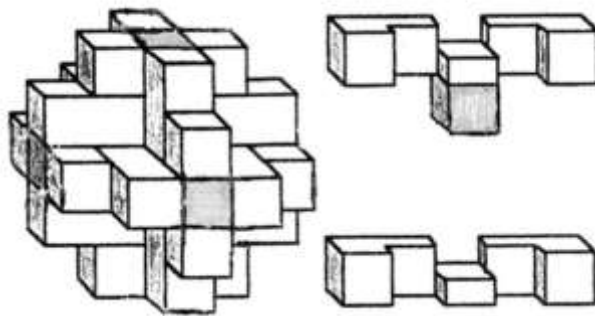
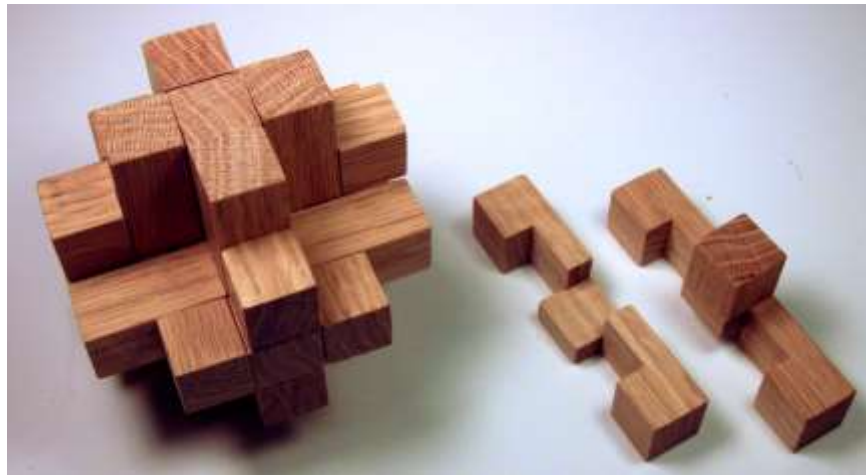

54. Defiant Giant. This was a complicated variation of *Square Knot* #9 with blocks added as shown. The numbers indicate how many of each piece are used to make up the 12 pieces. Thankfully, only one made in 1973.

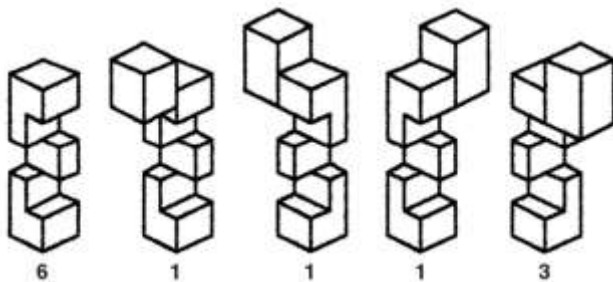

55. Pagoda. Eight cubic blocks, shown shaded, are added to the pieces of *Square Knot #9*. Three kinds of pieces, four of each. Ho hum.

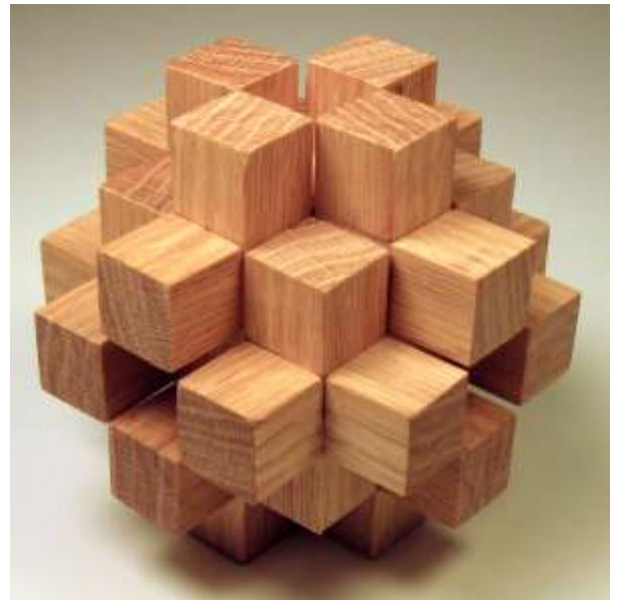
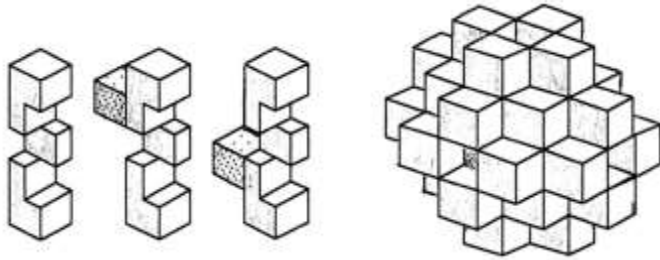

56. Giant Pagoda. This is a combination of *Giant Steps #10* and *Pagoda #55*, resulting in six kinds of pieces, two of each. One or two made in 1973 and the design notes were then lost, if in fact they ever existed. So I have reconstructed this from memory. Hope I got it right, but it probably doesn't matter. Not one of my better efforts.

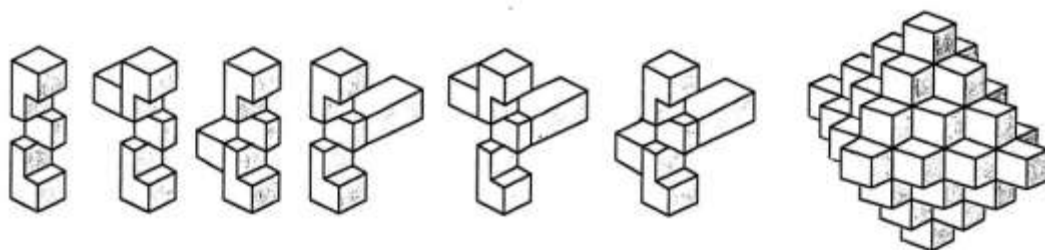
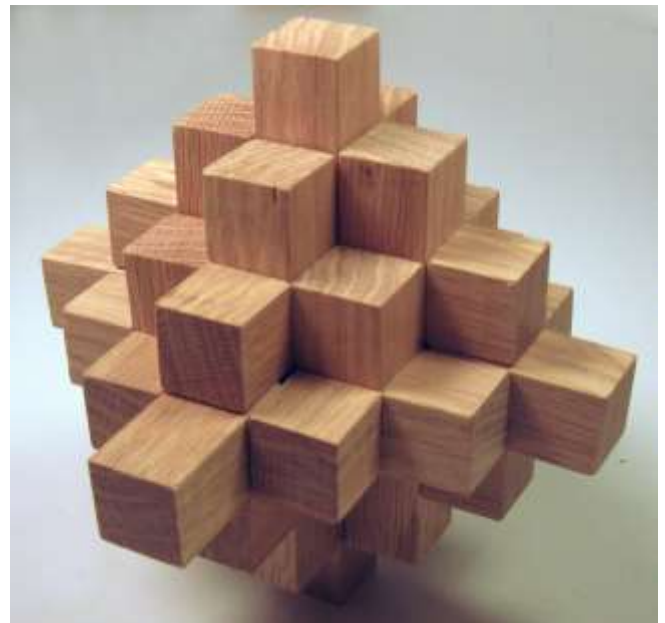

57. Plus 2. This is the name for my 14-piece variation of *Square Knot #9* otherwise known as the *Altekruse* puzzle. For the amusing story of its discovery, I quote from the 1985 edition a book of sorts I once self-published called *Puzzle Craft*: “I used to make this puzzle (*Square Knot*) in three contrasting fancy woods, one wood for each axis. Once when exhibiting at a craft show, I watched with considerable interest as a bright young girl named Marjorie Hoffman was amusing herself at my booth by trying to put one together in a strange new configuration. I later completed it and found to my surprise that it required fourteen pieces rather than twelve.”



Ever larger assemblies with more pieces are possible, such as these two examples with 24 and 36 longer pieces. I made a few of those too. I wonder if all this may have been discovered independently by others. But the real puzzle is what became of Marjorie. That show, by the way, was in Rhinebeck, New York, in 1973.

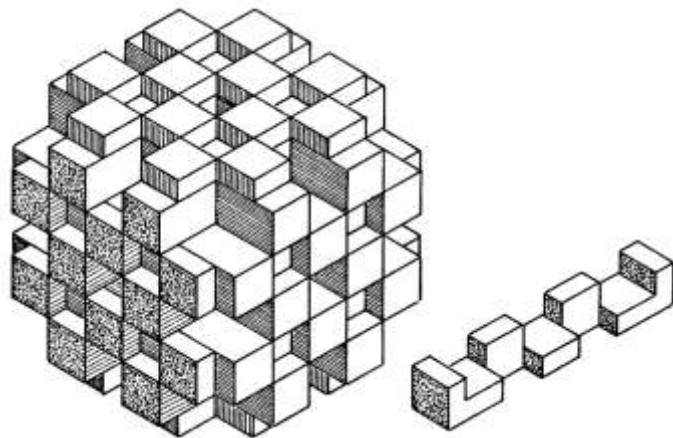
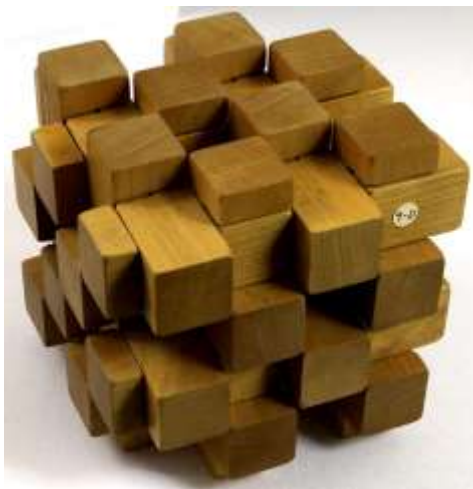

58. Diagonal Cube. Here is an example of the recreations that lie waiting in store for the curious and reasonably equipped woodworker. The six dissimilar and non-symmetrical pieces are made up of light and dark blocks similar to many others already described, using standard AP-ART building blocks (see Appendix). It is assembled one way only by mating two 3-piece subassemblies along a diagonal axis: 123 + 456 as shown below. But then the six faces are sawn and sanded down by whatever amount one chooses to achieve an entirely new look approaching that of a cube, and with attractive diagonal face patterns, seen here in mahogany and rosewood. That is similar to the operation shown previously for the *Augmented Four Corners* #34. So one then has to wonder, what other such artistic possibilities are yet to be discovered just by this simple process of reduction. I am pleased to see that this puzzle has caught the fancy of several other woodworkers. Assemble 123+456.

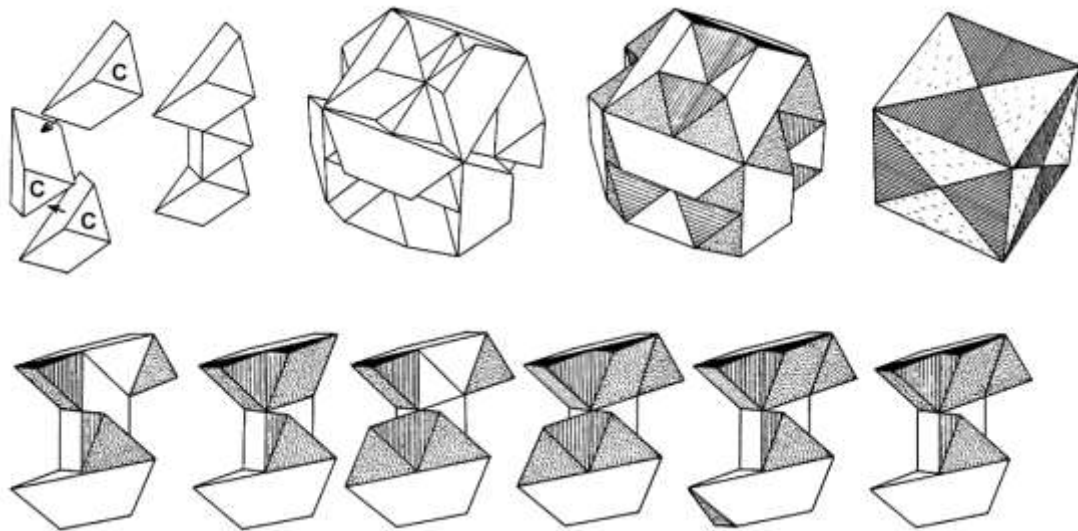

59. Corner Block. This is the old *Pin-Hole* #20 with eight corner blocks added judiciously, turning it from a pastime to a real but not difficult puzzle. It is assembled in the order shown, with the locking pin going in last. Made here in mahogany and rosewood, with birch pins.

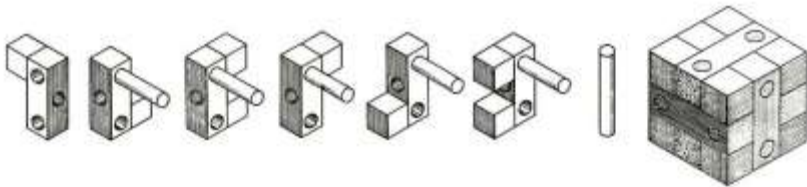

59-A. Improved Corner Block. The term “Improved” comes up frequently in these names of my designs. I could probably spend forever trying to improve some of them (or this *Compendium*) without ever being completely satisfied. It would be hard to guess how much time I used to spend daydreaming and tinkering, always searching for new ideas, instead of actually producing. My workshop was a converted greenhouse, with much south-facing glass and passive solar heating (see page 10). It was especially conducive to daydreaming in the winter, with the warm sun streaming in and classical music from NPR resonating around the large room.

The same photo serves for both this design and the previous one.

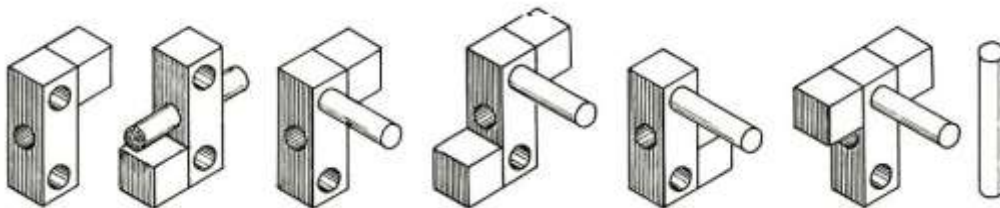

Improved Cornerblock has two solutions, as did all my other experimental versions, whereas only one would have been preferred. To digress slightly from the theme of this book, here is a puzzle for geometrical analysts: Try to figure out why, no matter how the corner blocks are attached, the solutions tend to mysteriously always turn up in pairs. Or do they?

60. Garnet. Yes, the shape of the natural garnet crystal really is a rhombic dodecahedron. *Garnet* has a shape that is completely convex, thus allowing the assembled faces to all be brought to a fine finish by sanding and polishing. And what fun working with all these brightly colored woods. The six dissimilar non-symmetrical pieces assemble one way only. The final step of assembly is the mating of two halves of three pieces each. Again, appearances can be deceiving - the design is most closely related to that of the *Scrambled Scorpius* #23.

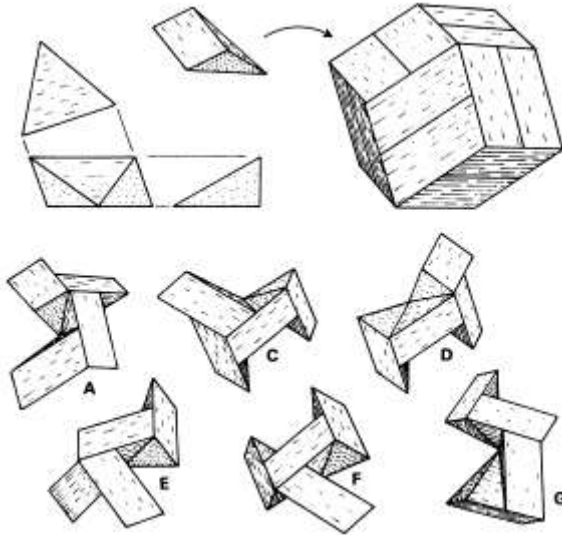

The graphic above shows the six Garnet pieces A C D E F G and how they are made by joining four identical triangular blocks different ways. The blocks are sawn at odd angles from sticks of 30-60-90 degree cross-section.

But that's just the beginning of the story. There are nine possible non-symmetrical four-block pieces, as shown below. For solutions with all dissimilar pieces, three combinations are known to be possible; the one above and just two others: A B C D E F and A B C D E H.



If duplicate pieces are used, 203 combinations are known to be possible, but that includes a few that require looseness or rounding of edges to assemble. All of this has been investigated exhaustively by Bob Finn and myself, and summarized in about 50 pages of tables and diagrams. Obviously way too much to include here. And vastly more solutions are possible if one includes three-block and five-block pieces as well. Some of these make quite novel puzzles. Perhaps someday we will issue a report on what we called our Garnet Project, which probably barely scratches the surface of this fascinating recreation.

Another unusual property of *Garnet* is that the faces of the assembled puzzle can be cut down to any desired shape such as octagonal or spherical for interesting variations. This beautiful spherical model was expertly crafted by Josef Pelikán. Other possibilities are truncated and octahedral, as suggested by the drawings below.

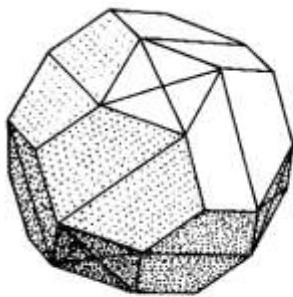

Truncated

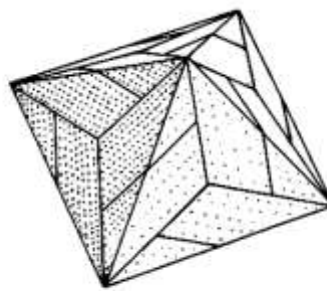

Octahedral

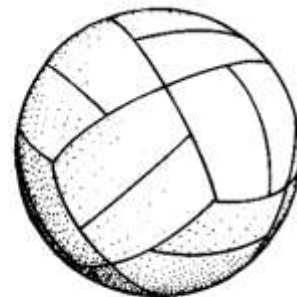

Spherical

61. Setting Hen. The four pieces of *Setting Hen*, each made of rhombic dodecahedron blocks joined together different ways, fit flush into a cubic box. The idea behind the name was that the pieces can be packed in such a way as to suggest Mother Hen sitting on her next of eggs with just her head poking out above the rim, assembled as shown in the graphic. The task then is for her to duck down flush with the top of the box. Such blocks do not lend themselves well to cubic packing, and so this design was soon superseded by *Distorted Cube* #61-A.

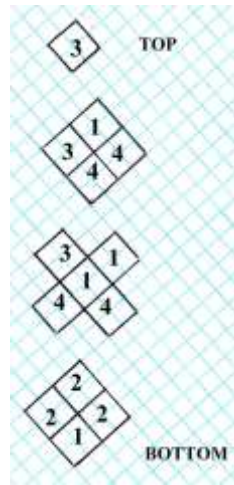
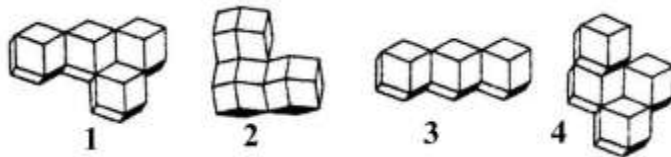

61-A. Distorted Cube. This “improved” version overcame the awkwardness of packing puzzle pieces made of rhombic dodecahedral blocks into a box by instead using edge-beveled cubes. The tricky box converted from cubic to rectangular, and the four pieces fit in either way. But in retrospect, hardly worth all that extra complication. A better design might have been just a plain cubic box with the one simple packing problem.

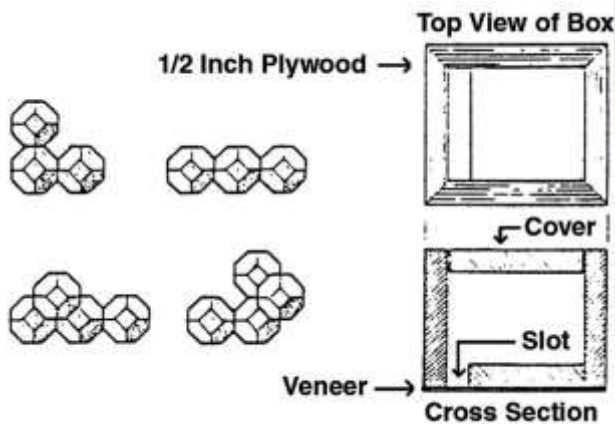

62. Nine Bars. With any new design concept, much time may be spent making very accurate sawing or drilling jigs. In the case of locating and aiming drilled holes, there are often three or four degrees of freedom that all have to all be adjusted just right. Once done, though, there is the tendency to investigate other practical uses for the same setup. And that is the story of *Nine Bars*. It is made with the same setup as *Cuckoo Nest* #21. It is believed to have only one solution. Although it may not be obvious in the photo because of the angle taken, *Nine Bars* has a three-fold axis of symmetry. Think of it as a *Cuckoo Nest* with extra layer added. This model is in birch. Pieces are numbered in order of assembly.



63. Pseudo-Notched Sticks. There is a simple puzzle that has long been in the public domain known as the six-piece diagonal burr, as described in my *Geometric Puzzle Design*. I have made a few but do not include them in my listing. *Pseudo-Notched Sticks* looks exactly like one, but when you try to take it apart by the usual way of pulling on any two opposite pieces, all you are doing is pressing it ever more tightly together. Grasp it in a way that seems to make no sense at all and apart it comes. Just my idea of a novelty or practical joke. For more fun, it can be expanded in all directions almost to the point of collapse, as suggested in this photo.

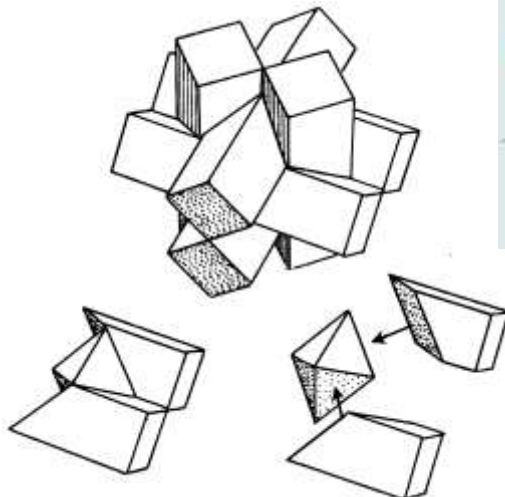

64. Expanding Box. More of a novelty than a puzzle, the six identical pieces of *Expanding Box* insist on coming together or dancing away from each other in perfectly symmetrical coordinate motion. This model is in canarywood.

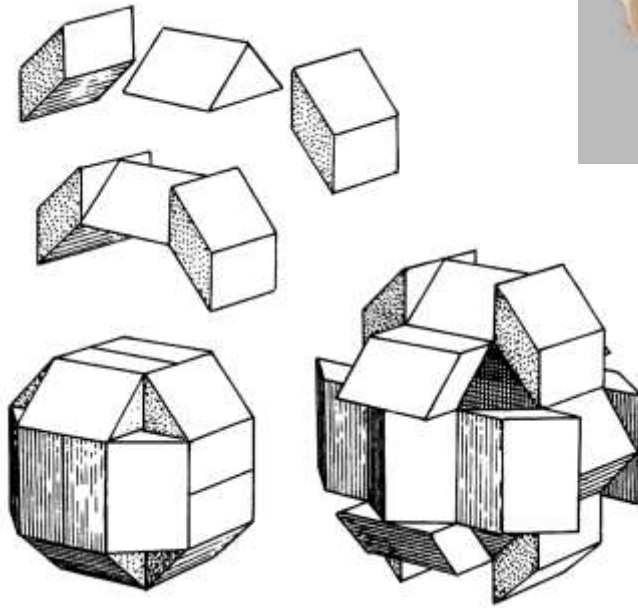

65. Thirty Notched Pentagonal Sticks. When a photo of this experimental and long-forgotten model of *Thirty Notched Pentagonal Sticks* was included in a large batch of photos from John Rausch, I had to do some research to figure out just what it was. I finally found it described on page 146 of my *Geometric Puzzle Design*. Notice that each stick intersects with five others and must be notched accordingly. It turns out those notches are so deep that they would likely cut the sticks into pieces. So this is probably just a glued-up sculptural model that doesn't come apart.



At the same time I made another with all the sticks rotated 36 degrees, and evidently those pieces did survive the notching, but barely so (second photo). Just a pair of curiosities and not really even AP-ART.



And in this same batch of photos comes another 30-piece oddity. I do remember making this experimental plastic model way back in the epoxy-casting days, around 1970. As I recall, five of the pieces were without notches on one end to permit assembly, although the photo offers no clues. I wonder where it is now.



65-A. Thirty Notched Rhombic Sticks. This one also comes under the category of an experimental model, or sculpture, that never went anywhere except, surprisingly enough, onto the cover of my *Geometric Puzzle Design*. If you look closely you will notice that one of the sticks has an incongruous triangular end rather than rhombic. As I recall, there are five such odd pieces that are necessary to permit assembly. That plus the large number of pieces tended to limit its appeal except perhaps as a curiosity. I probably made only this one, of southern yellow pine. By the way, I had nothing to do with the design of this book cover. If I had, these are certainly not the designs I would have chosen.

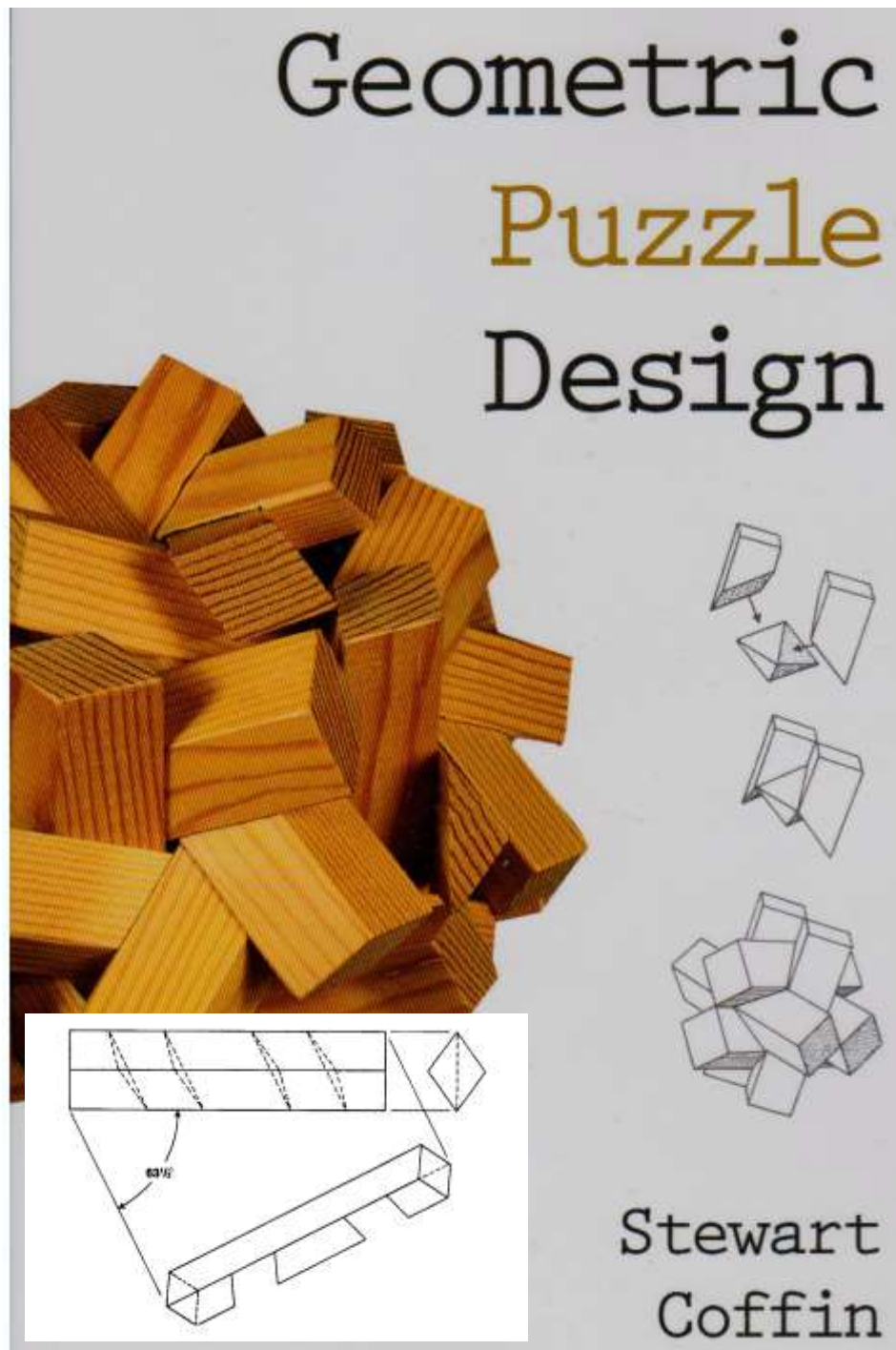

66. Crystal Blocks. The six puzzle pieces of *Crystal Blocks* were made from 22 rhombic dodecahedron blocks joined together different ways. I cast them in clear epoxy way back in 1971 and listed many possible constructions, all with the vain hope of licensing the puzzle set for manufacture. After gathering dust for years in the recesses of my workshop, they probably eventually ended up in someone's collection. In looking back now, I realize that my *Crystal Blocks* had little potential as a marketable puzzle. The real payoff was the fun that I had discovering the various constructions: small tetrahedron, large tetrahedron, octahedron, square pyramid, rectangular pyramid, and many others still recorded in my files. I should also mention the fun that computer expert Mike Beeler must have had determining the number of solutions for each construction, as indicated below. There were a few other similar experimental sets of pieces, but this one received most of our attention. And now, after all these years, here finally is a set in wood.



Small tetrahedron
8 solutions



Large tetrahedron
2 solutions

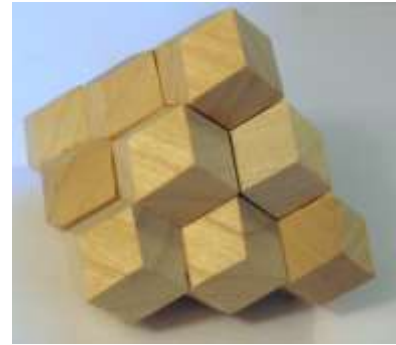

Square pyramid
20 solutions

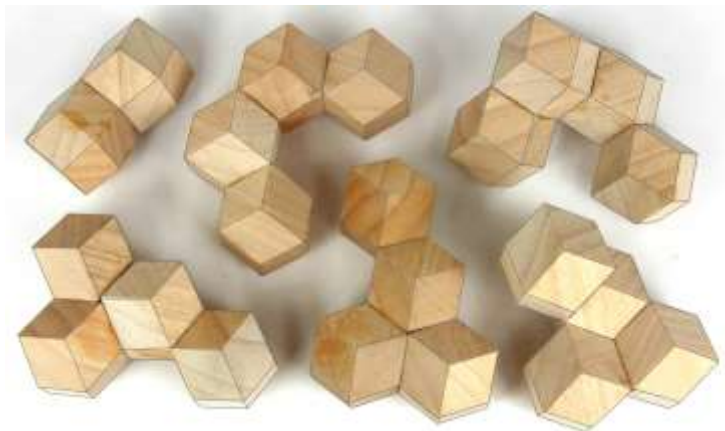

67. Peanut. The six polyhedral pieces of *Peanut* fit together many different ways to construct the various shapes shown on its accompanying instruction sheet. The pieces need to be very accurately made, but when they are, it becomes a delightful and attractive set of pieces to play around with. I made a few such as this in mahogany, and would have made more but for the many parts and glue joints, and the accuracy required.

In my descriptions of *Peanut* in both of my previous books, I purposely left out a detailed description of the pieces so others could have the same fun that I had experimenting with different combinations of the 20 possible pieces. Looks like that happened because several variations have been made by others. But here is my original 1973 design, which Mike Beeler determined was the only combination capable of assembling all of these problem shapes. The number of solutions for each is shown. For more information, see *Puzzle Craft 1985* and *1992*.

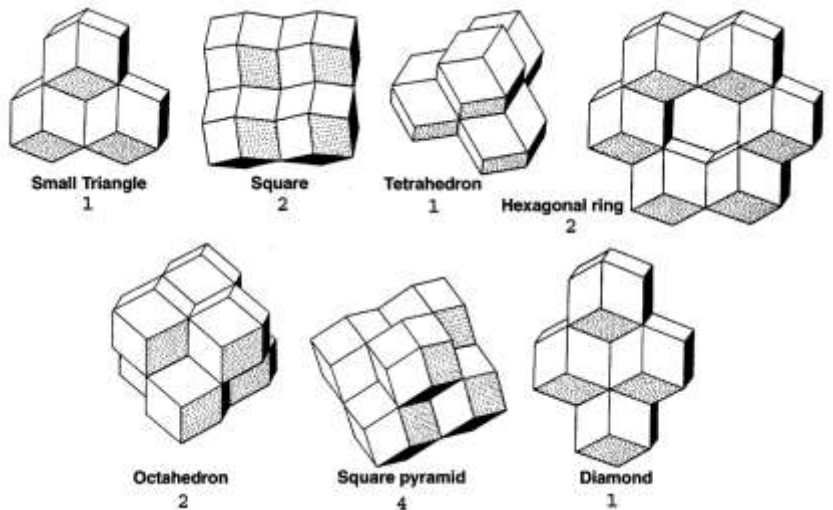
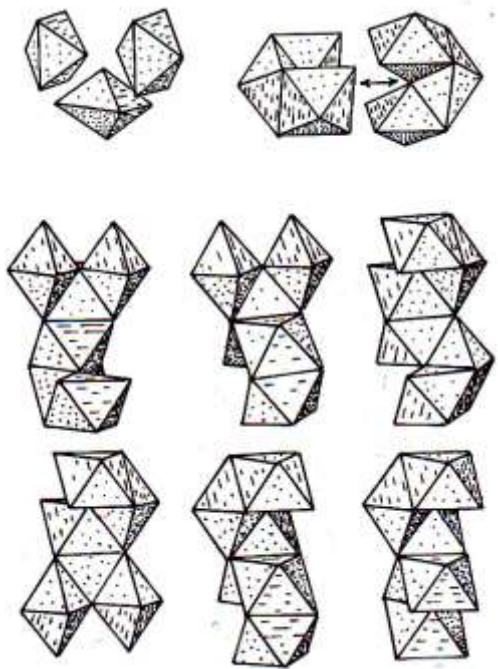

67-B. Pennydoodle. This is a sequel to *Peanut*, based on the three-prong bisection of the *Pennyhedron #52* rather than two-prong. The instructions showed eight possible symmetrical constructions. Its 48 rhombic building blocks must be sawn and glued accurately, and of stable woods to prevent binding. I laboriously crafted a few sets around 1990, some in multiple woods and some in mahogany. Fine reproductions have been made by Josef Pelikan.

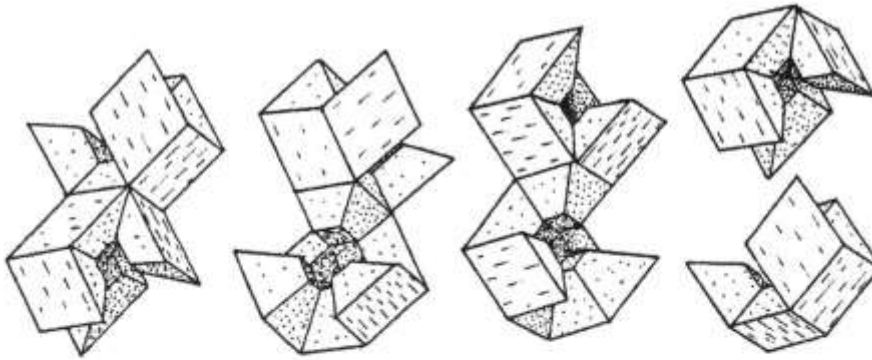

Tetrahedron
1 Solution

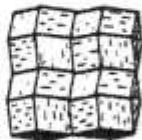

Square
1 Solution

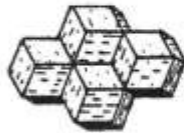

Diamond
6 Solutions



Straight
3 Solutions

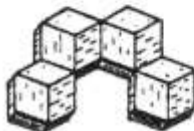

Arch
5 Solutions

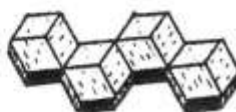

Snake
6 Solutions



Zig-Zag
2 Solutions



Angle
6 Solutions

68. Confessional. When one's livelihood depends on coming up with ever newer ideas, sometimes desperate measures must be taken. And so it was that I took several existing designs and proceeded to distort them into slightly non-orthogonal (not right angle) axes. Part of the incentive was that it was fun to do the calculations, work out the solutions, and make the special saw jigs. Math was my favorite subject throughout school, and recreational math one of my favorite pastimes, so it comes naturally.

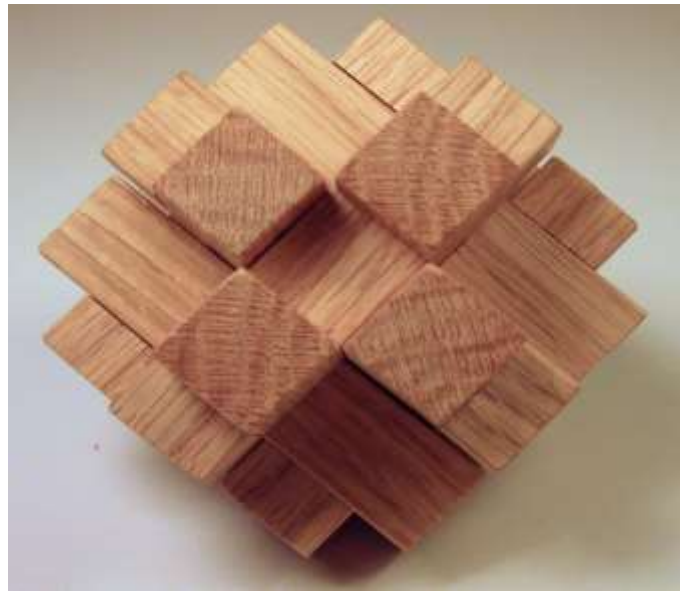

In *Confessional*, all three axes of the *Square Knot #9* are tilted by five degrees, making the cross-section of the pieces rhombic and the assembly more complicated. It is also harder to fabricate unless one invests in a custom cutting tool of some sort, which I never did or I might have made lots more. I used laborious multiple saw cuts. The assembly has only one three-fold axis of symmetry. The photo is taken viewing perpendicular to that axis, showing the rhombic cross-section.

When I first produced these in 1994, I was naively unaware of the amazing complexities of this seemingly simple variation. In the process of compiling this *Compendium*, I have taken time off attempting to unravel them. Here is what I have discovered so far:

In selecting a set of 12 triple-notched pieces, there are four kinds to choose from. What I didn't realize until recently is that there are actually two independent sets of pieces, and the two sets are incompatible with each other. (In my drawings the angles are exaggerated for illustration.)

Any solution with one set will also work with the other. However, the set on the left (labeled prime) will produce a solution with upright three-fold symmetry, whereas a solution with the set on the right will be squat. Perhaps it is apparent that the example in my photo is squat.

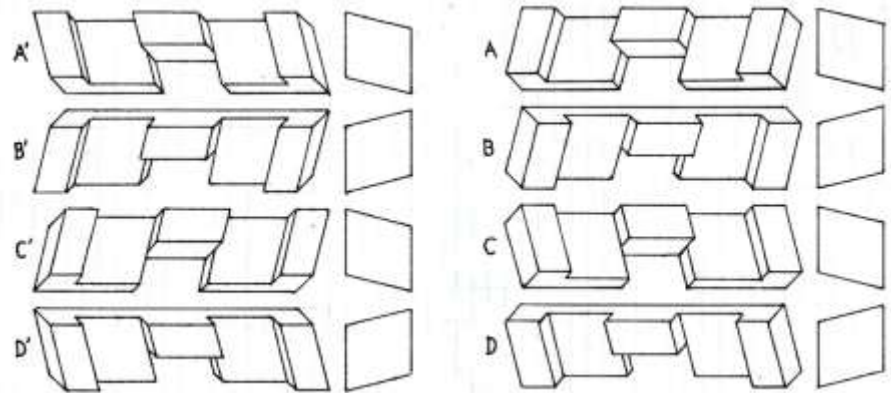

I discovered all this by accident when I recently did a re-run of this puzzle. When I was forced to look up my old assembly directions, they made no sense because I had unknowingly switched from one set to the other. In setting up the saw jig to make the slanted notches, there are three angles to consider: the tilt of the rhombic stock, the tilt of the saw, and the angle of feed. Change any one, and you switch from one set to the other. Change any two, and you are right back where you started. Confused? No wonder, so was I.

What remain to explore are all the different possible combinations of pieces and their solutions, some of which will be much more interesting than others. Then there is the possibility of using three contrasting woods, with two different possible arrangements with color symmetry. Of all the unfinished

explorations mentioned in this *Compendium*, I think this is one of the more promising. And by the way, don't ask how I came up with the name for this puzzle because I can't remember.

Caution: In 1984-1985, I made and sold about 150 puzzles in this class of 68, 68-A, and 68-B. I randomly assigned identification letters on some of the puzzle pieces and instruction sheet, which are likely to be different from these. At that time I was ignorant of the two distinct sets. Those letters should be considered obsolete. The systematic lettering shown here is the one to use instead. Note that A and C are mirror image, likewise B and D. Important: note also that the pieces shown above are four notch widths in length, whereas the next two designs in this series are five units in length, which leads to some further complications in solving.

When and if I ever have the time (and energy!), I would like to explore this category of puzzles further, with lists of possible combinations, and with well illustrated and easily followed assembly instructions, perhaps to be disseminated as a separate report. But right now I am struggling just to finish this *Compendium*, so perhaps others will take an interest in this fascinating subject.

68-A. Leaning Tower of Altekruse. This is a 14-piece version in this family with rhombic cross-section sticks, corresponding to the 14-piece variation of the classic *Altekruse* that I call *Plus 2*, #57. The name came from the late Edward Hordern, who used it as his exchange at the International Puzzle Party in 1995. Again, observe that this is the squat version.

There are at least four practical combinations of the four possible kinds of pieces, some easier than others. I once attempted to tabulate them all, and I still have the results, but I leave to others the fun of investigating them again and perhaps discovering some I may have overlooked. I believe that the IPP exchange version used 12 A pieces and two B pieces.

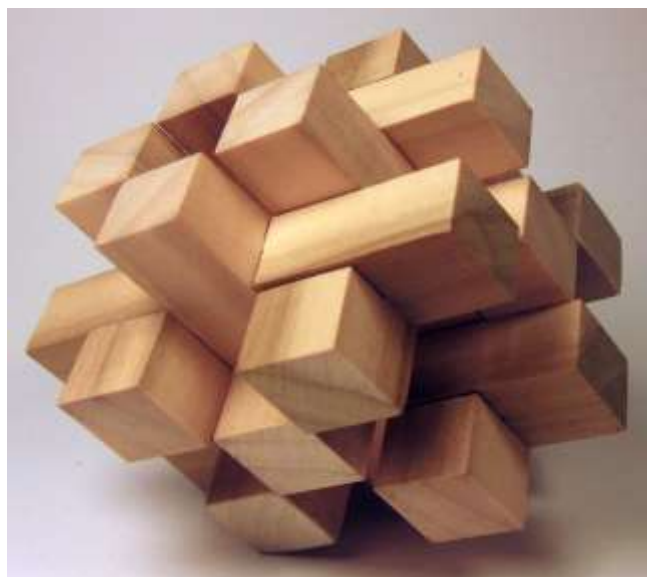

68-B. Confessional Plus. This is the most interesting version. It has pieces five units in length rather than four. In a departure from my usual practice, these came with explicit assembly directions. If a manufacturer wanted to invest in the necessary cutting tool, this gem would be the one to make. But please change the name.

There is a relatively simple version using four A pieces, four B pieces, and four D pieces. A more interesting version uses eight B' pieces and four C' pieces, and involves tricky rotation.

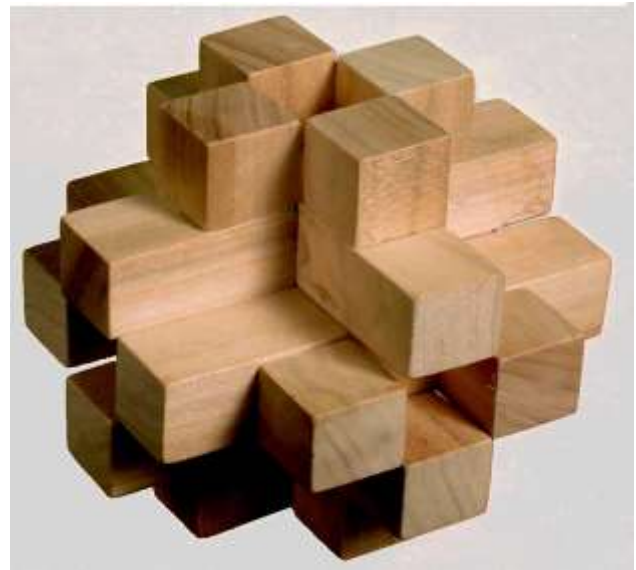

Notice I did not use the word “puzzle” in describing the *Plus* version. When supplied with directions for assembly, it is no longer a puzzle but becomes instead a fascinating exercise in assembly. One reason for this is that without the directions, the pieces might forever remain unassembled. What a shame. The other reason is that the unusual way they go together is quite amazing and something to be enjoyed in itself.

Of the four possible kinds of pieces and many combinations of them, *Confessional* #68 and #68-B both use combinations of pieces. Why not all alike? It would certainly be easier to fabricate that way, and you might think also easier to solve. Perhaps you might suspect I just wanted to introduce an added level of complexity (which I have been known to do). But the reason in this case is that 12 identical pieces cannot be assembled. Other combinations of pieces are possible, and the puzzle world awaits some keen solver to come up with a complete analysis.

The final step of assembly for all puzzles in this family is the sliding together of two halves.

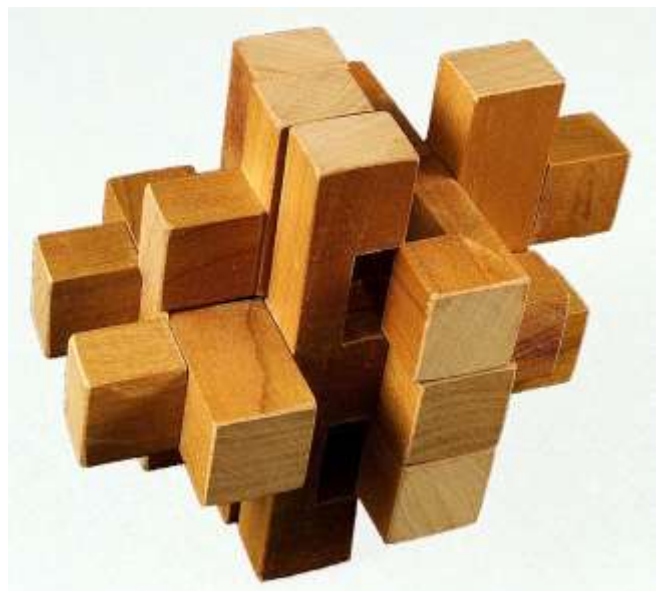

71. Stucksticks. This was the first of several attempts to make *Hectix* #25 more interesting by joining some pieces in pairs. In this one, four pairs of standard pieces are joined to make elbow pieces. (You can trace the development of this idea through #140, #159, #159-A, and finally #159-B.)

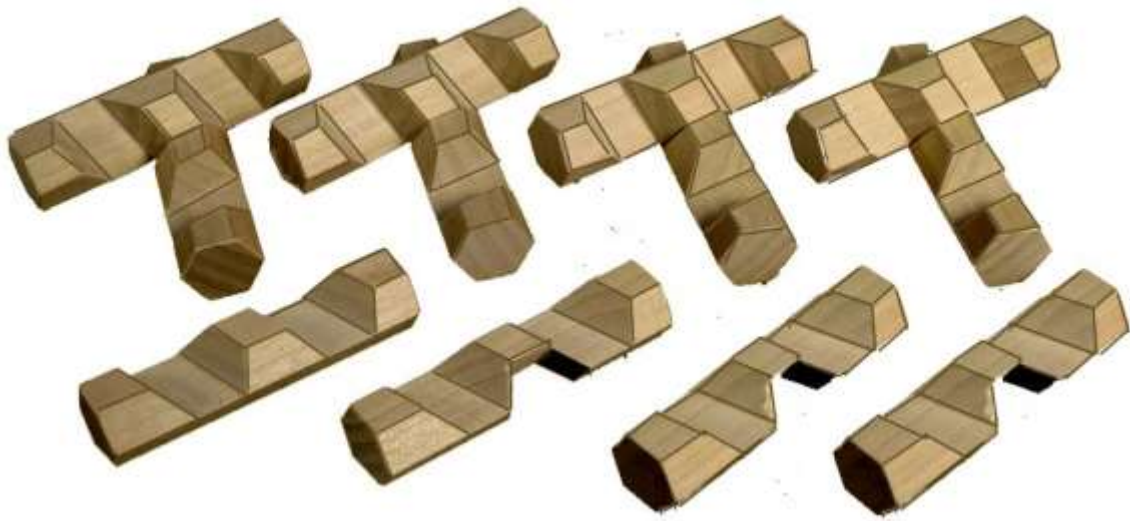

72. Design No. 72. Yes, sometimes I simply run out of names. *Design No. 72* has the shape of the rhombic triacontahedron. Think of it as a *Garnet #60* with 30 faces rather than 12. It uses five kinds of pieces, two of each (see next page). The final step of assembly is the mating of two identical halves. It makes an attractive sculpture when crafted in fancy woods, but because of its complexity it lacks much appeal as an assembly puzzle. The second photo shows the two halves mating. The third photo shows an experimental variation sanded down to a more nearly spherical shape.



The drawings show the makeup of the five pairs of dissimilar pieces. Each identical half is assembled by matching the lettered blocks in pairs. The two halves are then mated to complete the assembly. It has been reported there is more than this one solution.

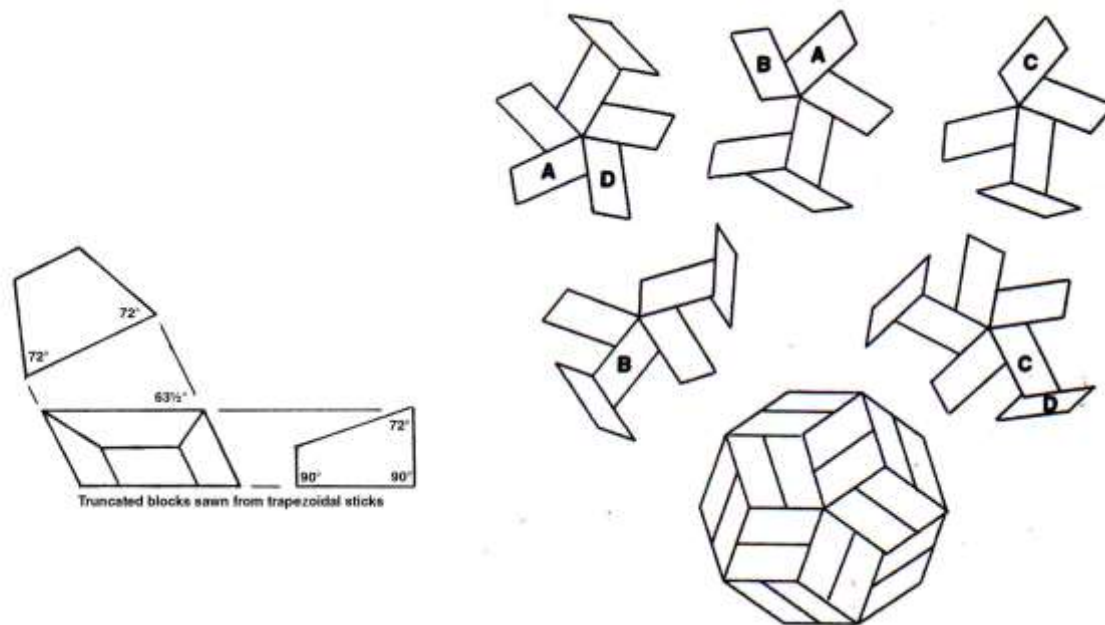

Included for your amusement is a photo I recently received by surprise from Nick Baxter. It shows a jumbled pile of a hundred or more experimental pieces for possible use in this type of construction. I am guessing they represent, if not all possible six-block pieces, at least most. Surplus parts like these have a way of accumulating in my workshop, so I must have been glad to send them off to a good retirement home.



73. Seven-Piece Third Stellation. The idea behind *Seven-Piece Third Stellation* was to depart from the now all too familiar six-piece puzzle assembled by mating two halves, and depart it does. Assembly requires coordinate motion of the first three pieces, with the remaining four being serially interlocking. So finally we have a polyhedral puzzle with a traditional “key” piece. Too bad so few of this interesting puzzle have been made. I am not aware of any reproductions. One reason may be that it was inadvertently left out of both of my previous books. A four-color version (see below), might make an attractive variation. Assemble in the order shown. For more assembly directions, see *Fancy This!* #115, which is basically the same design but made with shorter components.



73-A. Seven-Piece Third Stellation, Modified. The pieces of this version differ only slightly from #73, but that slight difference makes assembly much harder, involving coordinate motion with rotation followed by serial interlock. It came with assembly directions. I made only ten, in four contrasting woods, arranged symmetrically of course, for whatever slight help that might offer. Perhaps another reason for using four woods is that otherwise one ends up with two identical pieces, #2 and #3. Note in these diagrams that the center blocks do not quite come to a point in the center, but are instead cut off. Without this modification, the puzzle is impossible to assemble, and the degree of cutting off can change the puzzle anywhere from difficult to nearly impossible. Assemble in the order numbered.



74. Square Face. It is made by adding 12 more blocks to *Pseudo-Notched Sticks* #63, making six dissimilar non-symmetrical pieces. It has two solutions.

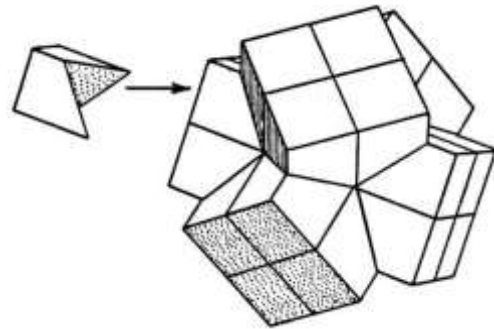
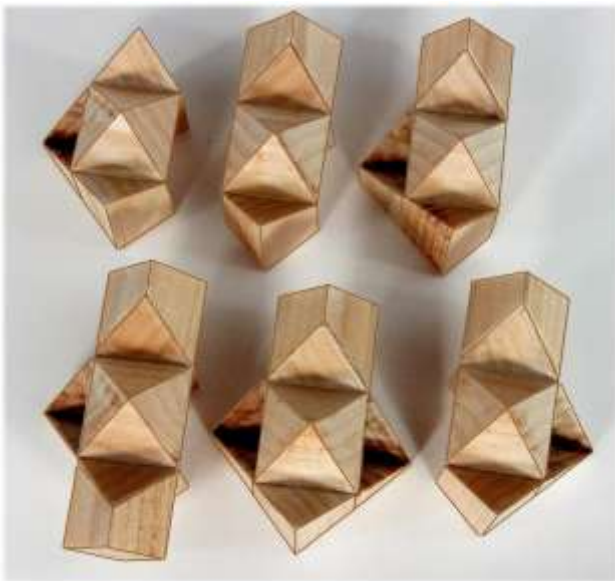

74-A. Square Face Variation. It has the same assembled shape as the above and is made by attaching those same extra blocks, but this time to the standard six-piece diagonal burr. The top three pieces assemble with coordinate motion, 1-2-3 clockwise. The bottom three pieces are serially interlocking, 4-5-6 counterclockwise. The two halves both have three-fold symmetry, and there is *essentially* only one solution.



75. Split Star. This is the next, after #72-A, of what I thought might be a promising new category of designs – one puzzle enclosed within another. But the idea never went very far, and difficulty of making was probably the main reason. The inner core is essentially a *Garnet* #60, and the outer is the first stellation of the rhombic dodecahedron. But a novel variation reappears as #165 in my listing. First photo is one of the four I made in applewood. The multi-wood reproduction was expertly crafted by Lee Krasnow. Details on next page.

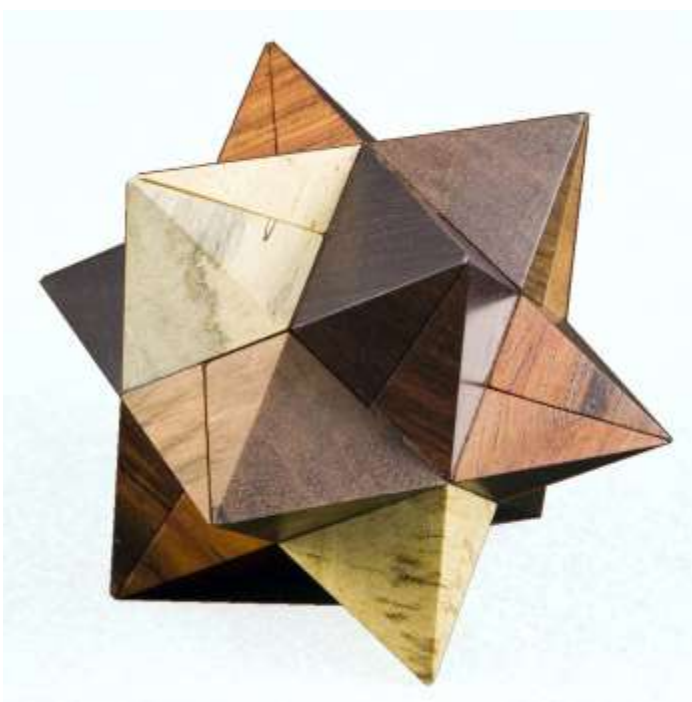

The photos below, of a more recent model in maple and poplar, give at least some idea of the construction. In this model, the inner blocks are truncated. The inner and outer are joined by their half-faces. The final step of assembly is to join two subassemblies of three pieces each.

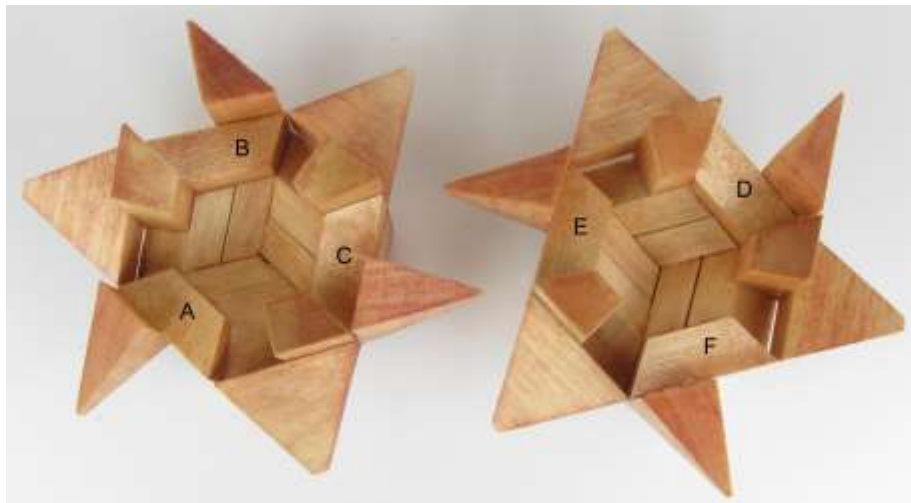

75-A. Two Tiers. “This is a *Garnet* within a *Garnet*. I never actually made one. It exists only as a drawing that first appeared in *The Puzzling World of Polyhedral Dissections*, where it occupies an entire chapter. I suppose it might make a satisfactory puzzle for some skilled woodworker willing to take all the extra steps, but it was invented merely to accompany a fanciful story of sorts. Too complicated to explain here, but here I have reproduced the illustration used in the book.”

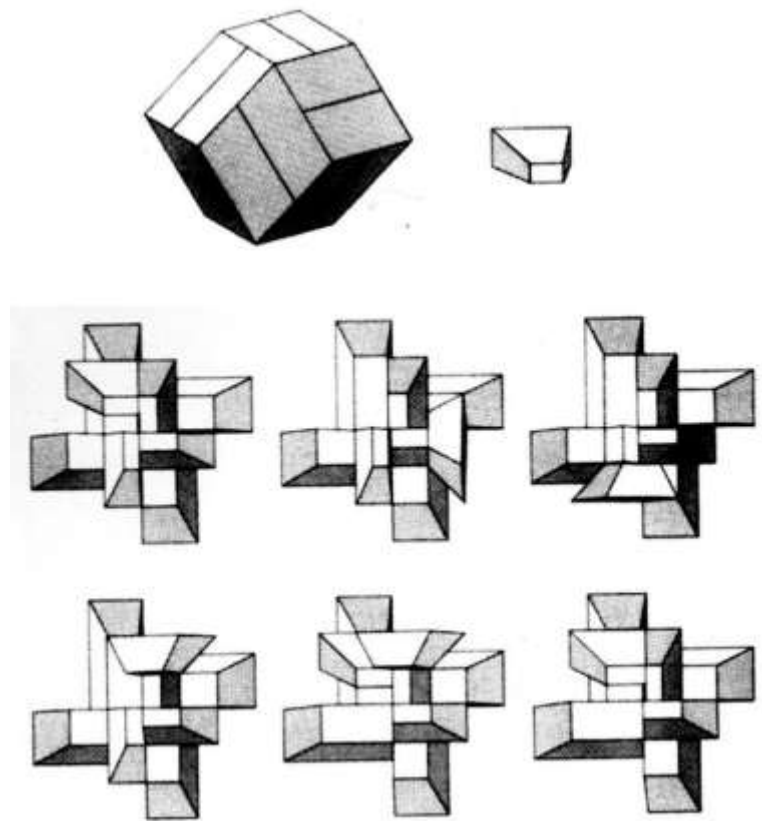

The above text was written in 2013. Subsequently I have made a few of these. So without going into the whole story, here is the gist of the puzzle. The inner layer would be the standard *Garnet* construction except that the piece top center (below) has one block broken off. This gives rise to two solutions, so the puzzle is to discover both of them with the broken off block loose inside. (For details, see X-5 and X-12 in Part 5.)

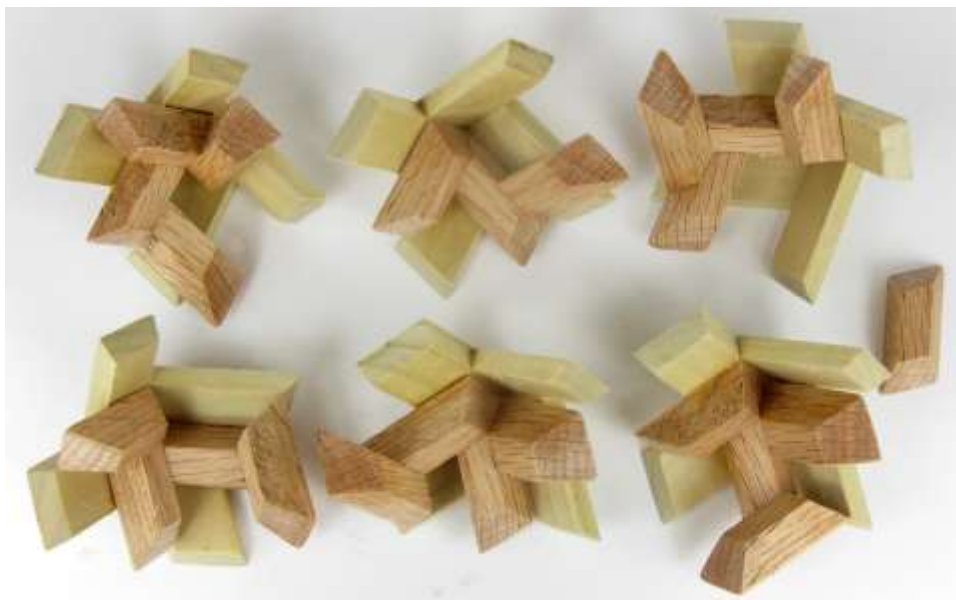

76. Cornucopia. More than a puzzle, or even a family of puzzles, *Cornucopia* was the name given to an interesting project in recreational mathematics. The idea was to select any ten pieces from a set of 17 non-symmetrical hexominoes (first drawing) and try fitting them into any one of ten different symmetrical trays (second drawing). Expert analyst Michael Beeler found by computer 8203 possible combinations with solutions and printed out about a thousand of them to be used. The idea was that every collector could obtain a puzzle that was unique. I made and sold possibly 100 sets, mostly in oak, and of course true to the name each one was different. (Later I made a few sets in colorful exotic woods, one wood for each piece, see #168.)

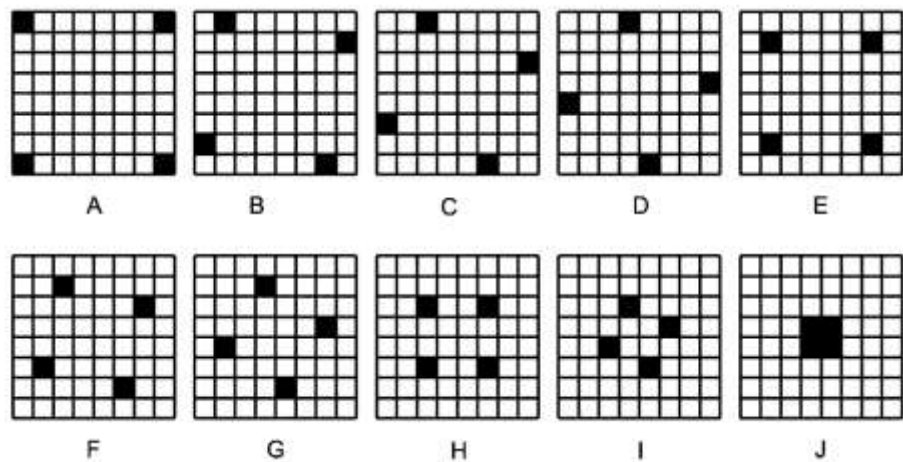
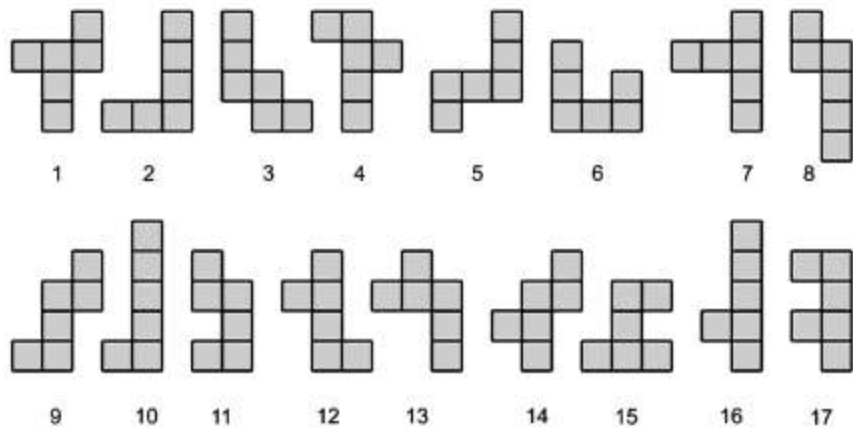
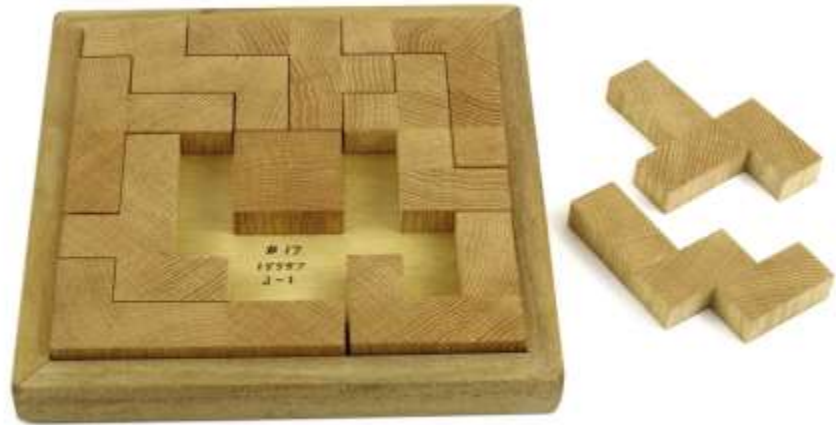

The Cornucopia project never quite lived up to its colossal potential, and I use the term “colossal” jokingly. Who wants to spend countless hours searching for the one or few solutions from among the billions of wrong starting placements? Note that I did not say randomly searching, for nothing one does with puzzles of this sort is random, and one gets better with practice. But in answer to my question, evidently some people just like to collect puzzles and such. If I were to be given one disassembled, I would be tempted to use any one of several computer programs to do the job of assembly that otherwise might take months. I have one such program installed in my computer called Puzzlesolver3D that will not only solve puzzles like this in seconds or less, but report how many solutions exist, display them in contrasting colors, and print them.

There were a few combinations that drew our special attention. One was *Copious Cornucopia* singled out by computer from among the 8203 possible combinations because of its unique versatility. It alone will assemble in nine of the ten trays.

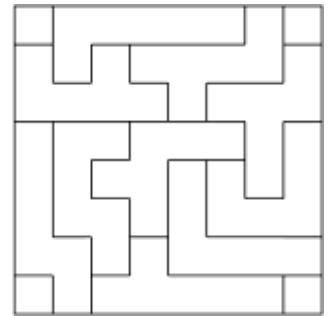

Another was *Cornucopia 107,715*. It and it alone has a unique solution with either the four corners or the four center squares blocked. A few others were singled out for special note, and more details about these may be found in my book *Geometric Puzzle Design*. One version became an IPP exchange.

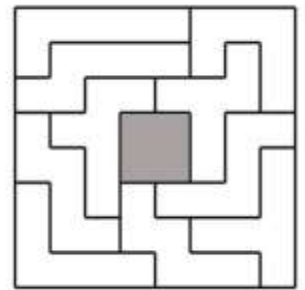
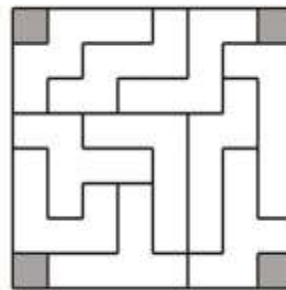

I doubt if many persons have the time and patience to hunt for and find these solutions, so what is the point? Combinatorial puzzles of this sort hold a special fascination for me as a form of mathematical recreation. Every piece effects the location of every other piece. Change just one and everything changes. It has a curious analogy in the profound complexities of our English (or any other) language that we so casually take for granted. In a properly crafted sentence, every word is significant, and has some bearing on every other. According to Robert Frost, this is especially true in poetry, although I have never really understood the distinction between poetry and prose, especially these days.

77. Pieces-of-Eight. The eight dissimilar pieces of *Pieces-of-Eight* plug into each other to construct a cube and many other shapes. One need not be a puzzle expert to enjoy this one. The pieces are fun to just play around with, and I thought they might have educational potential as well. I had hoped that it would be licensed for manufacture but that never happened, at least not yet. In the modified version shown in the photo, two extra half-pieces have been added to fill the square tray and enable additional constructions. The pieces are mahogany, the tray blue mahoe with maple splines.

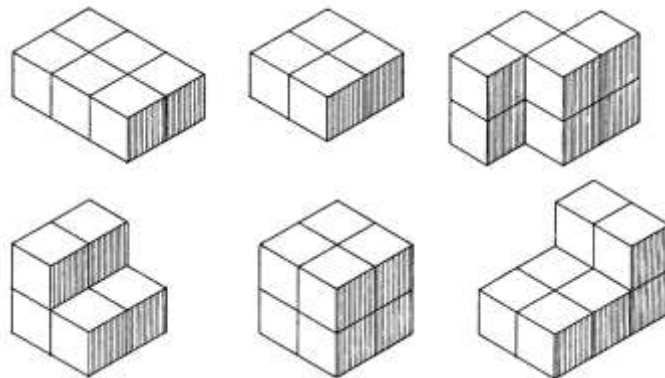
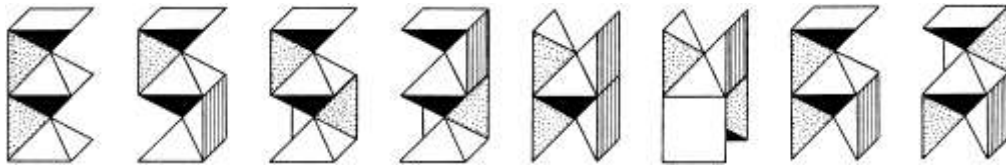

77-A. Pieces-of-Eight, Improved. In this version, extra care is taken for most attractive arrangement of wood grain. In addition I made some with contrasting fancy woods.

78. Pillars of Hercules. It bore a superficial resemblance to an ordinary dissection of the 3x3x3 cube, but two of the pieces were jointed to make four half-pieces. But for all that extra trouble to make, hardly worth it.

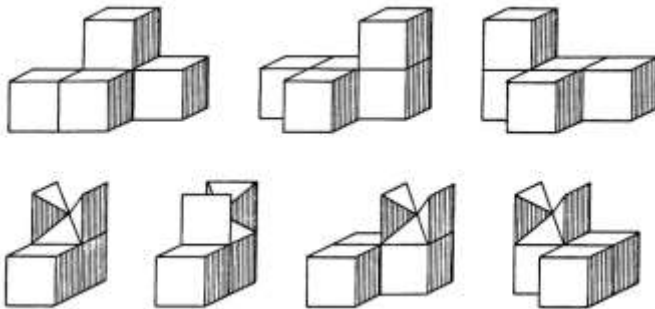

78-A. Yet we keep trying with this variation of the above, but now with three jointed pieces. It did have this one slightly novel feature: If the three pieces are joined together at the start, the puzzle cannot be assembled.

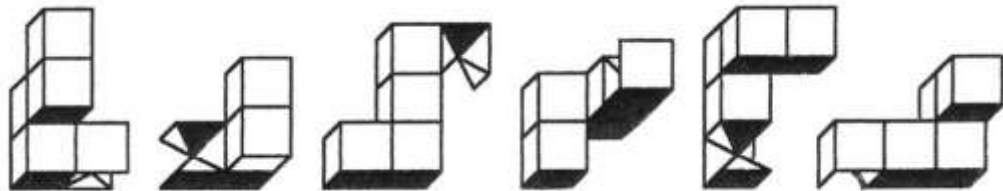

78-B. This was another variation of the above, in which one of the pieces had a swivel joint. The joint used a countersunk screw, with the screw head hidden within a glue joint. The idea was that the jointed piece could be mischievously turned to a wrong shape, and the unsuspecting victim would then seek the cubic 3x3x3 solution in vain. This scheme is not typical of my AP-ART creations, and I can only wonder what accounted for this deviation in 1990. I probably made only one or two of these, and likewise for the others above. But this one, improved, later became an IPP exchange puzzle as *Computer Killer*, #193. In the photo of the pieces, the piece with swivel joint is top right and is shown turned correctly for assembly, with the swivel joint marked in red.

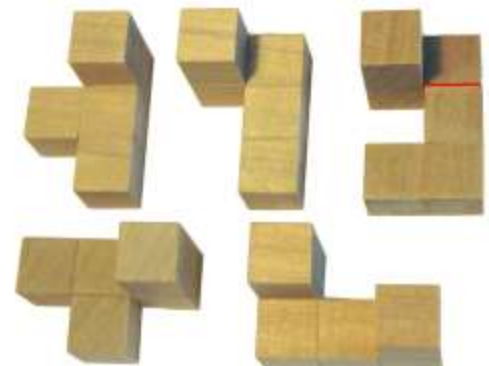
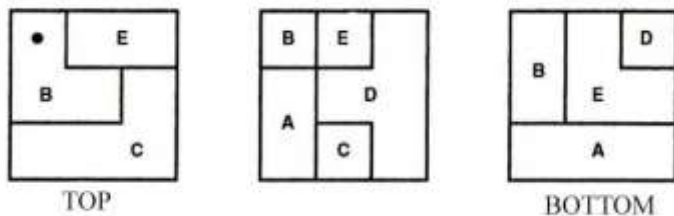

78-C. Five-Piece Solid Block. It is not quite interlocking but nearly so. The model shown is made of one-inch hobby store maple cubes glued with their grains all aligned. Knowing this is an aid to solving, but is actually done to minimize the effects of humidity. The tray is Jamaican quarter-inch sawn veneer of blue mahoe, my favorite wood for this use.

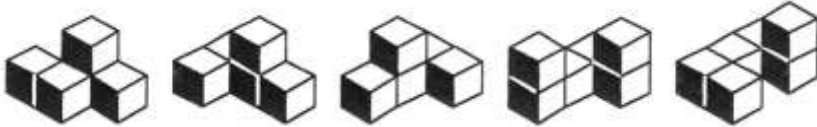
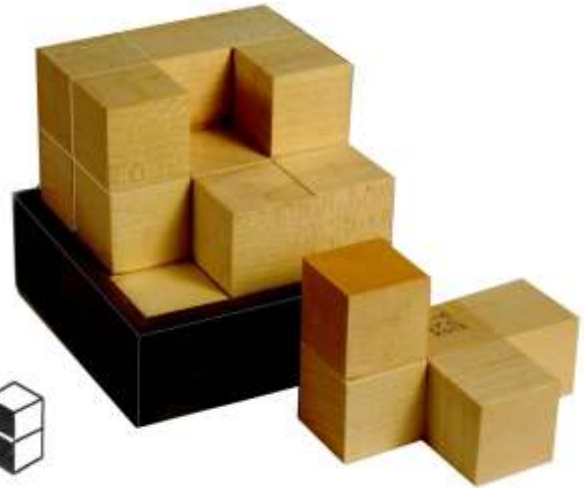

78-D. Pretty Puzzle. This is not just another five piece dissection of the 3x3x3 cube. It rewards the solver with symmetrical patterns of the dissimilar colorful woods on all six faces. Knowing that is an aid to solving. The letters in the drawing indicate the mechanical construction. You can choose your own coloring scheme.

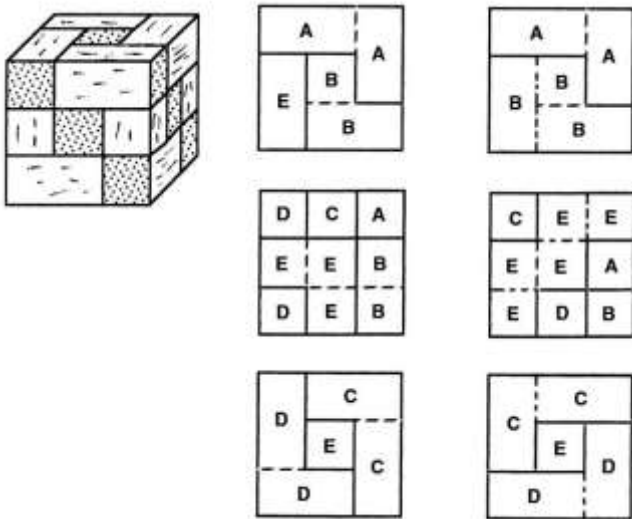

The original design, in the left column, was found to have three solutions. The improved design with only one solution is on the right.

79. Triple Cross and HO HO. The 12 identical pieces of *Triple Cross* or 14 pieces of *HO HO* assemble in the familiar *Square Knot #9* and *Plus 2 #57* configurations but with a completely different type of joint. I made one model in 1973 as a prototype for manufacture in plastic, but of course that never happened. That sample has long since disappeared, so these drawings will have to suffice. It is probably impractical to make these in wood, which is unfortunate because I think this scheme might have much potential as a set of puzzles, a pastime, a construction kit, or an educational toy. Longer pieces with more notches could add to the possibilities. Can you see how the 14-piece version got the name *HO HO*?

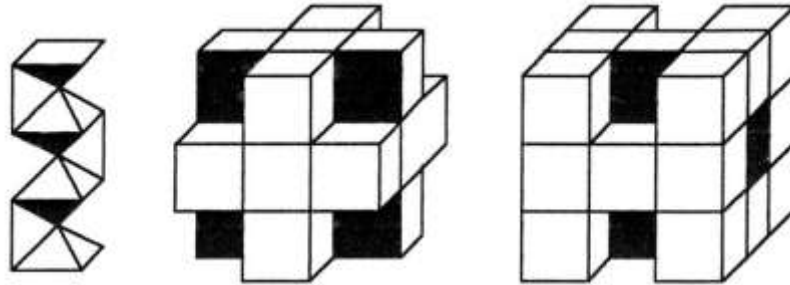

After writing the above, I wondered what far corner of the world my model might have ended up in. It turned out to be a far corner of my basement workshop. So here it is. The writing on the side reads: HO-HO, #79, STC, ©1973. We often see plastic colored to simulate wood, but here again is wood painted to simulate plastic.

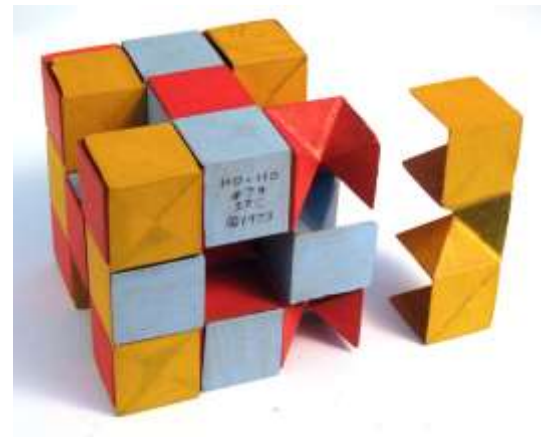

And now yet another one turns up, this one sent to me recently by Steve Nicholls and printed by him in ABS plastic. It fits with a degree of precision that I can't imagine achieving in wood.

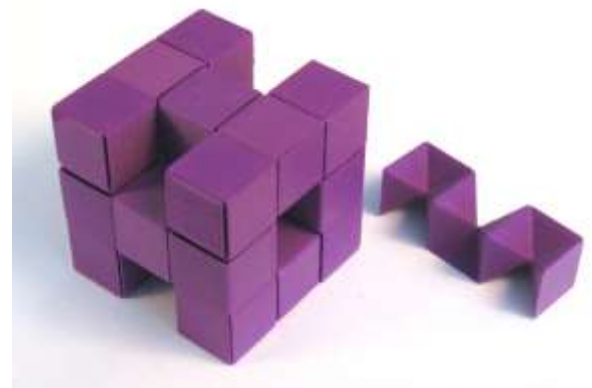

80. Thirty Pinned Pentagonal Sticks. My rules for optimum puzzle design call for few pieces, all dissimilar and non-symmetrical. But here in *Thirty Pinned Pentagonal Sticks* we have 30 identical bars and thirty identical pins, all symmetrical. What's going on? This is not a puzzle. With the illustration to go by, it is a fascinating and not difficult assembly exercise that rewards the maker with an intriguing sculpture in fine wood. For further amusement, when completed you can try counting the axes of symmetry. Hint: stop when you reach 31.

This design was revived in 2013 and listed as *Pentacage #M-4* (see Part 4).



80-A. Thirty Pentagonal Sticks. A Five-hole version, no photo. I made only one experimental model in 1988, but this too was revived in 2013 as *Pentacage #M-3*.

80-B. Thirty Pentagonal Sticks. Three-hole version, no photo. I likewise made only one experimental model in 1988, but now also revived and re-listed as *Pentacage #M-2*.

81. Nest Construction Set. This idea was a box full of drilled hexagonal bars and round pins of assorted lengths to be enjoyed by those who like to explore and discover, but it never went anywhere.



81-A. Two-Three. Here is an example of wonders to be discovered using the construction set mentioned above. The three hexagonal sticks and three pins of *Two-Three* assemble easily into a triangular configuration as shown. For added amusement, an even simpler solution uses only two sticks and two pins, not shown but use your imagination. Or join some of the parts to make elbow pieces.



81-B-1. Four-Legged Stand. Another example of discovery using my proposed construction set. This simple puzzle is made of four hexagonal sticks and four pins. Two of the pins can be fastened to make one elbow piece and one cross piece. Easy to make and easy to solve.



81-C-1. Double Four-Legged Stand. With the drill jig all set up for *Four-Legged Stand*, and with surplus hexagonal birch stock, it made sense to exploit the situation with other projects. *Double Four-Legged Stand*, as you might guess if you can't count them in the photo, has double the number of sticks and pins. Each stick has four holes, but they are different from those in the *Nest Construction Set*. Can you spot the difference in the photo? In the construction set the first and fourth holes are mutually parallel, but in *Double Four-Legged Stand* the first and third holes are mutually parallel. My version of this puzzle uses four elbow pieces. But which kind? As shown below, there are two kinds of elbow pieces. Or we might have used T pieces instead, and there are two kinds of those too. Oh so many possible combinations. No wonder this relatively new branch of mathematical recreations is so fascinating. Life is too short to explore for all of these buried treasures, so one must pick and chose. Or do it my way and just meander randomly about.



My version uses four identical elbow pieces L, on the left above.

To assemble:

Insert L1 into bars B1 and B2, taking care that there is a right and wrong way for the bars to be positioned.

Insert L2 into L1 and B1.

Place B3 into L2.

Place B4 into L1.

Insert L3 into B4, B3, and B1.

Insert L4 into L3, B4, and B2.

Insert the four pins to complete the assembly.



82. Patio Block. The idea for this one came to me from a publication by Rik van Grol and from a similar design by Kevin Holmes. Here is a great opportunity for recreation that demands very little shop work. Start by joining 1x2x2 blocks all ten possible ways. Now put aside the two that are rectangular solids. Try fitting the other eight into a 4x4x4 box until you become convinced that it is impossible. Try eliminating one and duplicating another until they not only fit but do so with interesting symmetry. I purposely omit the design so that readers may have the pleasure of rediscovering it, the pieces are so easy to make and so much fun to play with. An IPP exchange.

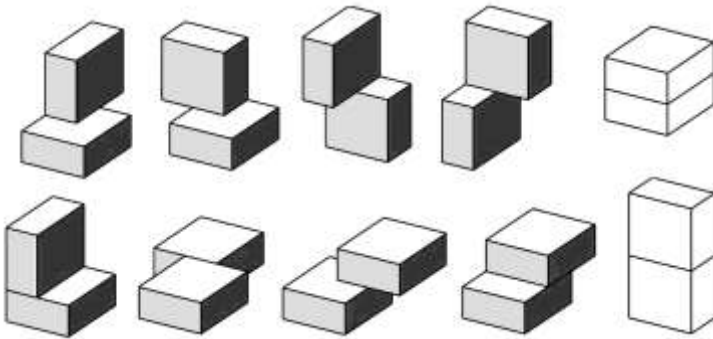

In editing, I have decided, why be so coy? In my version the zigzag piece on lower right is the one that is duplicated, and the two-step piece just to the left of it is omitted. But evidently I have not saved my design notes, so I do not now know if this is necessarily the only way, or if other possibilities exist. So here is another opportunity for investigation in recreational mathematics. And of course play around also with the full set of ten pieces.

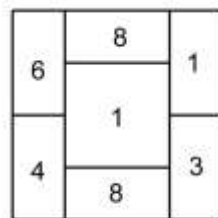

TOP LAYER

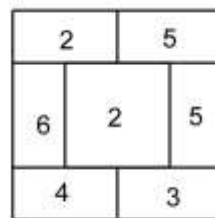

BOTTOM LAYER

83 and 83-A. Pentagonal Stand. With *Four-Legged Stand* already done, of course we need one with five legs. Not only is *Pentagonal Stand* made with the same setup as *Thirty Pinned Pentagonal Sticks* #80, if you were to examine the two closely, you would see that *Thirty Pentagonal Sticks* could visually be dissected into twelve *Pentagonal Stands*. To make *Pentagonal Stand* into a simple puzzle instead of just a novelty, in the 83-A version two of the pins are attached to make elbow pieces. Instead of just gluing the pins in place, I prefer to secure them with 1/8-inch plugs, as can be seen in the photo.



84. Obstructed Pins. Quoting from my 1990 design notes: “12 hexagonal sticks of 3 holes each and 12 dowels; 3 of the sticks are slightly shorter on one end, allowing 3 dowels to be removed.” This would appear to be the same as the not very satisfactory #22-A. Can’t explain the apparent duplication. You may be able to see in the photo that the final few pins can’t be inserted unless some extra clearance is provided. This model is in Australian lacewood.



More recently I have made this reconstruction in poplar with three of the ends notched rather than shortened. One of the rounded notches is faintly visible at lower right. I think this is the more satisfactory version.

84-A. Eighty-Four. I also made an experimental variation of *Obstructed Pins* with 30 pentagonal sticks and 30 dowels. I believe it is now in the Slocum collection. For larger photo, see the nearly identical symmetrical version *Three-Hole Pentacage* #M-2 in Part 4.

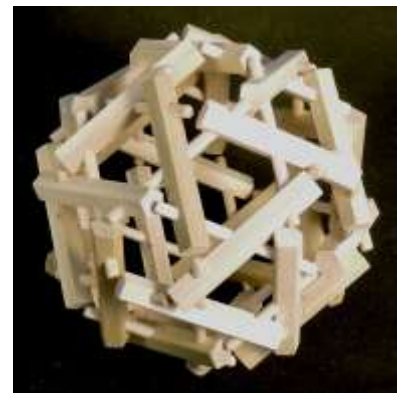

85. Twelve-Piece Separation. Here is another one of those rare examples where Mother Nature cooperates marvelously with the occasionally lucky puzzle designer. Visualize this puzzle as 12 triangular sticks with triangular blocks attached at both ends of each, locking it solidly together. To permit at least the first step of disassembly, remove one block, thus creating a key piece, and attach that block to an adjacent piece. Can the resulting arrangement be disassembled? Yes, surprisingly, and still more amazing, in essentially only one tricky order, making it possibly unique among all known (or even possible) puzzles with so many identical pieces. Certainly one of my very luckiest discoveries, and easier to make than most. Typically the puzzle designer goes to great pains to achieve all these features, but here they just occur naturally. My model is Honduras mahogany, an excellent wood for making puzzles of this sort, and incidentally one of the best for photography.

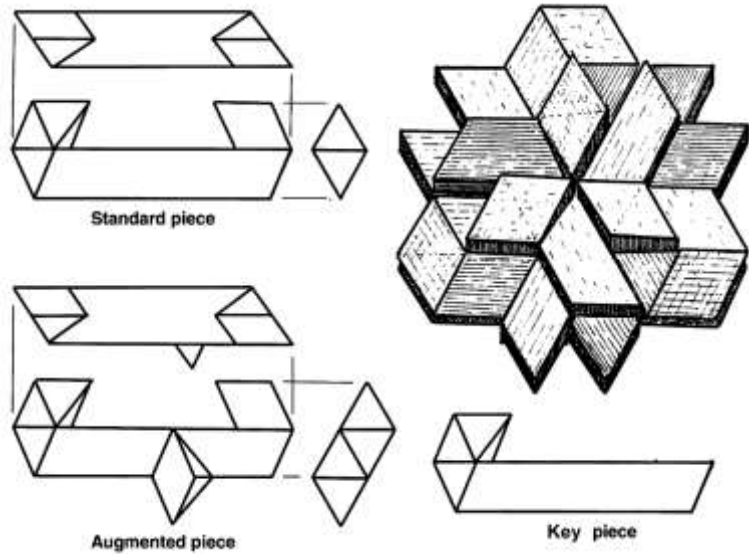

Assembly directions for puzzle #85, the
TWELVE-PIECE SEPARATION.

Pieces are numbered in order of assembly.
All figures are looking straight down from
the top.

1. Assemble three pieces as shown in
Fig. 1 to form a triangular base.

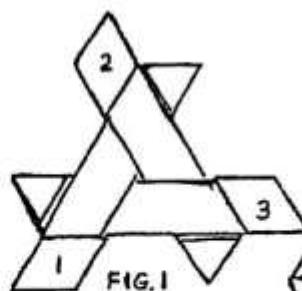

2. Insert piece 4 vertically, hook
augmented piece 5 around it, and then
insert piece 6 vertically from below,
as shown in Fig. 2.

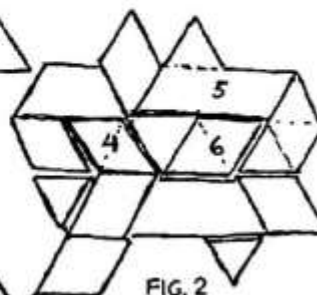

3. Push piece 1 inward all the way and
piece 3 one inch to the right in order
to insert piece 7, as shown in Fig. 3.
Return piece 3 and then piece 1 to their
previous locations.

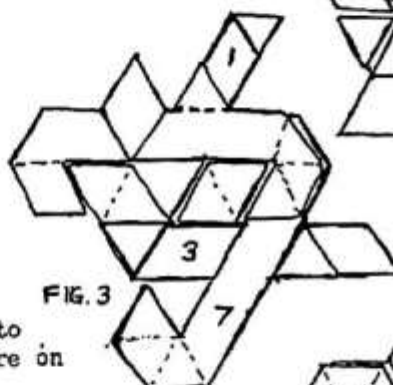

4. Install piece 8 from the left, as
shown in Fig. 4. These first four steps
will require some dexterity and patience to
hold all the pieces in place, but from here on
it gets easier.

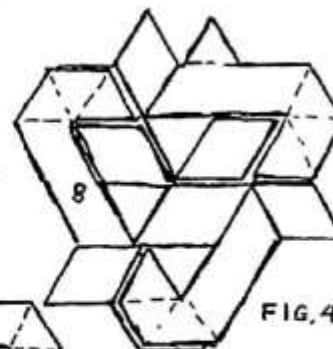

5. Drop piece 4 down, push piece 7 in, and slide piece 8
one inch to the right in order to install piece 9 vertically.
With piece 9 dropped all the way down, return piece 7, then
piece 8, and raise all vertical pieces into
position, as shown in Fig. 5

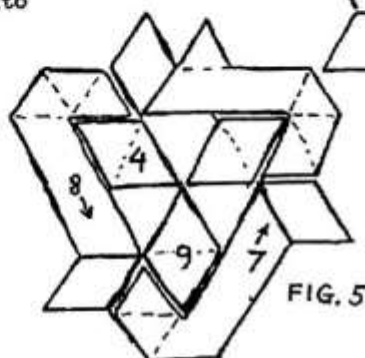

6. Piece 10 is directly installed
from the left, as shown in Fig. 6.

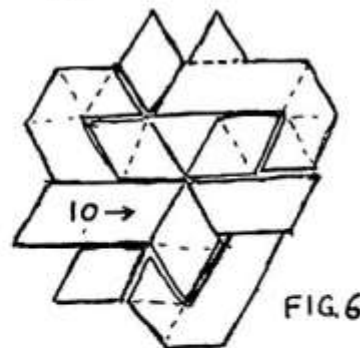

7. Now the tricky step. Drop pieces
4 and 6 down, slide piece 8 far to the
lower right, then piece 10 one inch to
the right in order to insert piece 11,
as shown in Fig. 7. Return piece 10
left, raise piece 6, slide piece 11 into
place, return piece 8, and raise piece 4
into place.

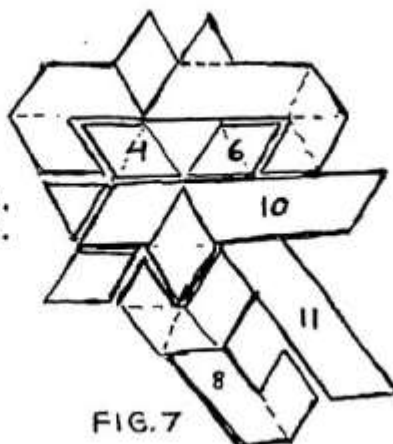

8. Insert key piece 12 to
complete the assembly.

Disassembly follows this
procedure in reverse at least
until pieces 8 and 9 are removed.
Minor variations may be possible.

S.T.C.
JAN. 1990

85-A. Geodynamics. Designing and making *Geodynamics* was an exercise in both math and woodworking. The *Twelve-Piece Separation* has here been distorted by expansion along one orthogonal axis and compressed along another, as in going from cubic to brick shaped. Calculating all the angles was an absorbing recreation in solid geometry and trigonometry. Sawing them out required the painstaking construction of many special saw jigs, which took up so much space in my workshop that I discarded them after making only a few puzzles. Notice anything unusual about the invented name *Geodynamics*? No letter is repeated. Thus each piece after the key can be assigned a letter for ease of following the assembly instructions (next page) that came with it, without which it would be woefully difficult except perhaps for a few die-hard experts.



Added note: What is the point, you may ask, of designing a puzzle so difficult to solve that few will manage to do it unless given the complicated directions? And so difficult to make that I made only a few? The answer is simple enough: I had fun designing it, making it, and working out the assembly instructions. Even including the name. I have used the same instruction sheet drawing for both versions, merely changing the numbers to letters.

Assembly Directions for Puzzle #85A, GEODYNAMICS.

Pieces are lettered GEODYNAMICS in order of assembly. All figures are looking straight down from the top.

1. Assemble three pieces as shown in Fig. 1 to form a triangular base.

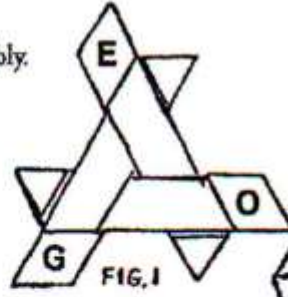

2. Insert piece D vertically, hook augmented piece Y around it and then insert piece N vertically from below as shown in Fig. 2.

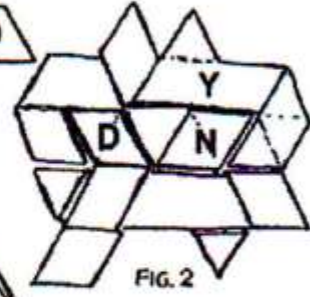

3. Push piece G inward all the way and piece O one inch to the right in order to insert piece A as shown in Fig. 3. Return piece O and then piece G to their previous locations.

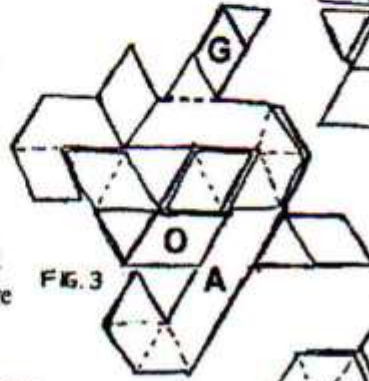

4. Install piece M from the left as shown in Fig. 4. These first four steps will require some dexterity and patience to hold all the pieces in place, but from here on it gets easier.



5. Drop piece D down, push piece A in, and slide piece M one inch to the right in order to install piece I vertically. With piece I dropped all the way down, return piece A, then piece M and raise all vertical pieces into position as shown in Fig. 5.

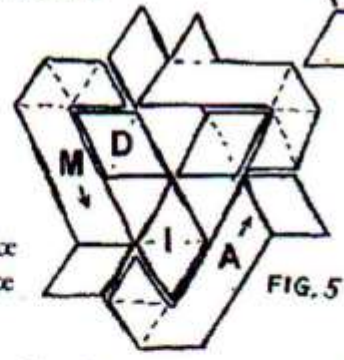

6. Piece C is directly installed from the left, as shown in Fig. 6.

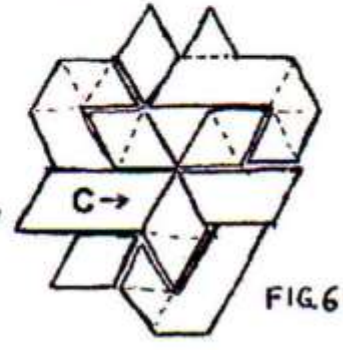

7. Now the tricky step. Drop pieces D and N down, slide piece M far to the lower right, then piece C one inch to the right in order to insert piece S as shown in Fig. 7. Return piece C left, raise piece N, slide piece S into place, return piece M and raise piece D into place.



8. Insert key piece to complete the assembly.

Disassembly follows this procedure in reverse at least until pieces M and I are removed. Minor variations may be possible.

S.T.C.
JAN. 1990

86. Four-Piece Separation. This is a derivative of the 12-piece version. It has four-fold symmetry and a sliding key piece. See also *Arm-in-Arm* #190.

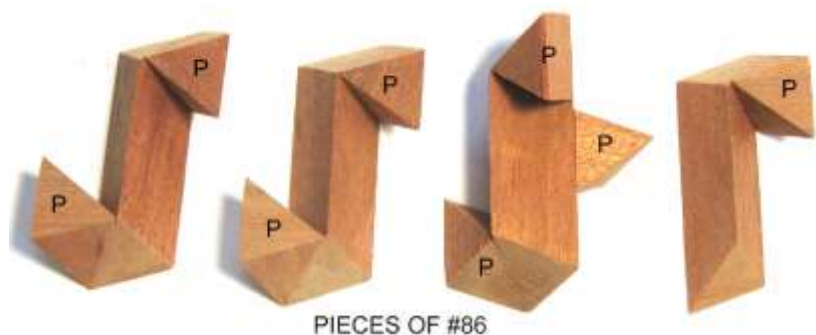

86-A. Three-Piece Separation. The identical pieces of *Three-Piece Separation* lock lovingly together in each other's arms with twisting coordinate motion. Perhaps too simple to be much of a puzzle, yet even it has recreational potential. It awaits some mathematical genius to determine if the mechanical action of my version is geometrically proper, or whether some slight looseness is required. Or even more to the point, determine the correct isosceles triangle cross-section of the sticks for perfect interlock. My version has sticks of equilateral triangle cross-section, which I am guessing is the correct angle or very close to it.



To demonstrate the point about correct cross-section, as well as to remove any lingering doubts I might have had about it, I made this model with isosceles right triangle cross-section sticks, and glued together the pieces while assembled. They are locked tightly together with no possibility of being disassembled.

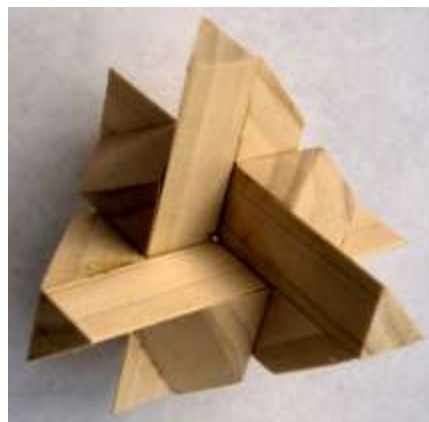

87. Two-Sided Tray. This five-piece dissection puzzle came with a two-sided tray, square on one side and rectangular on the other, and with seven problem shapes to be solved.

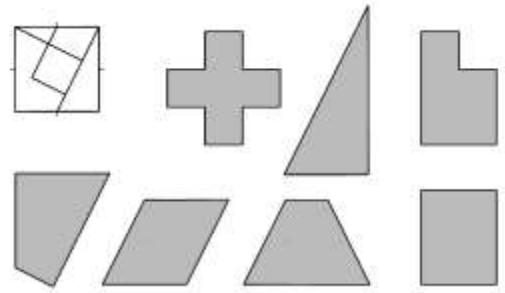

Too simple? But there is more. Now find a way of dividing one of the pieces in two such that these six more problem shapes can be constructed. It is obvious which piece to divide, but which way? (Pardon the digression, for this and the next are more problems in recreational math rather than practical woodcraft. But still to be enjoyed, nevertheless.)

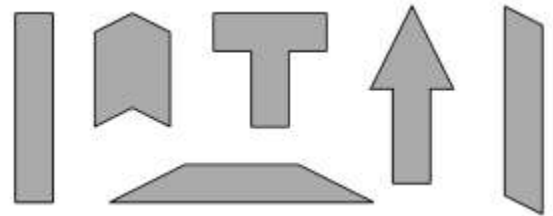

87-A. Quadrilateral. The only existing copy of the original version of this puzzle was lost at an exhibit in Atlanta before I recorded the design, so this is the reinvented version, which may or may not be the same. It was intended to come with the 28 problem shapes shown below, rather like the popular *Tangram*. It is more fully described in my *Puzzle Craft 1992*. For a long time I had hopes that this puzzle might be manufactured and sold in a box with the problem shapes outlined full scale on separate cards. Those too long to fit in the box could be folded. But it never happened, and I have no record of making and selling any myself.

This puzzle is likewise fairly easy for anyone to make in wood or whatever, as described for the previous design. For maximum enjoyment, draw all the problem shapes on card stock full-scale. Note the slight but important differences between some of the problem shapes, indicating that care must be taken in both cutting out the pieces and outlining the problem shapes. I believe this is the complete set of possible quadrilateral solutions, but for added recreation see if I missed any.

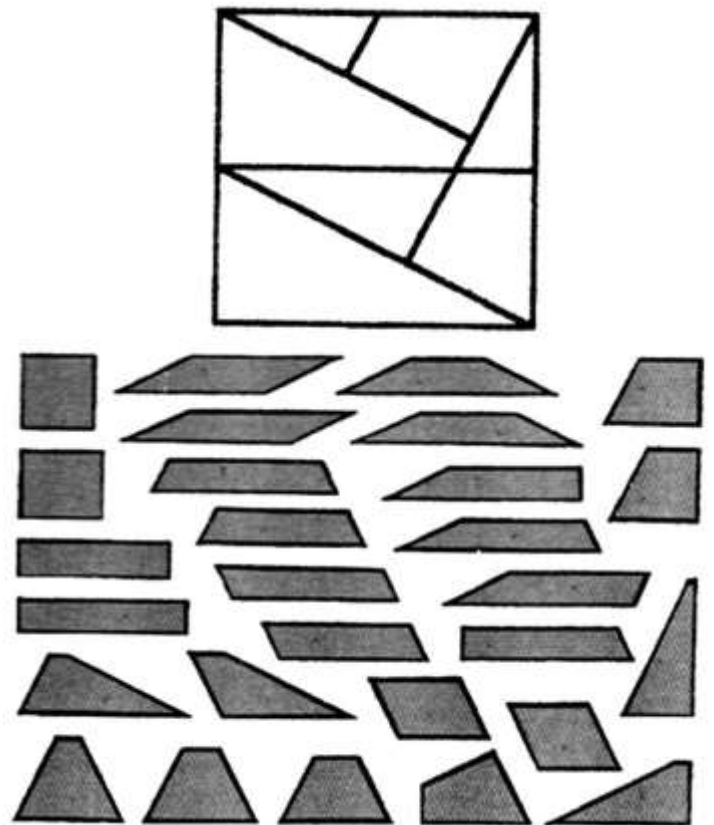

I have heard that *Quadrilateral* was produced for a while by Trench Enterprises in England.

88. Little Rocket. Now I can tell: The six colorful pieces of *Little Rocket* were made of scrap tetrahedral blocks left over from other projects. They were of such nice woods I hated to just throw them away. Hence the ten that I made around 1989 were probably all slightly different. They assembled inside a squarish launching pad to form a rhombic dodecahedron. I believe I gave some of them away rather than sell them, and I was surprised when I started getting requests for them. But I soon used up all the scrap blocks, and don't believe I made more than just those ten. In keeping with the whimsical origin, I also made the launching pads from scraps, so no two were quite alike.

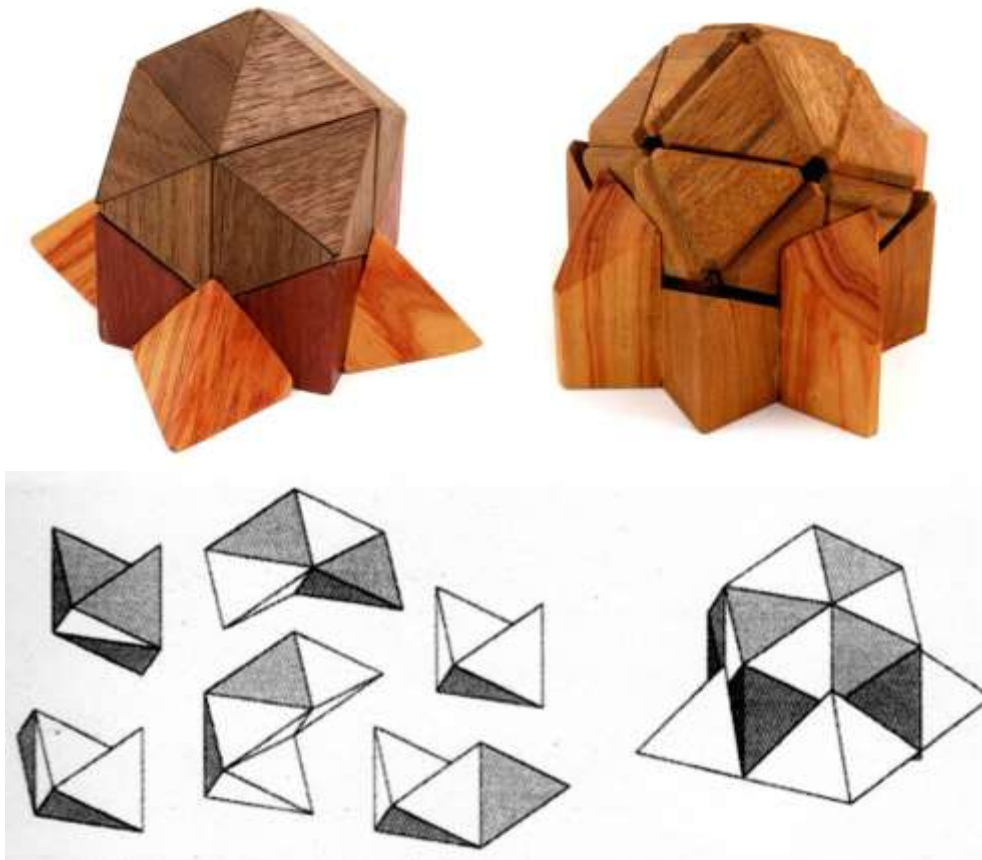

These tetrahedral blocks are the same as those used in making *Sirius #4*, plus many others, and are described more fully in the Appendix.

90. Permuted Four Corners. I made two of these in 1990 and sold both to collectors now deceased. Unfortunately I failed to keep any design notes. Until quite recently I considered it a lost design, but now, thanks to some diligent searching by James Dalgety in England, come these two photos. The foundation of each of the six pieces is a standard six-sided center block. Attached at both ends are tetrahedral blocks, here in lighter-colored oak. In other words, your basic *Sirius* #4 construction. Then 12 rhombic pyramid blocks are added (shown here in darker wood) to create six dissimilar non-symmetrical pieces with only one solution.

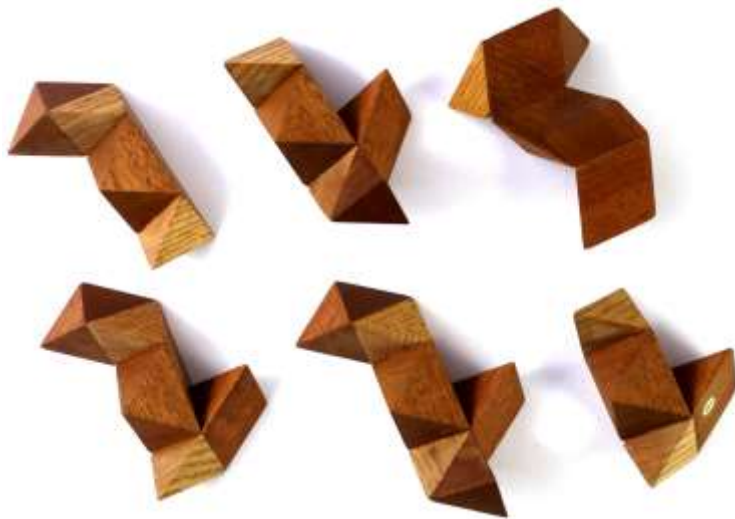
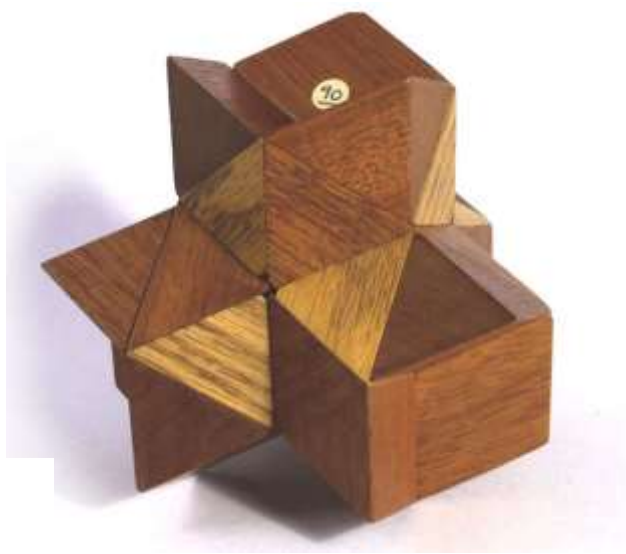

92. Queer Gear. The six dissimilar pieces of *Queer Gear* assemble by mating two halves along a surprising diagonal axis to form a Star of David prism. The two end faces lend themselves to being sanded and polished to bring out the natural beauty of the wood. Note the mirror-image symmetry of the three pairs of pieces. This reproduction is by Mark McCallum.

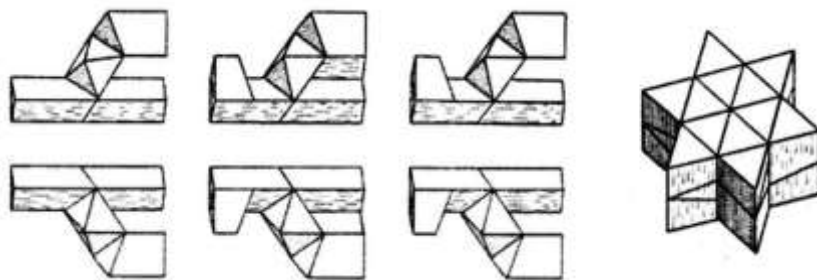

92-A. Second Gear. We shift into *Second Gear* by compressing *Queer Gear* (which I now wish I had called *First Gear*) by 22% along its vertical axis. These more complicated saw cuts are by now becoming fairly routine. In the model shown, I used four different colorful woods arranged symmetrically.

I may have made only this one. I don't know where it is now, nor do I recall who furnished the photo. Thus, unfortunately I am unable to show what the pieces look like until I can discover where it is. But the pieces are not all that different from #92, just different angles.



93. Four-Piece Serially Interlocking Cube. Now, more than sixty years after fashioning the *Mikusiński Cube* from wood scraps, dissections of the 3x3x3 cube continue to fascinate me, but especially those that interlock. Better still, with all dissimilar non-symmetrical pieces. Is such a five-piece version possible? I doubt it, after having searched for years. Perhaps some curious math whiz will come up with an impossibility proof, and perhaps using a computer. I have designed several that come close, but most use a piece or two that is symmetrical, such as a single block key. A four-piece version that satisfies all of these requirements can also be entertaining. Here is one. How many others are possible? Why not explore on your own with hobby store cubes. Children might find recreations like this both enjoyable and educational. Accordingly I omit design details, but the photo with multi-colored pieces gives clues.



As already mentioned in connection with *Convolution* #30, I purposely refrain from publishing some of my design notes, such as those for interlocking dissections of the 3x3x3 or 4x4x4 cube. Let others also have the pleasure of seeking and discovering. By the same token, I feel that some other mathematical recreations of this nature are perhaps better left unpublished (although this *Compendium* may strike some as a glaring contradiction). I have somewhat softened my notions about this in recent years, and this *Compendium* contains several solutions and design details not previously published.

What could I have been thinking when I wrote that in 2014? Here is the plan, but I still think you might have more fun coming up with a new and original design of your very own.

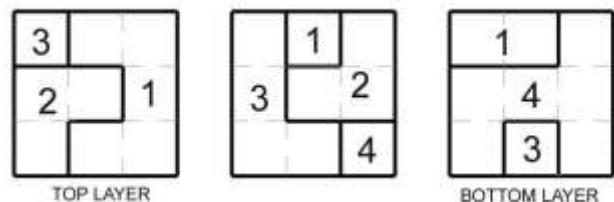

94. Fourth

Dimension. This is a simple derivative of *Pennydoodle* #67-B. The four pieces, two of each kind, assemble with coordinate motion to form either a square or tetrahedral shape. They have to be made quite accurately to slide smoothly together and apart. I made only four in 1991, here in oak.

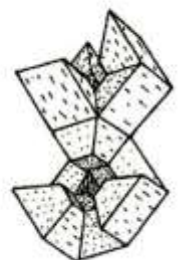
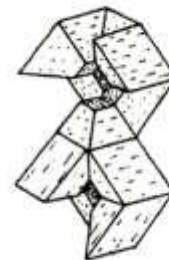
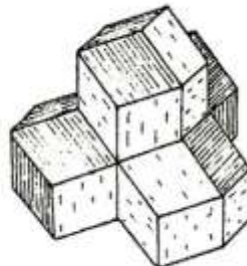
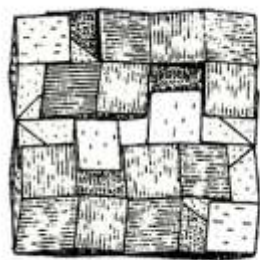

95. All Star. This is a sequel to *Star of David* #37, and even more versatile. The six dissimilar pieces can form three interlocking and elegantly stellated sculptures with three-fold symmetry, plus two more with bilateral symmetry. Two dissimilar woods are used, and all solutions will automatically appear with color symmetry. I consider it my best design in the category of being able to form multiple shapes. Three pieces are shown, and the other three are their mirror images. A description of the universal building blocks is in the Appendix.

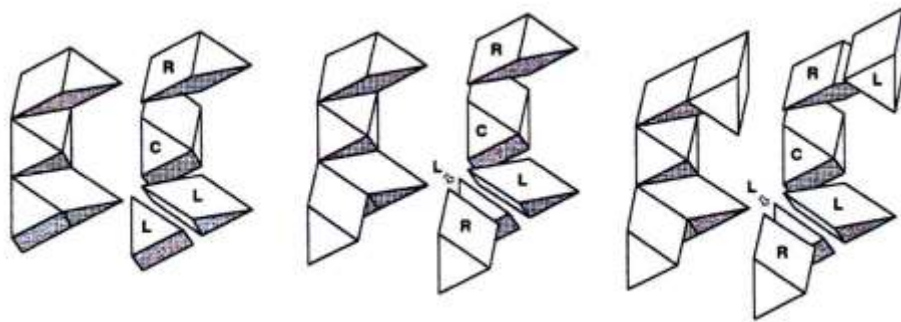
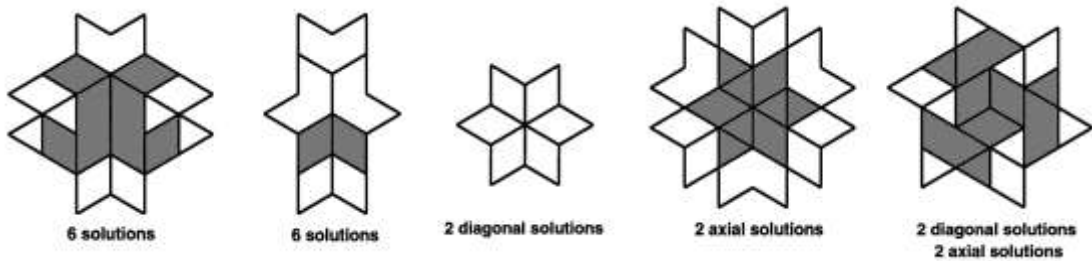

96. Teddy Burr. This is the first in a series of six mischievous distortions of the familiar standard six-piece burr. It is the easiest to explain and probably the easiest to make. The standard six-piece burr, in its simplest form, consists of six identical notched square sticks, except that one has an extra center notch that is necessary to permit assembly and disassembly. In *Teddy*, the cross-section of the sticks is rhombic rather than square. The degree of deviation from square is arbitrary. I have used about 6 degrees. Less than that, there is a tendency to try forcing together the wrong way. Much more than that and it starts to lose its identity as a familiar burr, as well as being harder to make. For the hobbyist, the notches are usually made with multiple saw cuts.



Teddy comes in two varieties, squat and upright, for an explanation of which see Design #68. Both have one three-fold axis of symmetry. When viewed along this axis, both look the same. When viewed perpendicular to this axis, as in this photo, perhaps the squat form becomes apparent. There are two kinds of pieces, three of each, that are mirror image of each other, except for one having that required extra notch.



96-A. Grizzly Burr. In *Grizzly*, all three pairs of square sticks are rotated along their longitudinal axis, by about six degrees in this example, creating much confusion. The pieces are numbered 1 to 6, left to right. In this version, pieces 1 and 2 are identical, likewise pieces 3 and 4, which are mirror image of piece 1 and 2. Pieces 5 and 6 would be mirror image except for that necessary extra notch in piece 6. Many other combinations are possible. Perhaps it can be seen that all notches are on a 6-degree slant, left to right. Although not shown so clearly in the photo, the notches are also tapered by 6 degrees front to back. Rather than relying on the enhanced photo to make copies, I think the better approach in this case is to start from geometric principles and use logic. And be prepared to have fun making a few mistakes along the way, as did I.



96-B. Double Notch. My original design notes, if they ever existed, have been lost, and no model was ever saved. This description is based on photo and notes sent to me by Nick Baxter, and my reconstruction may differ slightly from the original. In this new model, made with 0.750-inch square sticks, the wide notches are 1.500 wide, and they all slope by 5 degrees both side to side and front to back. But when viewed from above, they are cut at right angle to the axis of the stick. This results in two sets of three that are mirror image: 1-3-5 and 2-4-6. But pieces 3 and 4 each have an additional center notch. The notch on piece 3 is deep, but on piece 4 is shallow. This design has a mathematical imperfection in that these center notches must be about 0.775 wide instead of 0.750. Also, the pieces must not be over 2.95 long. To disassemble, piece 3 shifts down, allowing piece 5 to slide to the right just enough to release piece 3. This is why the pieces can't be too long.

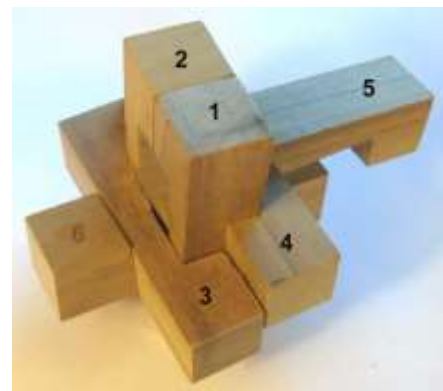

97. Crooked Notches. This is a variation of the familiar six-piece diagonal burr, but here compressed along a three-fold axis, making the sticks rectangular cross-section rather than square, and the notches crooked. I made 100 of these of southern yellow pine for the 1994 IPP puzzle exchange. It looks simple enough. Two identical V-shaped notches in each piece. Two kinds of pieces, three of each. It is assembled by mating two subassemblies that are mirror images. But recently, when I attempted to make one to round out my collection, I found it too taxing to easily achieve the required accuracy in the saw cuts for the notches in my makeshift workshop and gave up.

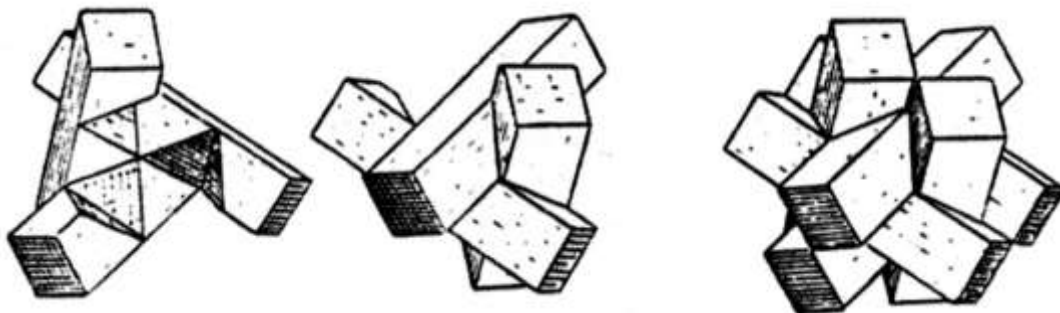

97-A. Rectangular Faces. Evidently I made a couple of these in 1994 but did not record design details. Here is a photo and quote from the John Rausch website, <http://www.johnrausch.com/puzzleworld>: “Both of these *Rectangular Faces* puzzles are distorted versions of the *Square Face* puzzle (my #74). The one in the bottom photograph (the one shown here) is doubly distorted! Though resembling the *Three Pairs* puzzle, the construction is entirely different. Stewart made 2 of the one in the ... photograph and 1 of the other in 1994. Numbers 97-A and 97-X in his numbering system.”



98. Yogi Burr. It is more confusing than the others it resembles because of the bizarre combination of slant and skew of the notches in the square sticks. After having designed and made several of these strange burrs with crooked notches, I have to wonder how much fun friends really have trying to solve them. I am guessing probably not very much. The real fun is in designing them and then figuring out how to make them. Laboring over how best to describe some of them in this *Compendium* is not quite so much fun. I’ve done the best I can with the illustrations below. The angles in the graphic are greatly exaggerated for clarity, as my usual deviation from orthogonal is about six degrees.

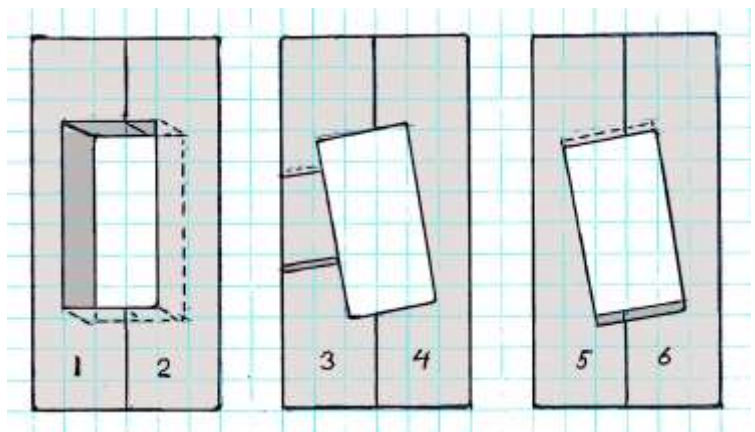

98-A. Slant Six. This one combines the devious complications of the other three above that it resembles. I produced a limited edition of these in 1994 using $\frac{3}{4}$ -inch padauk, a choice wood selected for its attractiveness, good workability, and excellent stability. The more recently made one is in poplar. Pieces 1-3-5 are identical and pieces 2-4-6 are their mirror image, except that piece 3 has that extra center notch. In the first step of disassembly, piece 2 slides to the right, releasing piece 3.

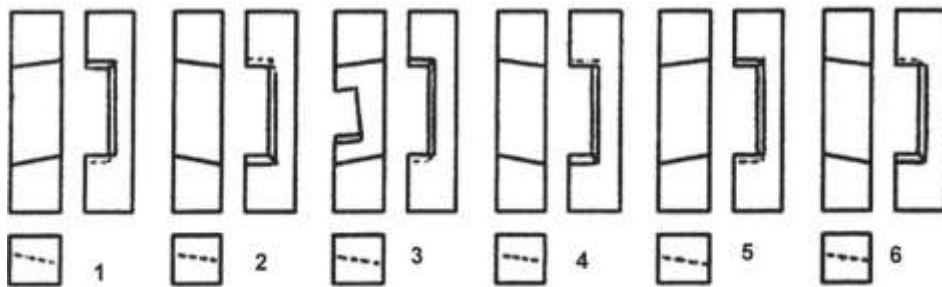
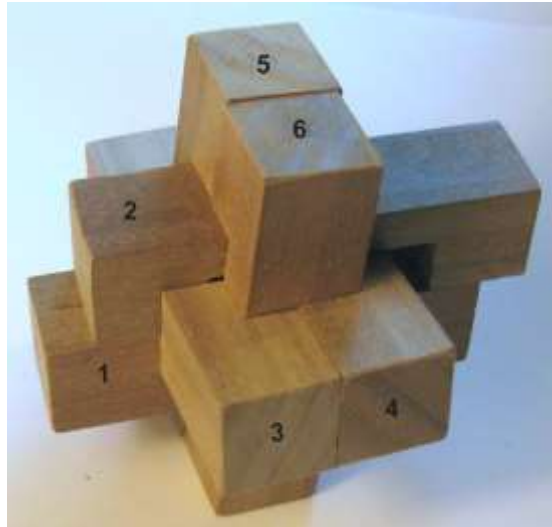

99. Disinclination. It can be visualized as *Seven Woods* #42 that has been distorted by compression along a threefold axis, making the faces rectangular rather than square and changing all the angles. For me it was just another exercise of playing around in my workshop. By this time I was getting pretty good at making these sorts of things, aided by several specialized saw jigs, which were in themselves also fun to design and make. But they took up a lot of space and I no longer have any of them.

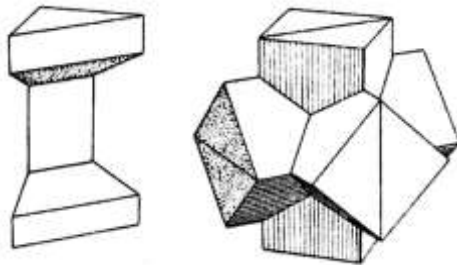

100. Concentrix. This one has an interesting history. Back in my plastic puzzle phase of the early 1970s, I was playing around with a styrene *Hectix* one day, curious to see if I could make the assembled shape more polyhedral by plastic surgery. I was pleased with the one model I came up with and must have kept it for a while to admire, but then it vanished, probably into someone's collection. Around 1994 I had a notion to resurrect the design, and I gave it a name and number. But alas, I had either forgotten the design details or never got around to making one. And now, twenty more years later, I try again and this time succeed, although I would hate to say how much wood I wasted before I hit upon the correct shape. What helped was having a photo of *Meteor* #100-A, which has the same angles. One consideration in making *Concentrix* is that some edges of the pieces are prone to breakage unless a strong wood is used. This one is red oak. It might be a good puzzle to mold in plastic as a sequel to *Hectix*.



In the order shown, left to right, the puzzle uses seven standard pieces, three skinny pieces, one augmented piece, and one key piece.

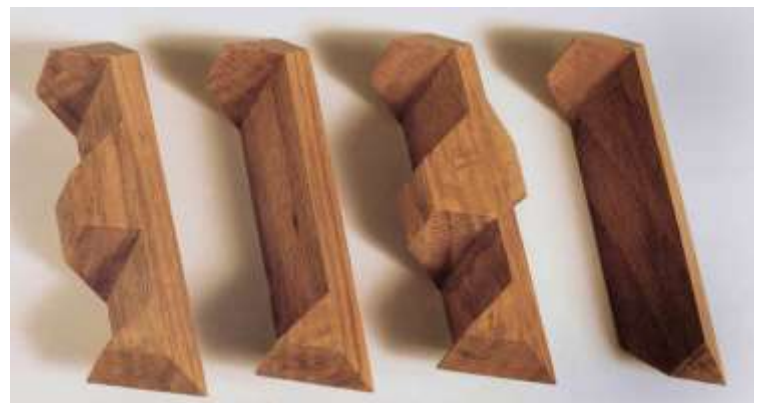

100-A. Meteor. Although you might not guess it from casual inspection, *Meteor* is, like *Concentrix*, a variation of *Hectix* #25, modified by changing the shape of the ends of the pieces plus internal changes to create a key piece. One must wonder what other sculptural variations such as this may be possible. I believe I made only one crude model in pine, but it was sufficient to inspire other woodworkers. This one shown was expertly crafted by Bart Buie.



The 12 pieces follow the same plan as for *Concentrix* #100 – seven standard pieces, three pieces with skinny center section, one augmented piece, and one key piece. Only the standard piece is shown below, and a *Concentrix* piece is shown below it for comparison.

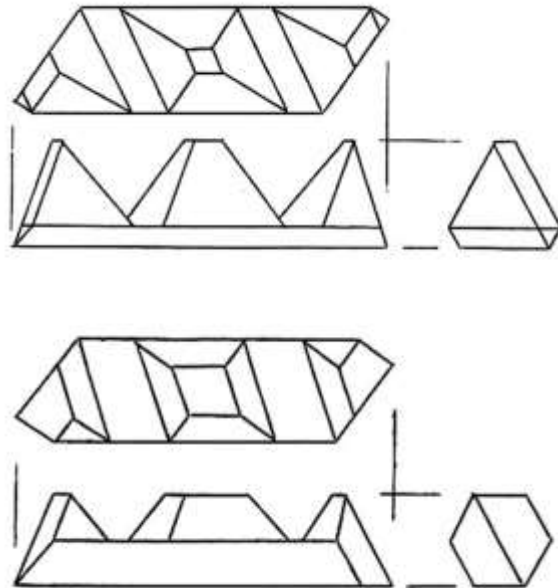

101. Isosceles. This is a distorted variation of a 12 piece construction that is in turn a variation of *Twelve-Piece Separation*. The distortion is by compression along one of the four-fold axes of symmetry. I include it here, not as a practical puzzle design (it is woefully difficult to make *and* assemble) but as a specimen of whimsical woodcraft. One redeeming feature for the intrepid woodworker who may wish to give a try is that all sticks have the same 50-65-65-degree cross-section.

The pieces are made of triangular sticks with triangular stick segments attached at both ends, except for the three mutually parallel key pieces that are plain on one end, marked **K** in the photo, with their missing segments, outlined and marked **A**, attached to adjacent pieces.



101-A. Iso-Prism. This is a companion to *Isosceles* and even more complicated, in which 24 more triangular stick segments are added to the empty spaces in *Isosceles* to create an intriguing sculpture with eight isosceles triangle faces. I crafted both of the camphorwood models shown mostly just to demonstrate that it could be done.

The drawings are top and bottom views, showing how the added blocks are attached. The three key pieces are marked **K**.

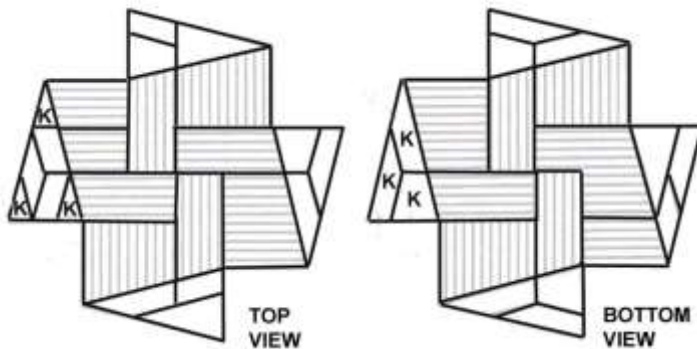

Added note: James Dalgety reports finding a second solution in which the key pieces are not mutually parallel.

102. Incongruous. This is another unusual variation of the six-piece diagonal burr (see *Pseudo-Notched Sticks* #63) in which the sticks have rhombic cross-section and require coordinate motion to assemble. The top piece in the drawing has the extra notch and is coaxed in last. The angle of the cross-section of the pieces is critical and is calculated by vector analysis to be 76.9 degrees, but 77 degrees is close enough. An IPP exchange.

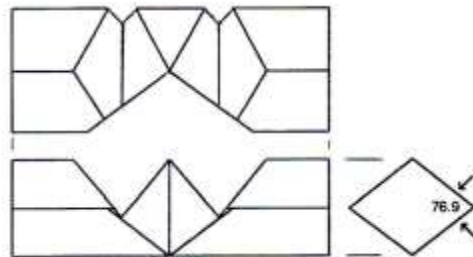
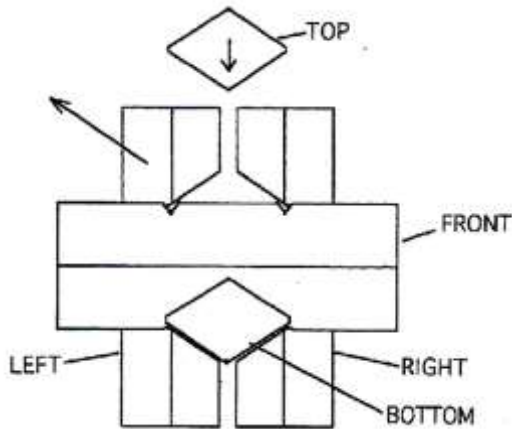

102-A. Redemption. This one has the same assembled shape as *Incongruous* #102, but has two pieces with an extra notch cut at an odd angle, making it even more difficult to assemble. I made only one experimental model, just for fun. Same photo serves for both.

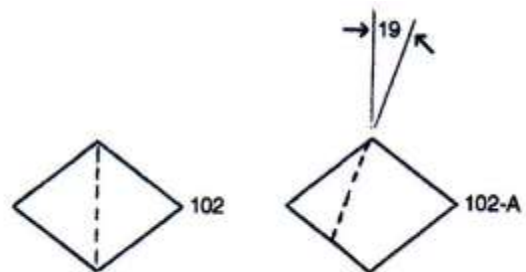

103. Missing Piece! The five bars with three holes each of *Missing Piece!* closely resemble those of the six-bar *Cuckoo Nest* #21, hence the farcical name. The geometry is totally different. In this version, three of the dowels are attached to bars to make two elbow pieces and one cross piece. The holes are drilled at an angle of 78 degrees to the axis of the bars, which angle is critical. I determined the spacing of the holes by trial and error to be the minimum possible, or close to it. I made 80 of these in 3/4-inch birch for use in the IPP15 exchange.

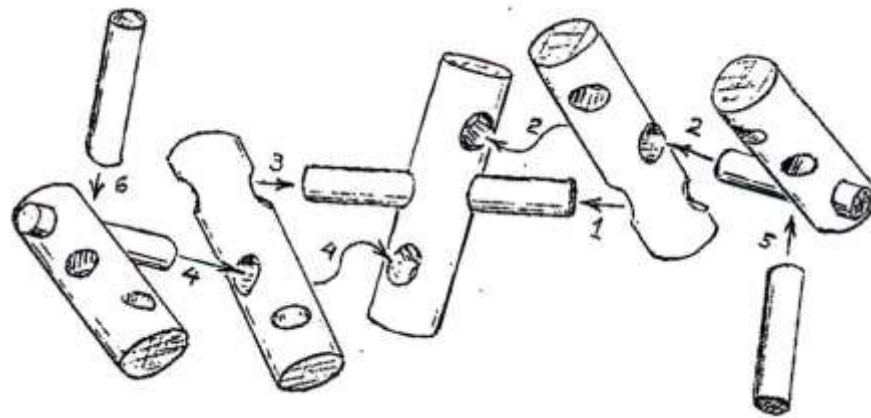

104. Tech Sticks. This is a distorted variation of *Hexsticks* #25-A with the now familiar symmetry of a brick. I thought *Isosceles* #101 and a few others were challenging enough to make, but *Tech Sticks* tops them all. I made only seven, plus two more of version 104-A, which is the same but in three contrasting woods. If you look closely (and I have doctored the photo accordingly), you may be able to see that three of the ends of the sticks are split, which allows the three key pieces to be removed first. As in *Isosceles* #101, the displaced blocks are attached to adjacent pieces, making three augmented pieces. Those nine that I made went, sans instructions, only to puzzle experts. Being familiar with my usual diabolical schemes, and with *Hexsticks* in particular, would have been an aid in solving. I did not receive any threatening mail.

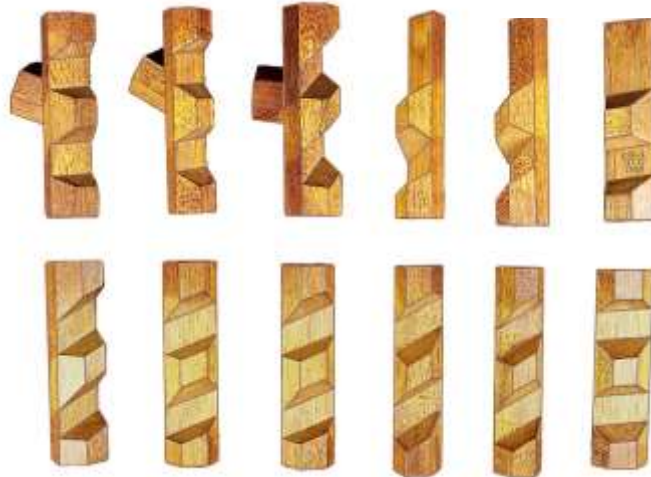

104-A. Tech Sticks. The same but made with three dissimilar woods. In addition to artistic appeal, another reason for using contrasting woods arranged symmetrically is to make an otherwise difficult puzzle slightly easier to assemble. The multi-colored pieces of the model shown are arranged symmetrically, but not in the most obvious of ways. They are arranged such that no like woods are next to each other.

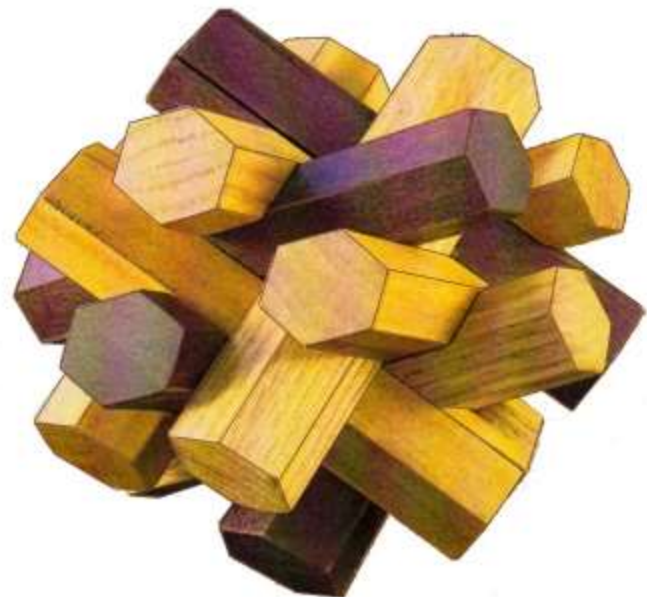

105. Lock Nut. This is an unusual variation of the diagonal six-piece burr that uses pieces with 1x2 rectangular cross-section. There are two mirror image kinds of pieces, three of each, and they assemble with tricky coordinate motion. Each piece has two diagonal notches, one deep and one shallow. There must be plenty around to copy, for I made 90 of them for the IPP16 exchange, in Honduras rosewood, a dense and stable wood easily identified by its pleasant spicy smell when worked.



106. Burr Noodle. It has two kinds of pieces, three of each, and the final step of the difficult assembly is the mating of two mirror-image halves. The pieces have rhomboid cross-section. It needs to be made of a stable wood such as this one in padauk, with the queer notches very accurately cut. But even then, not one of my better burrs. Why? Because I see it now in hindsight as difficulty just for the sake of difficulty, with no redeeming feature. Also, I have seen one forced together the wrong way. I made 100 of them for the IPP17 exchange. The drawing is of piece A. Piece B is its mirror image.

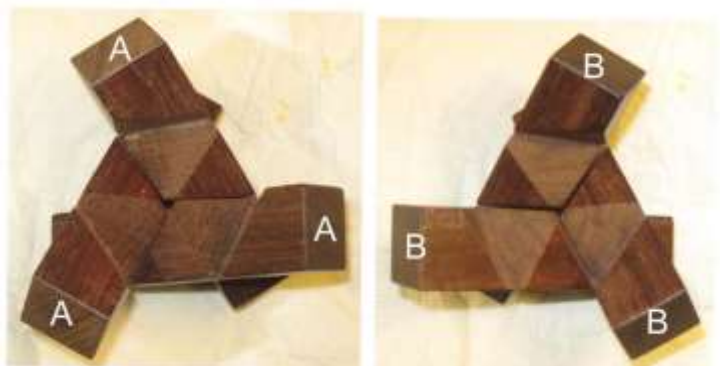
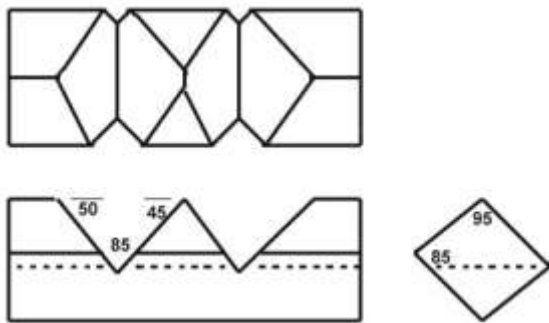

There was a variation of this puzzle with all dissimilar pieces called *Reluctance* #106-A, probably hopelessly difficult. Thankfully I believe it never got beyond my one experimental model, the destiny of which is unknown.

107. Trillium. Think of *Trillium* as *Seven Woods* #42 compressed by 15% along a three-fold axis, making it identical in principle and nearly in shape to *Disinclination* #99. Not sure now why the separate listing for such similar designs. See #99 for drawing of pieces. An IPP exchange.



107-A. Augatron. Here we have added six blocks onto *Trillium* to make six dissimilar pieces. Beyond that, I have no record of just how those blocks were added (nor do I think it is very important). I made only four in 1995.

108. Nonesuch. This was yet another distortion by compression, this time of *Four Corners* #6. I must have been in a distorting mood at the time. Thankfully I made only two. But brace yourself; yet more distortions are coming. I believe it is compressed along a three-fold axis.



109. Slocum-Pokum. This is a confusing variation of *Pin-Hole* #20 that uses sticks of 85-degree rhombic cross-section rather than square. An innovation is the use of a key pin that refuses to be poked loose but must instead be extracted by pulling, hence the helpful name. I have been asked if I think it strange that my business is making things more difficult, while nearly everyone else in the world is trying to make life easier. I suppose so, but I don't lose any sleep over it. Occasionally I find a soft spot in my heart and drop hints that are actually helpful, although perhaps not this time. An IPP exchange.

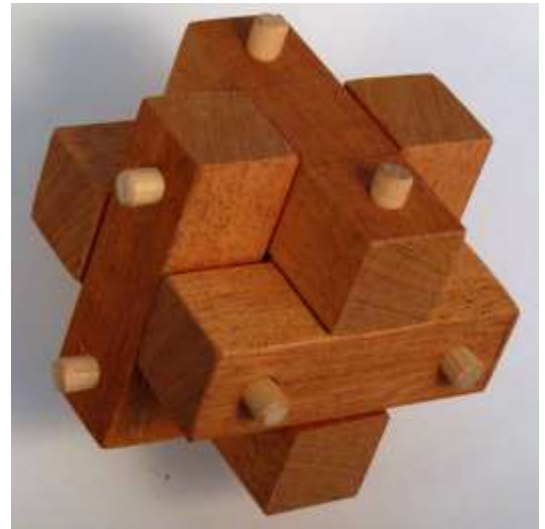

All six pieces are dissimilar. They assemble in the order shown, left to right, top to bottom. This particular model was made just for the photo. It is distorted by ten degrees rather than the standard five for greater clarity.

109-A. Foul Dowel. This is a variation in turn of *Slocum Pokum*, using round dowels rather than rhombic sticks, making it even more entertaining. All holes are drilled at an angle of 85 degrees to the axis of the dowels. All pieces are again dissimilar, and they are again assembled in the order shown.



110. Octo Burr. You won't likely find many *symmetrical eight-piece* burrs made with square sticks but *Octo Burr* is one such, making it possibly unique. Six of the sticks of this unusual burr are joined in pairs, so there are actually five puzzle pieces. An IPP exchange.



Assemble in order shown.



111. Lost and Found. This one has an interesting history. When for a brief time I had a business agent (see Part 2, Background), I plied him with models of puzzles that I hoped to see licensed for manufacture. But he soon quit the business and moved far away, taking several of my models with him. I considered them lost, but fortunately I had saved plans for at least some of them. Twenty-two years later, a large box mysteriously arrived in the mail from Spokane. In it, but with no explanation, were about a dozen of my long-lost models including of course this one, dated 1975. All six pieces are identical. The final step of assembly is the mating of two halves. Each half assembles with coordinate motion, yet the two halves are entirely dissimilar (see photo), making it quite a departure from most previous designs (with more close relatives soon to come). Mahogany.

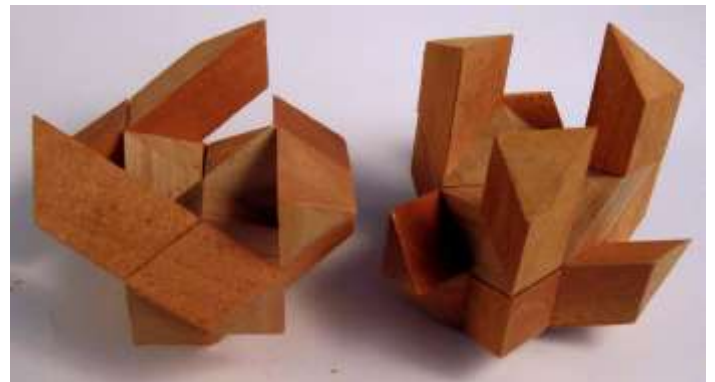
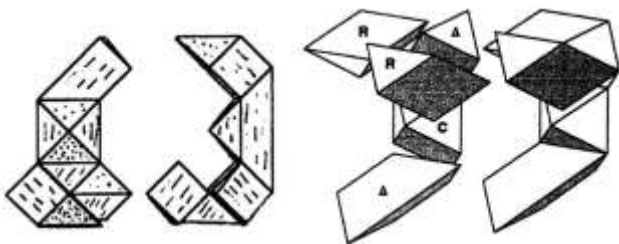
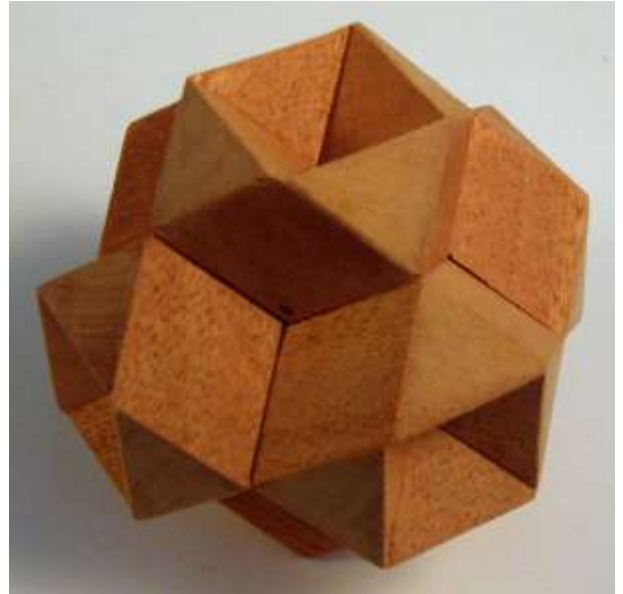

111-A. Lucky Star. *Lost and Found* has several interesting variations. *Lucky Star* has blocks added to give it the shape of an intermediate form of the stellated rhombic dodecahedron. For the rest of the description, see *Lost and Found* #111.

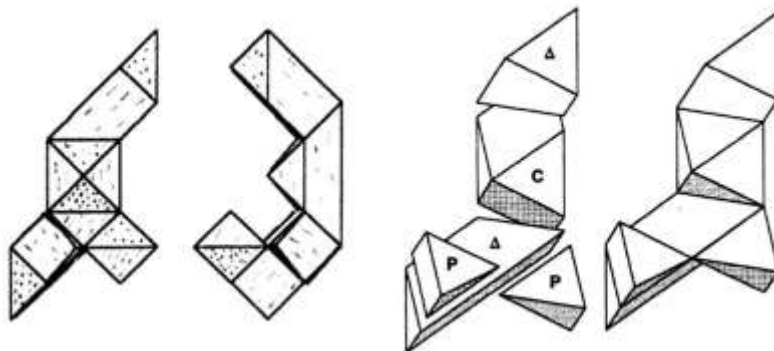
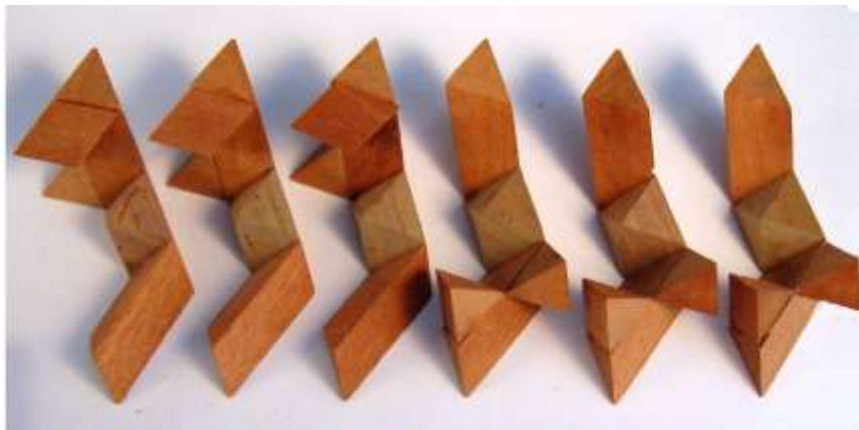
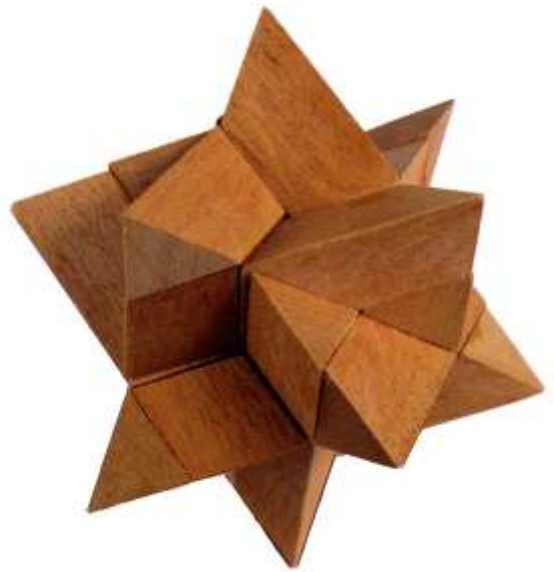

111-B. Star Dust. This starry relative has yet more blocks added and the shape of the third stellations of the rhombic dodecahedron.

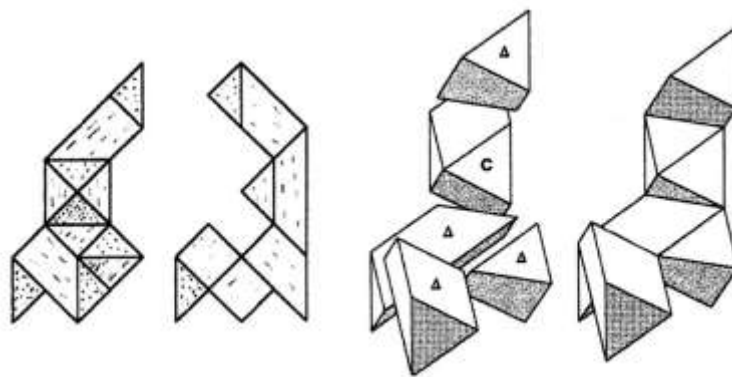
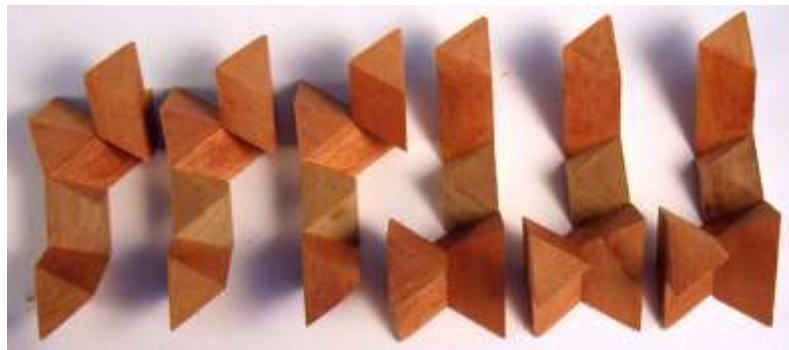
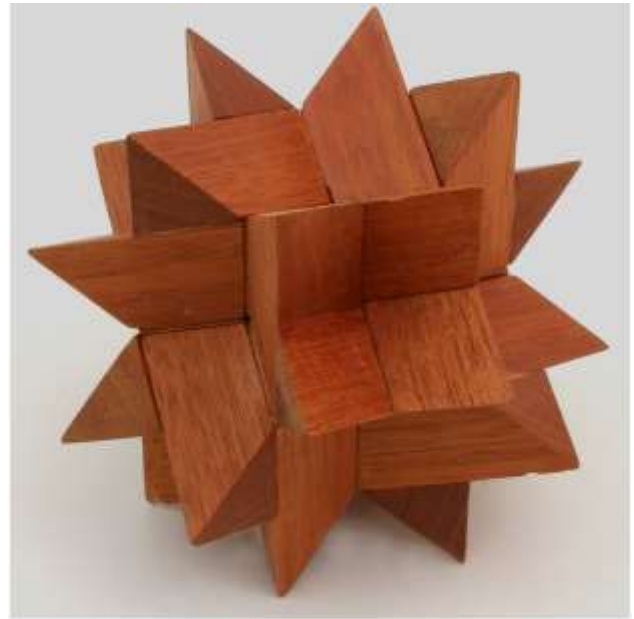

111-C. A-B-C. The next and most unusual of these variations is *A-B-C*. It has three kinds of pieces, two of each. It goes together in two halves of three pieces each, and of course one might naturally assume each half to be made up of pieces *A-B-C*, hence the usual helpful name. The pieces even come lettered for further help. But in the world of puzzledom, things are not always that simple. You might also assume that the name suggests “as simple as ABC,” but again....

Assemble *A-A-C* clockwise, and *B-B-C* counterclockwise, both by easy coordinate motion; then join the two halves.

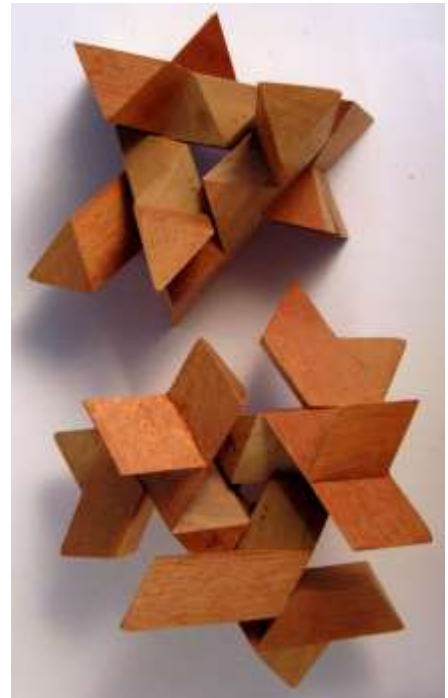
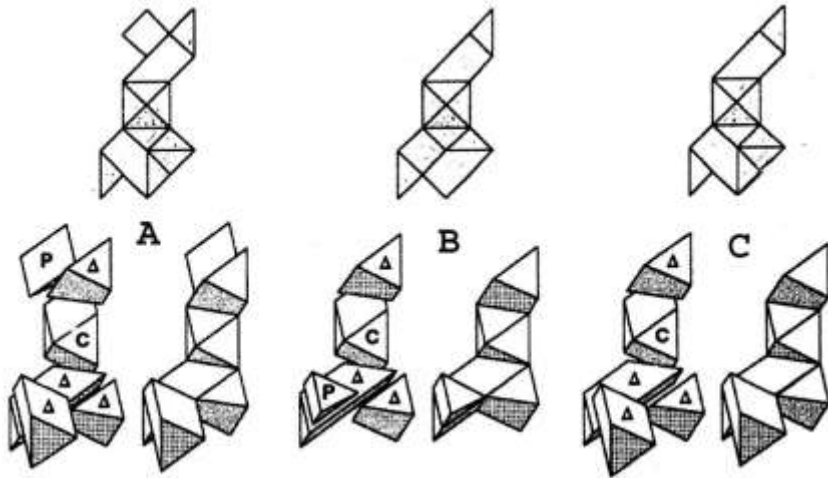
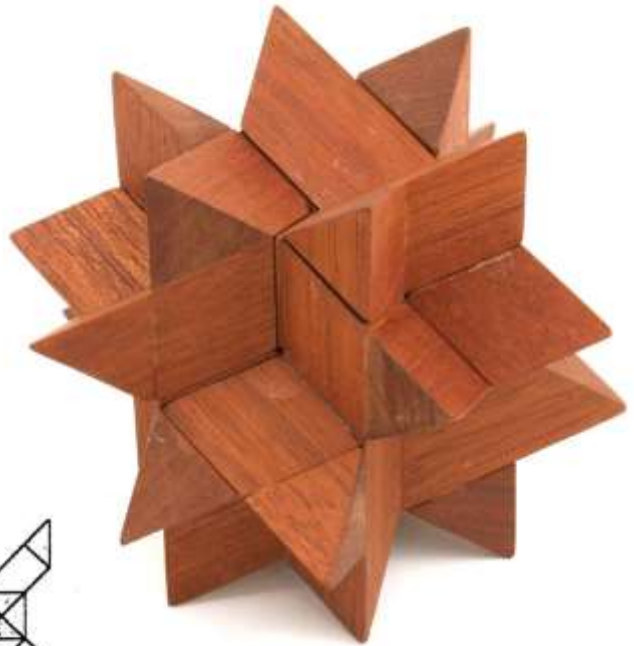

111-D. Evidently there was yet another member of the prolific 111 family, this one unnamed. According to the 2003 *AP-ART*, it had two kinds of pieces, three of each, and they went together in the usual two dissimilar halves. I made only one and did not record the details. But I think we have seen enough already and it's time to move on.

112. Burr Muda. No doubt you've heard of the devilish Bermuda Triangle - probably just a harmless myth. But watch out for *Burr Muda*, with its four triangular faces no less. The six identical pieces assemble with coordinate motion. The accompanying instruction sheet, part of which is pasted in below, gave actual helpful assembly hints such as the use of tape or rubber bands to get the little devil started together. Perhaps it should have also come with an apology. I never was too keen on dexterity puzzles unless not woefully difficult and with some redeeming features that justify. Not so sure about *Burr Muda*. However, as compensation I did make available an assembly jig.



To reassemble, note first that all six pieces are identical and symmetrical. Take any three pieces and tape the corners of their faces securely together, as shown below in Figure 1. Use a strong, sturdy tape such as mending tape. Place this subassembly face-down on a flat surface. Drop the remaining three pieces into place on top, holding them in place by taping their corners to those of the bottom subassembly in the same manner. The three points that interlock at the top should appear as in Figure 2. This same pattern is repeated in three other places. Put rubber bands around each of the three upper faces, as shown in Figure 3. (It may be possible to assemble this puzzle without using either tape or rubber bands, but if so, I have not yet been able to.) Now carefully hold the assembly cupped in your hand and remove the tapes, a bit at a time, while engaging the pieces by not more than one-sixteenth of an inch as shown in Figure 4. When all of the pieces are slightly engaged, work the puzzle gradually together.

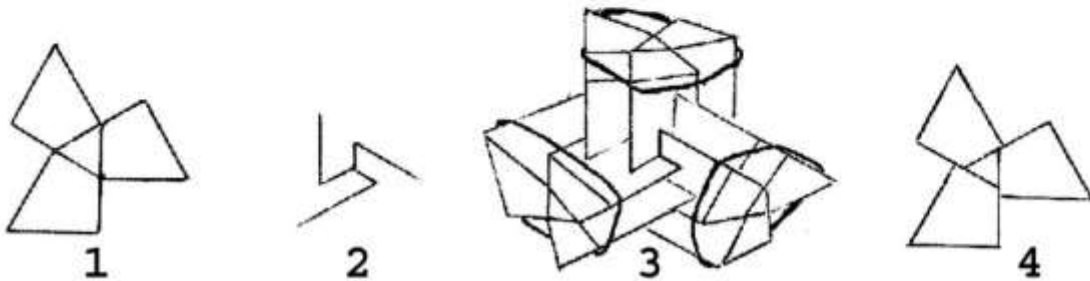

113. Sliparoo. This is a simple burr with six identical pieces. It is easy to assemble, at least for the first five pieces. But oh, that last piece.... This puzzle could be considered a companion to *Burr Muda*, and of the two is much easier to make. The two end blocks are made from 7/8-inch square sticks cut at a 55 degree slant. They are glued to the usual six-sided center block of size 3/4-inch. An IPP exchange.

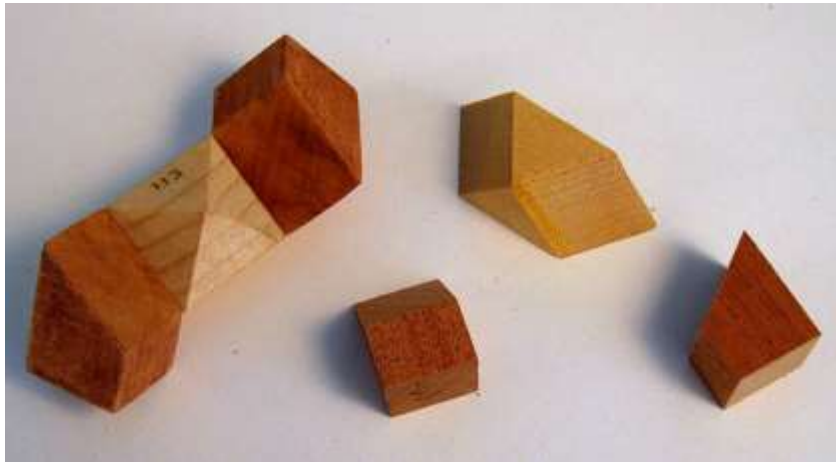

114. Cluster Plus. This one has a superficial resemblance to *Cluster Buster* #49, but is more difficult to assemble. The top three pieces subassemble clockwise A-B-C with coordinate motion. The bottom three pieces subassemble counterclockwise A'-B'-C' likewise with coordinate motion. These moves require that the vertex of the center blocks be flattened slightly, as can be seen. The two halves then slide together.

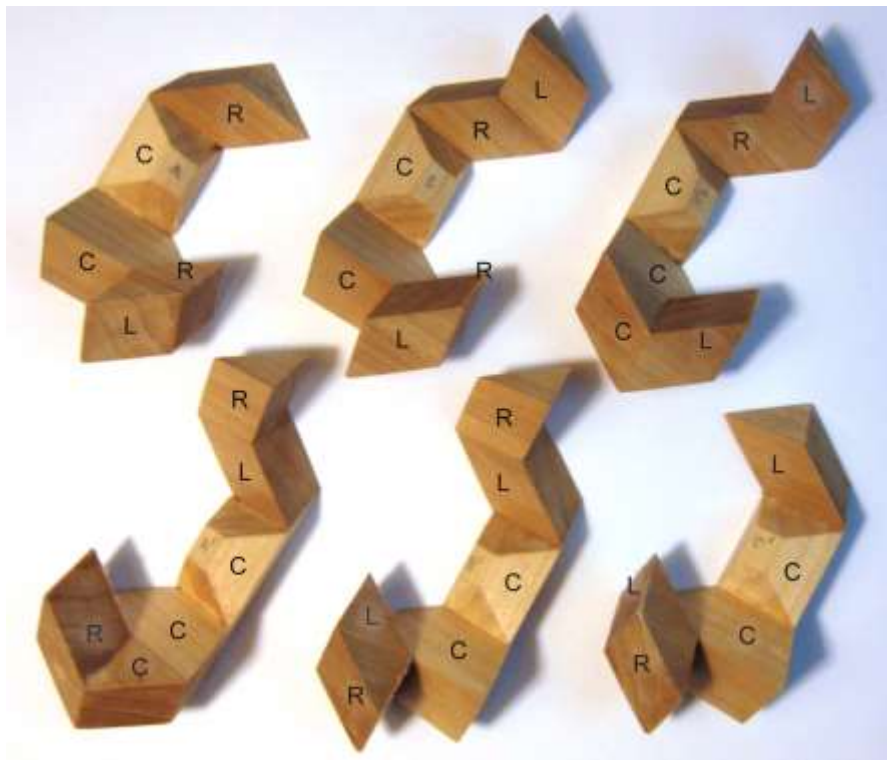

115. Fancy This! This is an unusual seven-piece polyhedral puzzle in four woods having the following features. Contrasting fancy woods arranged in isometric color symmetry, all pieces dissimilar and non-symmetrical, serial interlock, and baffling coordinate motion. Although many other AP-ART creations have had one or more of these features, this is the first to combine all four into one puzzle. But note the similarity to *Seven-Piece Third Stellation*, #73.



Assemble in the order numbered, starting with 1-3-2 counterclockwise by coordinate motion.

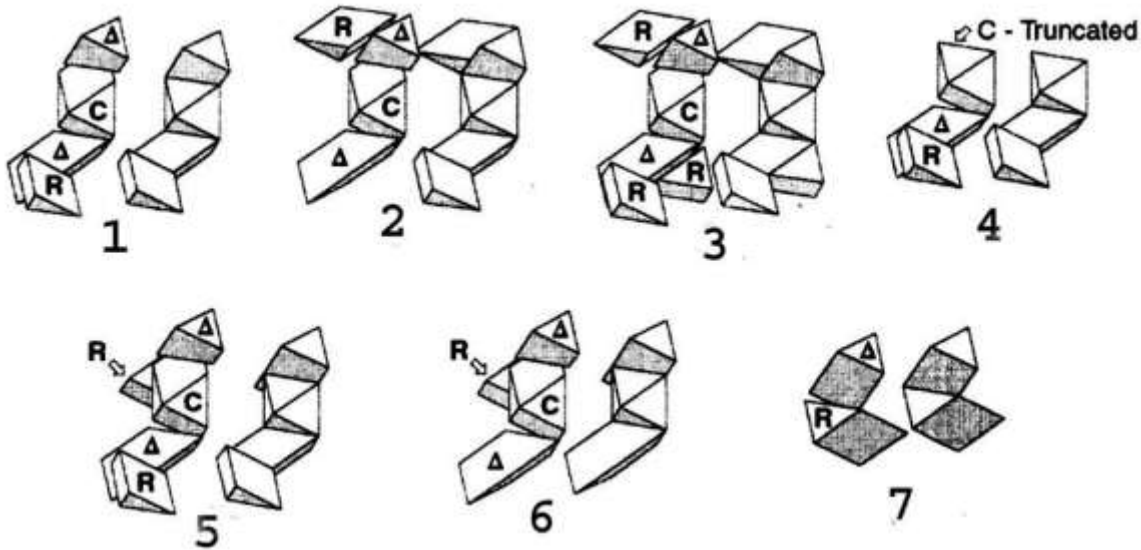

115-A. Fancy This! This version is in all one wood, adding to the difficulty. This well crafted reproduction was made by Wayne Daniel for the IPP exchange.



116. Burr Circus. According to my records, I made and sold six of these in 1995, but I did not save any design notes. Perhaps I thought they were not worth saving. I considered it a lost design until one showed up recently in my daughter's collection. This puzzle has the usual complications introduced by crooked notches. It has two kinds of pieces, three of each, and the two halves are mirror image. The two halves mate along the one sliding axis.

Now they are turning up right and left. Evidently they were in an IPP exchange. Eric Fuller recently sent me this one that he crafted nicely in purpleheart. I have attempted to draw one of Eric's pieces. The other kind of piece would be its mirror image. I have exaggerated the angles slightly for clarity, as the deviation from the ordinary diagonal burr would normally be about five degrees, although any amount should work. The sticks are $\frac{3}{4}$ -inch square.

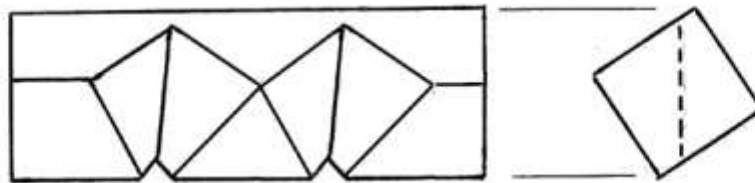

117. Overdrive. As the name suggests, *Overdrive* is the final of our “gear” series (see #92). There are two kinds of pieces, three of each, as shown. They are easy to make by attaching triangular stick segments to standard six-sided center blocks. The small blocks on one end are standard **P** (Rhombic Pyramid) blocks. Assembly requires tricky coordinate motion of all six. I even provided an assembly jig (also shown below) with instructions. Furthermore I made them of slippery, oily teak to help lubricate the gears and make the assembly slip and slide more smoothly. Shown in the other photo is a partially assembled *Overdrive* sitting in the jig ready to be compressed together.

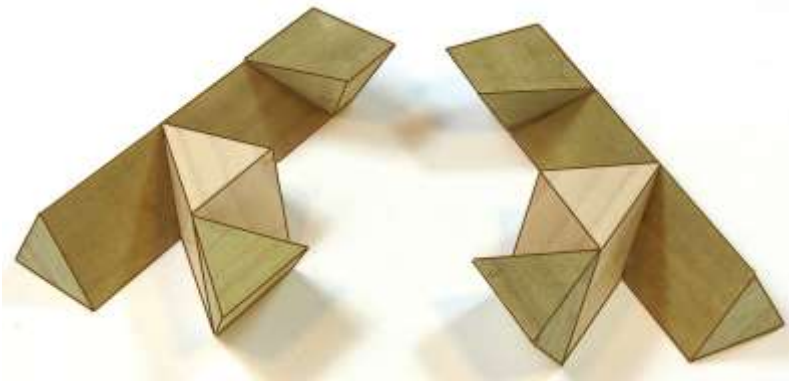

118. Three Bunnies. This one consists of three dissimilar non-symmetrical pieces that assemble with coordinate motion. Given a little imagination, the three pieces resemble bunnies. Persons wishing to make reproductions may find the photo of the pieces somewhat lacking in detail, as did I when I attempted to make another one. However, it was an IPP exchange puzzle, so there must be plenty of them around to copy.

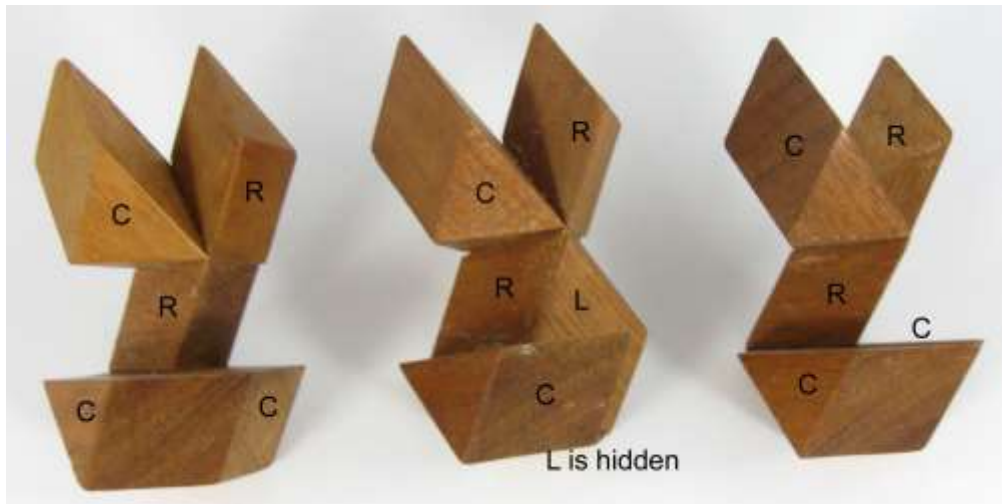
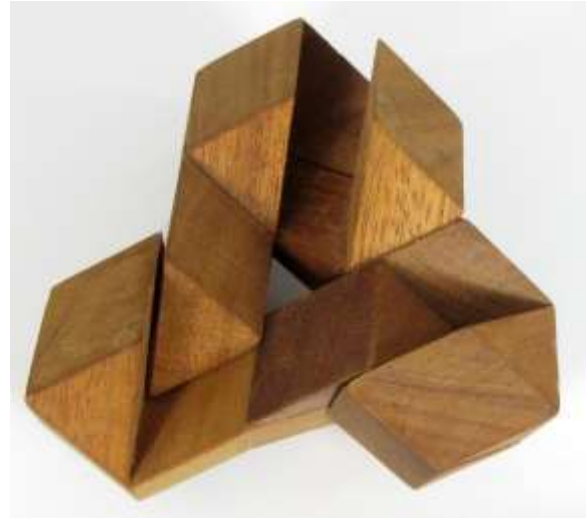

119. Cluster's Last Stand. This is the next in the *Cluster* series (see #47, #48, #49, and #114) but, contrary to what the name might suggest, not the last. The six non-symmetrical pieces assemble with total coordinate motion. There are three kinds of pieces, two of each. Each piece consists of three six-sided center blocks and two tricky end blocks. The critical angle seen on the end view of the end blocks of the pieces center and right is 18.4 degrees, and on the left the usual 45 degrees. The end blocks are, in effect, six-sided center blocks cut in two, and in the top photo made of a contrasting wood - padauk. By the way, note pencil dots marked on the center blocks, below and elsewhere. I do this as a guide to assembly, so as to not waste time trying to put my own creations back together again.



120. Nine-Piece Pentagon. These nine pieces fit into a pentagonal tray. I “mass produced” six of them in zebrawood by slicing off a bundle across the end-grain like sausage. The design was created by first tessellating the pentagon into 36-54-90-degree right triangles and then recombining them into nine dissimilar non-symmetrical puzzle pieces. It is believed to have only one solution. An IPP exchange.

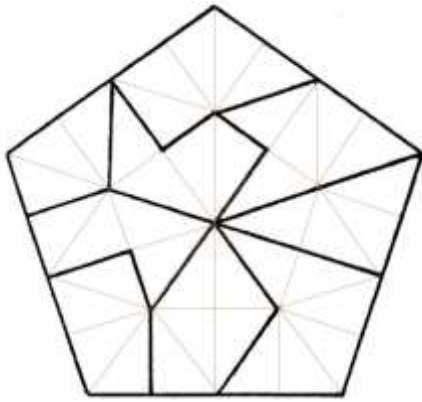

121. Pentagonal Star. The 13 non-symmetrical pieces fit into a star-shaped tray. In case it isn't obvious, puzzles of this sort are created by tessellating the whole area by some regular pattern and then recombining some of the parts to make dissimilar puzzle pieces that seem willing to fit neatly together a great many ways, but preferably only one right way. In this and the preceding, the basic unit is a right-triangle, as illustrated in the drawing. *Pentagonal Star* is likewise believed to have only one solution, but you are never sure, especially with this many pieces, until someone conducts a complete analysis, probably by computer. This reproduction is laser-cut from plywood by Walter Hoppe.

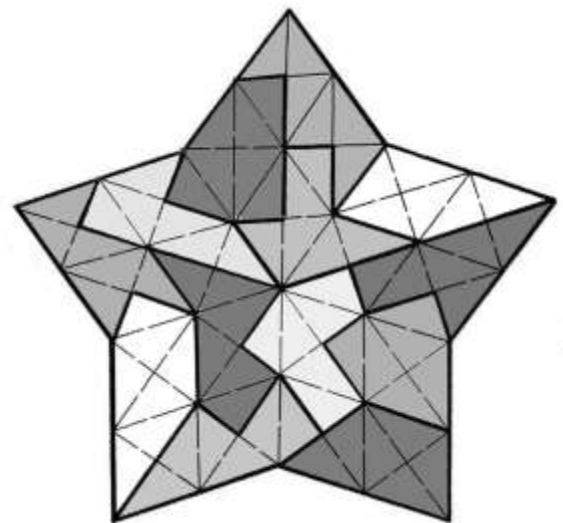

122. Rhombic Blocks. The nine pieces of *Rhombic Blocks* represent all the ways that three rhombic blocks can be joined together, which by sheer luck fit nicely into a hexagonal tray. But, alas, according to this computer analysis by Mike Beeler, they fit fourteen ways, when only one way would have been preferred.

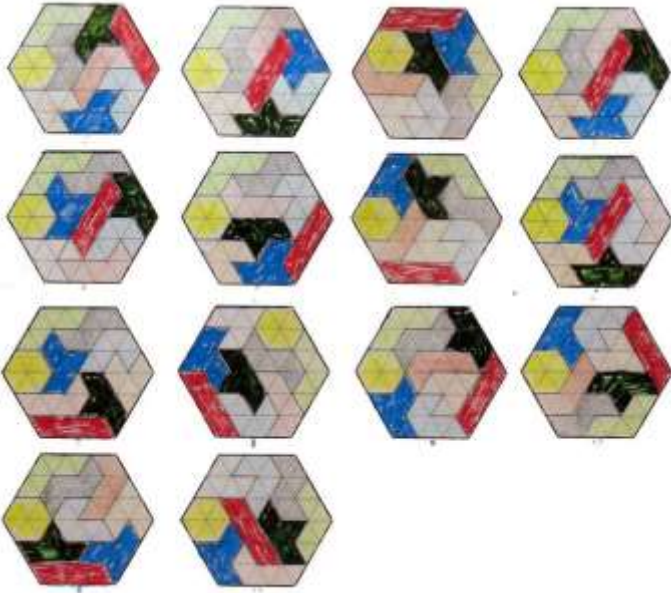

122-A. Nine Pairs of Trapezoids. On page 19 of *Geometric Puzzle Design* I mention the possibility of joining 3-triangle trapezoids in pairs all possible ways. The resulting nine pieces also assemble into a hexagon. I must have found at least one solution and made at least one model, which as usual has long since disappeared. I do not know how many solutions exist, although someone may have reported investigating by computer and I lost the results. But here is one example beautifully crafted in nine contrasting colorful woods and given to me by a skilled woodworker so far unidentified.



123. Rock Pile, later renamed **Abel's Chimney**. It has the appearance of an eight-piece non-solid diagonal dissection of an almost cube neatly installed in a box, but with two small pieces left out, and the confusing problem is to fit them in. The eight pieces are marked R-O-C-K, P-I-L-E so that they could always be more easily restored to their original positions. Here is yet another example of where I, the designer, probably had more fun designing it than anyone would likely have laboriously trying to solve it. However, this is not a puzzle to be solved by trial and error, there are so many thousands of choices. The drawing shows how the pieces were created. A nearly cubic solid is cut into eight pieces by three mutually perpendicular planes. The planes are offset from center so that all pieces will be dissimilar and non-symmetrical. Thus each piece has two corners that fit snugly into the corners of the box – the original outside corners and the diagonally opposite ones that come together in the center. The trick is to exchange each piece with its diagonally opposite one without rotation. This is done by swapping the top four with bottom four, then left with right, and then front with back, all done without turning any.

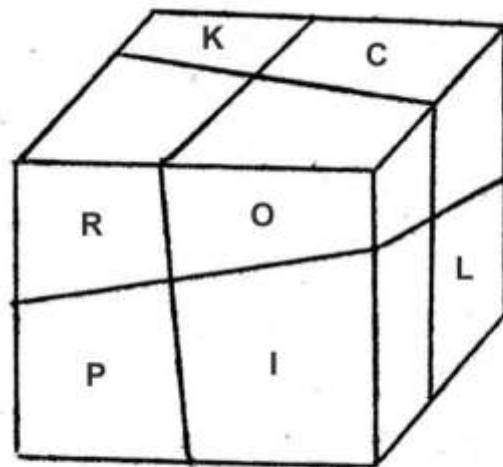

E is hiding in back

124. R-D-16. No, not a new drug, *R-D-16* is a symmetrical cluster of 16 polyhedral blocks joined to form four serially interlocking puzzle pieces. The shape could be described as a truncated tetrahedron. It was first made with glued-up rhombic dodecahedral blocks double the usual size, hence the incidental glue joints that may be visible in the photo. I later made an alternate version of basically the same puzzle but with edge-beveled cubes (photo below).

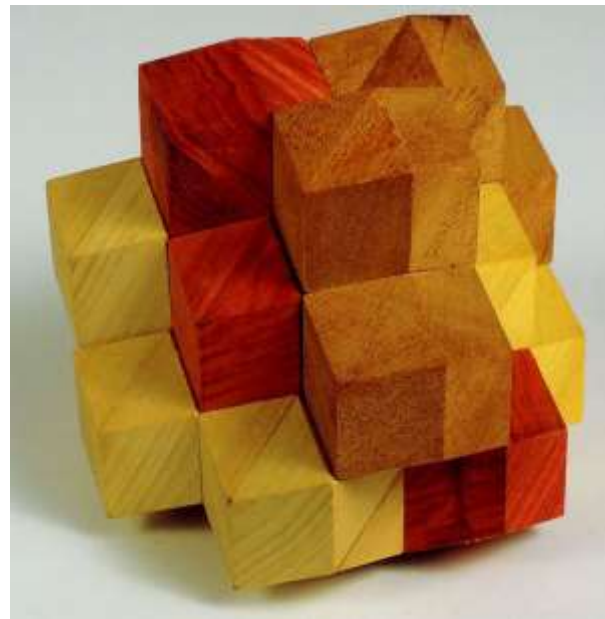

BOTTOM

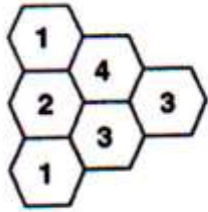

TOP

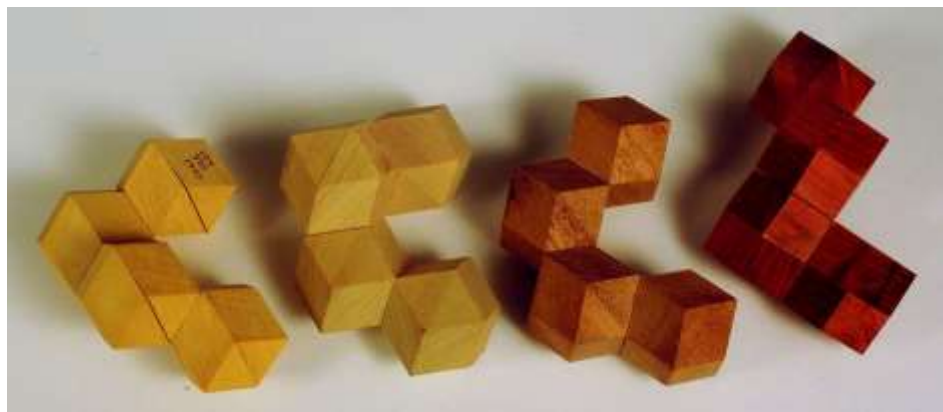

125. Archimedes' Tile. This scheme is based on the tessellation of the plane into squares and equilateral triangles. It never got beyond the experimental stage, mostly because the tray was too much trouble to make. But now it can be made easily by the laser process, as in this reproduction by Walter Hoppe. This seven-piece example is too trivial to be considered much of a puzzle, but for those who enjoy tinkering with such things, this tessellation readily lends itself to expansion with more puzzle pieces.

Note: This model contained an erroneous eighth piece consisting of a single triangle that had somehow become detached, a mistake (probably mine) that also appeared in the 2003 AP-ART. I have reattached it in this photo using Photoshop. And just for fun, I have attached the wayward triangle to a different piece this time, the one at lower right.

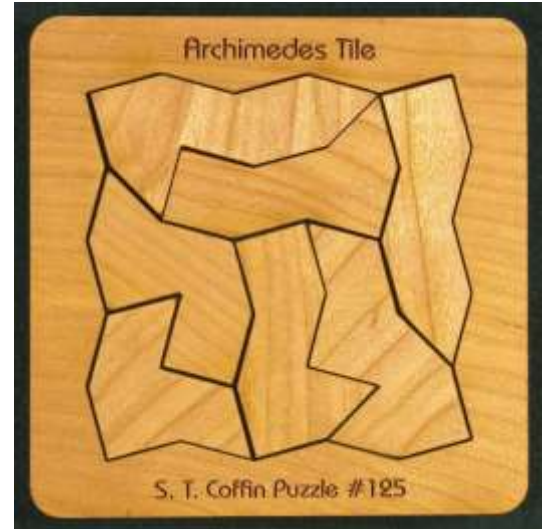

126. Stew's Scrap

Pile. My idea of a joke, *Stew's Scrap Pile* is rather special and possibly unique in that it combines both the standard six-piece burr and the diagonal puzzle in the same puzzle. It assembles by fairly easy coordinate motion, as shown in the second photo. And it is easy to make. The drawing shows top, front, and side views. I made a batch of these for the IPP exchange.

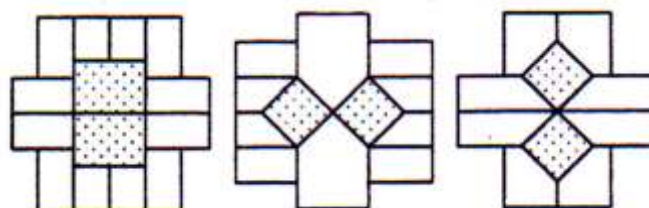
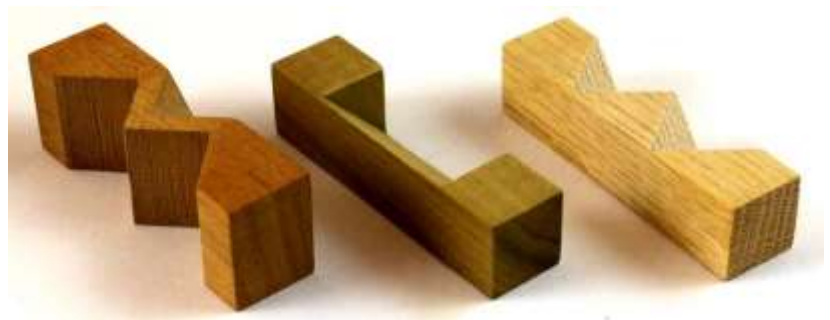

127. Make Room. Eight rectangular blocks, all dissimilar, come neatly packed into an 11x9x7 box, with a 1x1 hole in all six sides as shown. The problem is to repack them to make room for the leftover ninth block. The eight blocks are 2x5x6, 3x4x5, 3x4x6, 3x4x7, 3x5x6, 4x4x5, 4x5x5, 4x5x6, and the leftover block 2x2x5. Oh well, at least I had fun designing it. Sometimes that's the whole idea. Also, someone might have fun determining how many solutions exist, probably by computer. I designed it around only my one known solution and did not bother to probe further. This reproduction, boxed in Plexiglas, is recently made using up scraps of eight dissimilar woods.

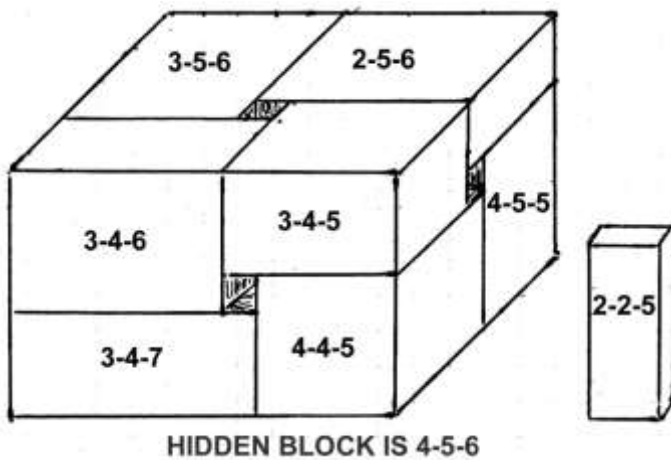
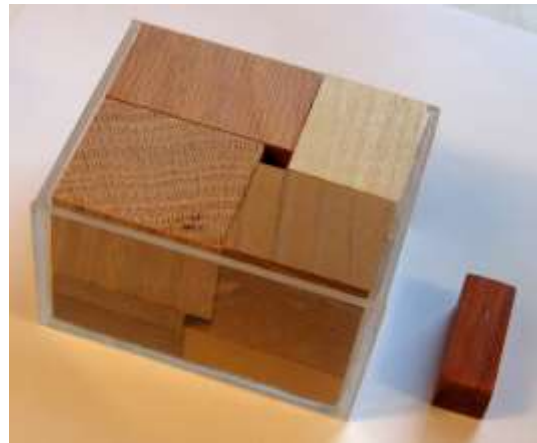

127-A. Make Room. This version is similar to the above but with slightly different dimensions. The blocks are 2x5x6, 3x4x5, 3x4x6, 3x5x6, 4x5x7, 4x5x8, 4x6x7, and 5x6x7; the box 9x10x11; and the leftover block again 2x2x5. The one shown here was nicely made in walnut (?) with Plexiglas box by Interlocking Puzzles for use as an exchange puzzle in 2001.

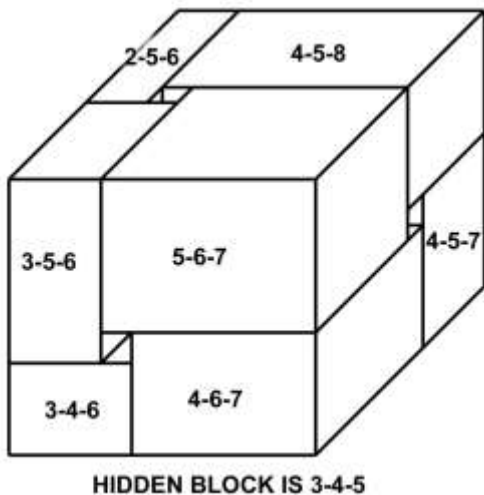

128. Combination Lock. This sequel to *Rosebud* #39 is quite unusual in that it combines baffling coordinate motion, combinatorial confusion, and puzzling serial interlock all in one. And now (if only one could write in a whisper), time for another confession. I am not very good at solving puzzles made by others that are so often given to me. I often can't even solve some of my own. To put it another way, I tend to be impetuous and would rather not expend the time. Instead, I will look up the solution in my files. I would much prefer spending my time doing more creative things, and ones that I am probably better at. I will work diligently at some new project for countless hours, often well into the night, and think nothing of it. I made this model recently just to pose for the photo, but having lost my assembly directions I resorted to asking Nick Baxter for them. The six dissimilar pieces are made of what I have been calling standard AP-ART building blocks, as explained in the Appendix.

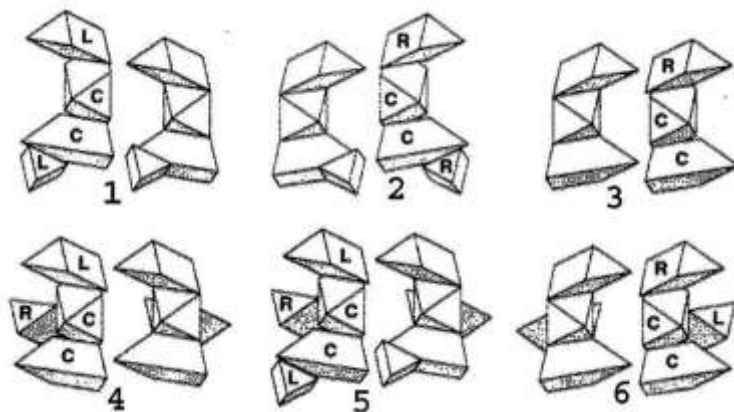

To assemble, first subassemble pieces 1 – 2 – 3 clockwise as shown right. Then insert 4 opposite 2 and 5 opposite 3. With those five pieces held loosely together, gradually wiggle 6 into place and compress. The *Rosebud* assembly jig works with this puzzle also, but it is not necessary.



129. Dudd. The name *Dudd* is perhaps misleading (as well as being misspelled). The idea for this puzzle came from a similar one that Bill Cutler designed many years earlier. His looks like an ordinary six-piece burr except that each piece has a pair of additional diagonal notches. Half of those notches are unnecessary, and so *Dudd* has only six, and is thereby much trickier to assemble.



129-A. Missing Notches. It is similar to *Dudd* but has ten diagonal notches instead of the required minimum of six, for added confusion. The idea behind the name was to suggest that I was trying to make the Cutler version but left out two notches by mistake. Some got it, some didn't. On second thought, *Dudd* might have been the better choice for the IPP puzzle exchange. Same photos work for both versions.



130. Slider. This is a six-piece diagonal burr made with sticks of rhomboid cross-section, 0.750 x 0.800 inches, and 84 degree angle. It uses two types of pieces, which are mirror image, three of each. The perplexing solution involves tricky coordinate motion. I made five of them of maple in 1997, but saved only sketchy design notes, from which I have here attempted to sketch what I think the pieces should look like. I have exaggerated the angles for clarity. If you really insist on making one, try finding one of those five to copy. But for all that bother, it is not one I would recommend.



131. Six of Diamonds. This one was similar to *Slider* #130 except for having all six pieces dissimilar, which must have made it hopelessly difficult. I think I got carried away and went too far. It was used in the IPP puzzle exchange in 1998, and I wonder how many had the time and patience to solve it. I did not save any design details, but I made 100 of them so there must be a few still around



132. Tectonic. Everything learned from designing the previously listed distorted burrs (#96 to #98-A) is combined into this one innocent looking little six-piece burr. All of those previous burrs involved one or two kinds of crookedness. *Tectonic* employs all three. The model is in tulipwood, and is viewed along one of the axes to show the 5-degree slant of the notches. In the drawing, the angles are greatly exaggerated for clarity. The model is made of 0.750-inch square sticks, with length of 2.95 inches. If any longer, the puzzle cannot be assembled.

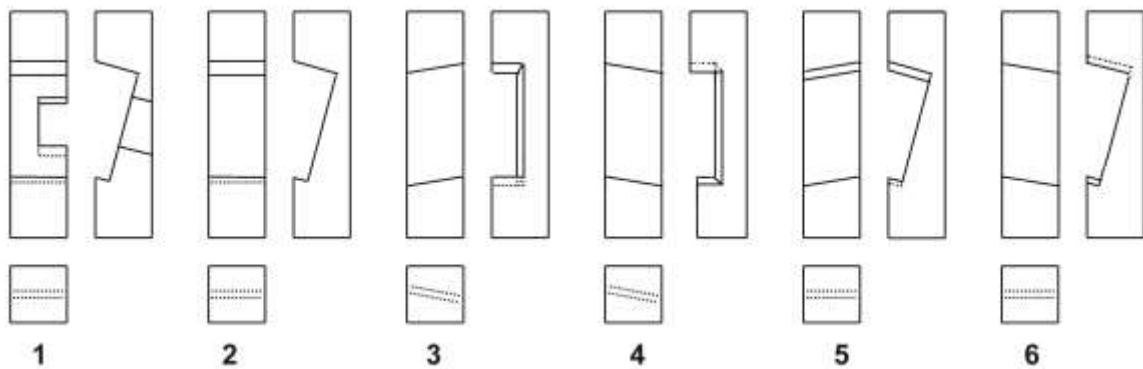
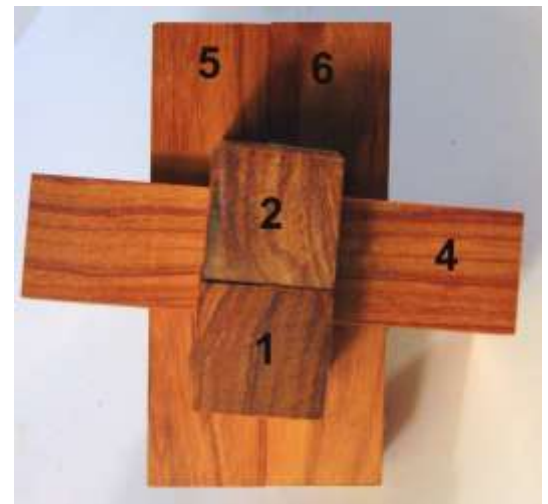

133. Few Tile. From my puzzle designs listed thus far, one can see that my specialty has been three-dimensional ones, more specifically geometric solids, and even more specifically polyhedral shapes. At craft shows, it was always the unusual polyhedral designs that drew the admiring crowds to our booth, especially those well crafted in exotic woods. But when it came to actually playing with them, it was usually the flat puzzles that got the most hands-on attention. I think they tend to be more inviting. I have tried to capitalize on that tendency by designing flat puzzles that are unusual and have some special charm, such as artistic appeal, novelty, or bewilderment without complexity. Another advantage that flat puzzles have over the 3D kind is that they are easier for the reader to visualize, to copy, and to make out of wood, cardboard, or whatever. *Few Tile* has four simple pieces that fit into a rectangular tray. Nearly everyone will naturally but hopelessly try to nestle the four pieces snugly into the four corners of the tray. After all, we have been putting things into square corners all our lives. Recognizing and exploiting habits like that is potent ammunition for the wily puzzle designer. When *Few Tile* was exchanged at the 1998 International Puzzle Party, I had the satisfaction of hearing that one puzzle expert declared it unsolvable. I continued to exploit this trick until people finally started catching onto it. To make a reproduction of *Few Tile*, you must copy this plan exactly, as there are several arrangements that almost fit.



134. Outhouse. When my original design was found to have numerous faults, it was modified several times with help from Edward Hordern, mostly to eliminate false solutions, but I'm not sure if we succeeded. He then used it as an IPP19 exchange puzzle, but only after changing the name to *Pool Puzzle*. The object is to insert all five blocks into the tray that has restricted openings. It is a sliding block puzzle of sorts combined with four-piece coordinate motion. My model shown here may not have been Ed's final IPP version.



135. Seven Irregular Hexagons. This was my attempt to design a puzzle consisting of seven dissimilar and irregular hexagons that would fit one way only into a hexagonal tray. When multiple solutions continued to crop up, after numerous attempts I abandoned this idea. Nevertheless this model was laser-cut by Walter Hoppe.



136. Tangram Plus. It may look a bit like the venerable *Tangram*, but the rhomboid piece is too long and refuses to fit in the usual way. Note that the square tray must be about five percent oversized, and note also that some of the corners have been slightly rounded (second photo). Brace yourself for another corruption of this classic pastime when we come to #155. But aren't there better ways to entertain one's friends? Nevertheless an IPP exchange.



Added note: My call for rounding some corners in the example above struck me as a design flaw. Accordingly I have revised the layout to conform to an exact square grid (below). The problem, which I leave to others, then becomes to discover the smallest rhomboid piece that will fit into the shaded area and yet still allow only this one solution.

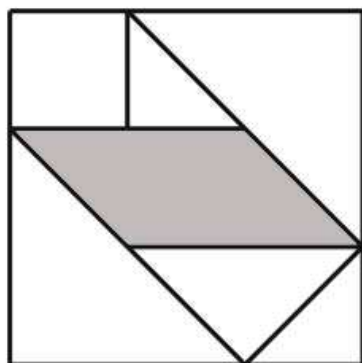

137. Engelberg Square. It was so named because I worked out some of the details with help from talented Elderhostel hiking companion Betty Anthony while vacationing in Engelberg, Switzerland. In spite of all Betty's help, it is not one of my better designs. It has unwanted multiple solutions unless very accurately made, and perhaps even then. But at least we had fun working it out together, and now I wonder whatever became of Betty. There are six pieces. My model below is in teak. The assembled model, right, was laser-cut by Walter Hoppe.







Incidentally, here is Engelberg Square Variation, designed by Nick Baxter and perhaps suggested by the above. It was used by him for the IPP Exchange in 1999. Presumably it overcomes the problem of multiple solutions. It was expertly crafted by Interlocking Puzzles. The two tilted pieces are T and square.



138. Piggy Box. This is a sort of shifting block packing puzzle. The five types of pieces are made of cubes joined different ways. Given a certain set of pieces, the problem is to fit them all into the box through the slit in the top. The round holes provide access for moving and rotating the pieces about by poking with an eraser. The instructions give five different problems of varying difficulty. I remember getting much pleasure from working out these solutions but I never got much feedback from puzzle solvers, so I always wondered. This well crafted model is by Saul Bobroff, who used a simplified version designated #138-A in an IPP exchange.

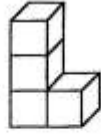

I saved many pages of problems and their solutions, way too many to include here, so instead I will paste in just a summary of the five that came on the instruction sheet of my version.

					
	PIN	BAR	VEE	EL	SQUARE
<u>Combinations</u>					
No. 1, Slipper	-	1	3	2	1
No. 2, Slider	1	1	1	2	2
No. 3, Stuffer	-	3	1	1	2
No. 4, Twister	-	-	4	2	1
No. 5, Packer	-	2	2	2	1

139. Sixes and Sevens. This description is taken from *AP-ART 2003*: Nine puzzle pieces made up of 54 triangular tiles joined together different ways fit into a hexagonal tray. This set uses all possible non-symmetrical puzzle pieces through size six plus two pieces of size seven. My design objective was to find two size-seven pieces from the set of 18 non-symmetrical ones that would yield a unique solution. For my first try, shown on the left, Bill Cutler's computer analysis turned up 146 solutions. The problem was further investigated by Mike Beeler, and he found there was no combination with unique solution. The closest, he reported, was the one shown on the right, with three solutions. Some other variations were investigated by Nick Baxter, and that is about as far as this playful pastime went. I believe I made only one in wood, and who knows what became of it.

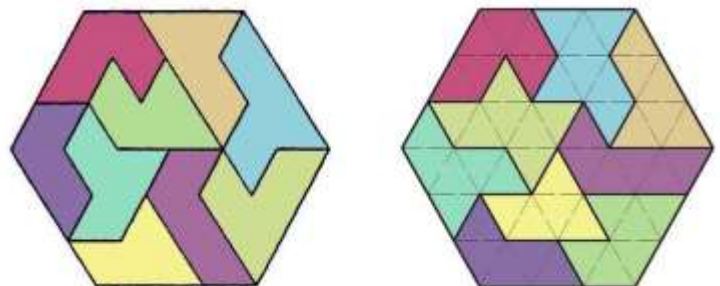

141. Isosceles II. Not to be confused with my other *Isosceles*, #101 (must have run out of names), this one has ten pieces made of light and dark isosceles right triangles joined different ways that fit into a square tray, and of course perfectly patterned light and dark.

Problem: Rearrange as necessary in order to find space for those two left-out pieces. Trouble is, they don't seem to fit anywhere. Careful inspection will reveal that they, and one other, are scaled up about 10% larger than the other seven.



So they make up their own little three-piece square, likewise perfectly patterned light and dark. Whoever would have thought?

142. Octagon (originally misnamed **Octahedron**). The lack of inspiration represented by this design seems to have been carried forward even to my choice of name (and mis-name). Thirty octagonal blocks are joined together into seven puzzle pieces. They were supposed to fit into the octagonal tray one way only, but they will fit other ways unless very accurately made, and perhaps even then. Consider this an aborted design. This reproduction was laser cut by Walter Hoppe.



143. Checkout. Historically, published dissections of the standard checkerboard must number in the many hundreds. In *Checkout* we simplify things by cutting the board down to 4x4 but then introduce some complications for a little more fun. All twelve pieces fit inside the half-sized checkerboard. Perhaps you may wish to try solving this puzzle by making one of wood or cardboard. If you do, make the board $4\frac{1}{4}$ units square rather than exactly 4. As shown, the solution is ever so easy, except for one slight problem: There seems to be some mistake - not quite enough spaces for all the pieces. Two extra triangles – count them. For a hint at the solution, examine *Checker* or *Windmill*. The model shown was expertly crafted by Tom Lensch for an IPP exchange.

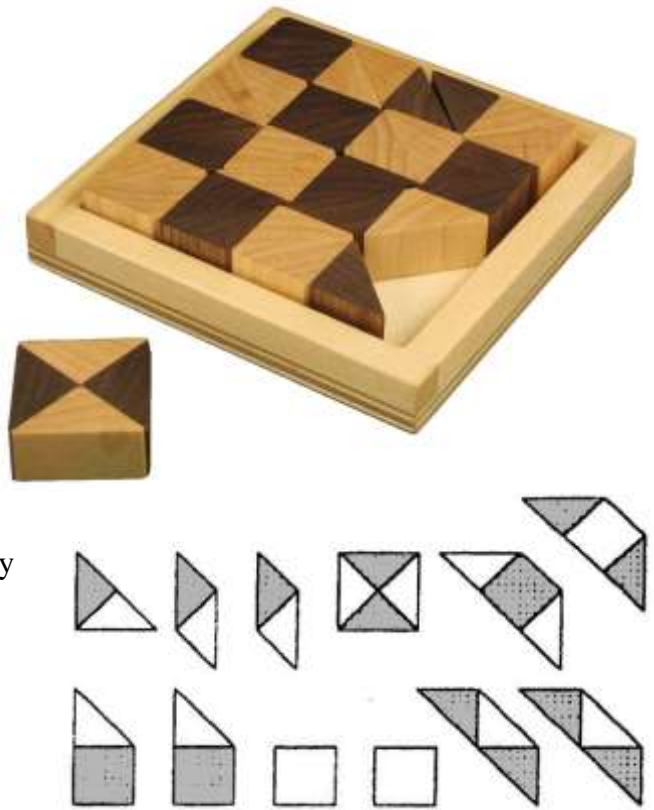

143-A. Checker. Nine pieces fit neatly into a perfectly colored mini-checkerboard, but alas with that one small triangular piece left over. Again, what's going on?



Well, of course. For clarity, I have drawn in the lines of dissection over this photo.

144. Windmill. The idea behind *Windmill* was to dissect the square into 68 isosceles right triangles and combine them into 17 dissimilar non-symmetrical puzzle pieces. Two contrasting woods are used so that a windmill pattern appears in either of the two solutions. Having that pattern makes the solution somewhat easier, but perhaps even more enjoyable. If you want to make this puzzle out of wood or cardboard, note that the triangles come in two sizes with areas in the ratio of 8 to 9. Therefore their linear dimensions differ by the square root of that ratio, or 0.94 to 1.00. My original model is in padauk and maple. Walter Hoppe made the laser-cut reproduction for the IPP exchange. (He also made #146 and #147.) For the enterprising puzzle inventor, here is opportunity to improve upon this unfinished design. Note that one of the pieces contains three triangles and one contains five. If possible, find a design with all pieces made up of four triangles. Note also that two of the pieces are very nearly identical, differing only by switching large and small triangles, another flaw. Worse still is having a second solution. Good luck! Of course, the other possibility for recreational math fans might be to prove that no such perfect combination exists.



In addition to my intended solution (left), Bill Cutler reported finding, by computer analysis, that *Windmill* had a second solution (right). So write this one off as another unfinished design.

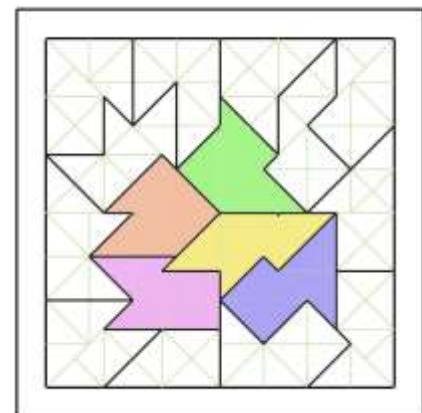
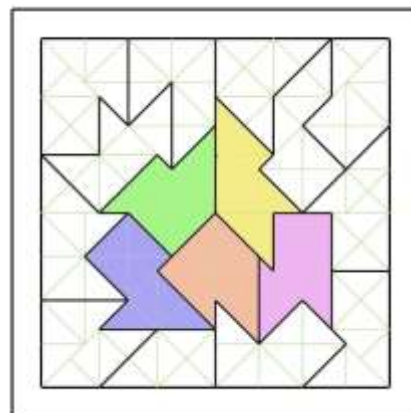

145. Lemon. The 10 pieces of *Lemon* are made of equilateral triangles and isosceles triangles joined different ways. It was found to have at least two solutions, so we ought to try again. (A larger version might be worth investigating.)

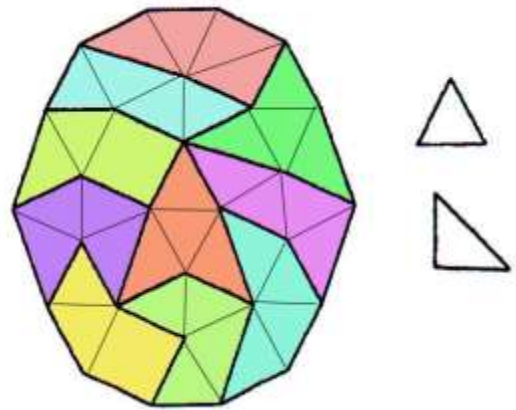

146. Lime. This was to be a companion design to *Lemon* using a slightly different pair of building blocks. But again there were multiple solutions, at least one of which is obvious by inspection. Both of these might benefit from redesign to have just one solution, if possible. An IPP exchange.

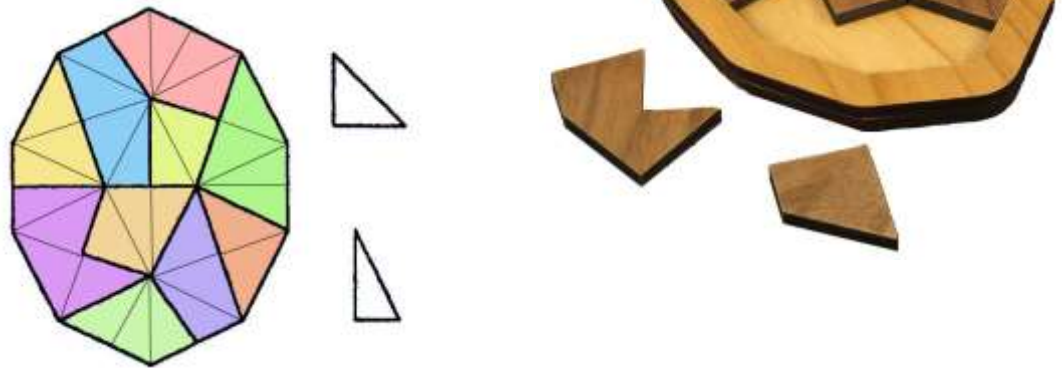

147. Pineapple. This one is based on the familiar tessellation of the plane into squares and equilateral triangles. In case it hasn't been made obvious by now, a combinatorial puzzle is one in which the pieces may be combined many different ways, ideally only one of which is the solution. This is best achieved when all the pieces, and the fewer the better, are dissimilar and non-symmetrical and fit obligingly together a great many wrong ways. It is a pastime that has been popular for centuries, with many thousands of puzzles published. Most of the obvious shapes of pieces have by now been pretty well exploited, yet the opportunity still exists for thoughtful design and artistic creativity. This *Pineapple* was precisely made by Walt Hoppe using a laser cutter. I do not know if *Pineapple* has multiple solutions, but let's hope not, so we can salvage at least one from this group of three.



Here, tossed in as an afterthought, is a different tessellation using the same squares and triangles. Expanded versions might have puzzling possibilities, but I never got around to exploring them.

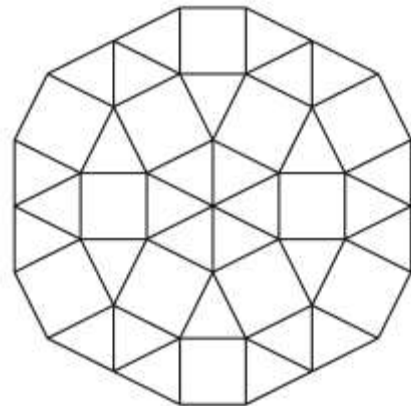

148. Fourteen-Piece Square. When Mary and I were asked to do a puzzle workshop for Elderhostel in Lenox, Massachusetts, in 1999, we needed an easily made puzzle for a handout, hence *Fourteen-Piece Square*. I glued them up in a two-foot-long bundle and then sliced off about 40 of them sausage fashion. If not carefully made (and they were not) they tended to have unwanted solutions, but for a free handout, who could complain?

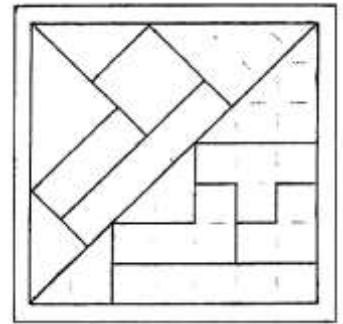

149. Five-Piece Garnet. According to my records, I made two *Five-Piece Garnets* in 1999, including this one in a photo supplied by John Rausch. This odd departure from the usual six piece version may be a little more confusing to disassemble. The solution is indicated by the letters, which are to be matched side by side. Thus one subassembly is 1-2-5, the other is 3-4, and they slide smoothly together to complete the assembly.

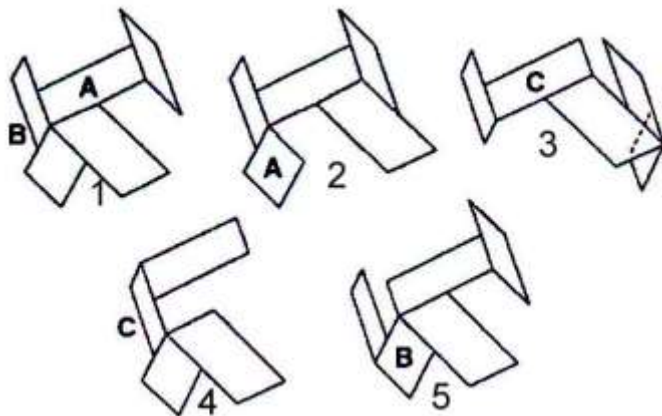

And now I have made another in African mahogany in order to have a photo of the pieces.

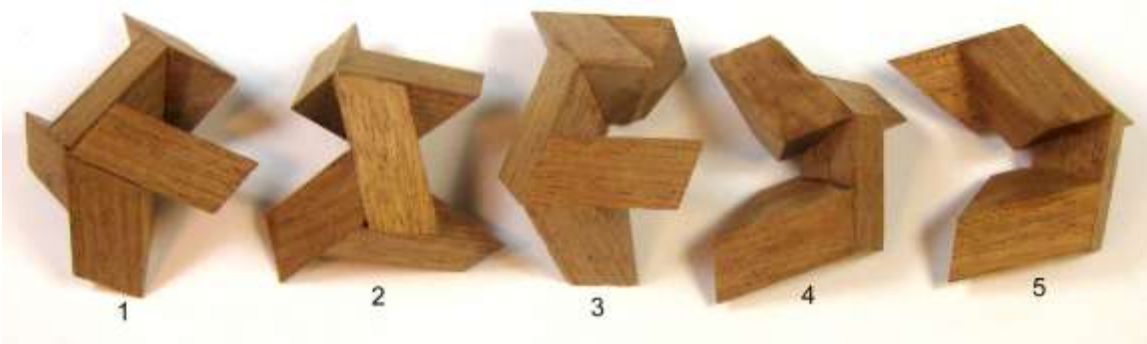

150. Five-Piece Garnet with Coordinate Motion, later renamed Knife Attack! A comparison of the plans for this and the preceding show just one slight different, where one block has been relocated to a different piece. Yet that one seemingly slight change added considerably to the difficulty of assembly and especially disassembly. The 2003 *AP-ART* has a John Rausch photo of me taken during a mini puzzle party in Andover. It shows me trying to pry one apart with a kitchen knife, hence the name change, which was probably John's idea and not mine. All this seems like ancient history now 15 years later, but I certainly remember. My notes say I made only one, but I have now made another of African mahogany to refresh my memory and to photograph. Pieces 2-3-4-5 go unwillingly together by coordinate motion too complicated to describe, possible only if edges are rounded. Piece 1 then goes in last as a sort of key, but not a very good one because it can easily fall out. So on the whole a not very satisfactory design, but one that at least furnished us with some entertainment.

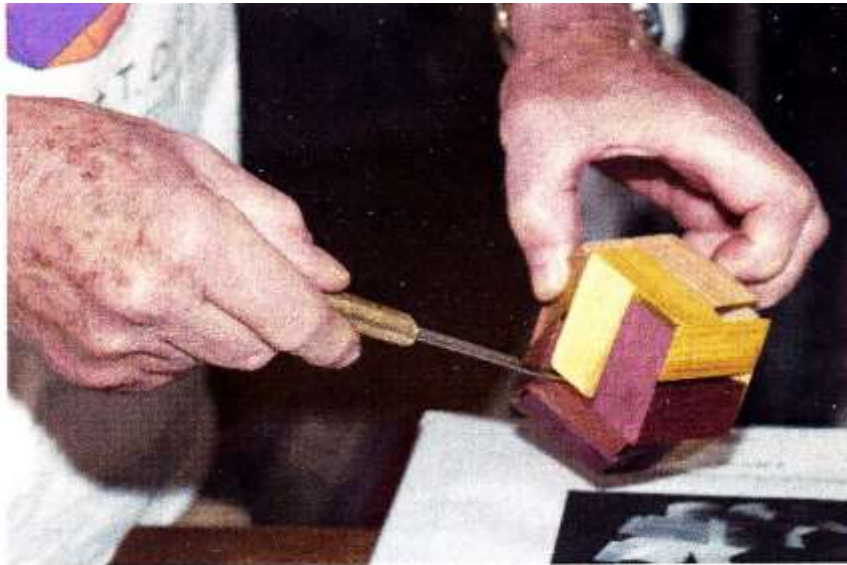

Me, demonstrating how to disassemble the Five-Piece Garnet with Coordinate Motion (#150) and why it is also known as Knife Attack!

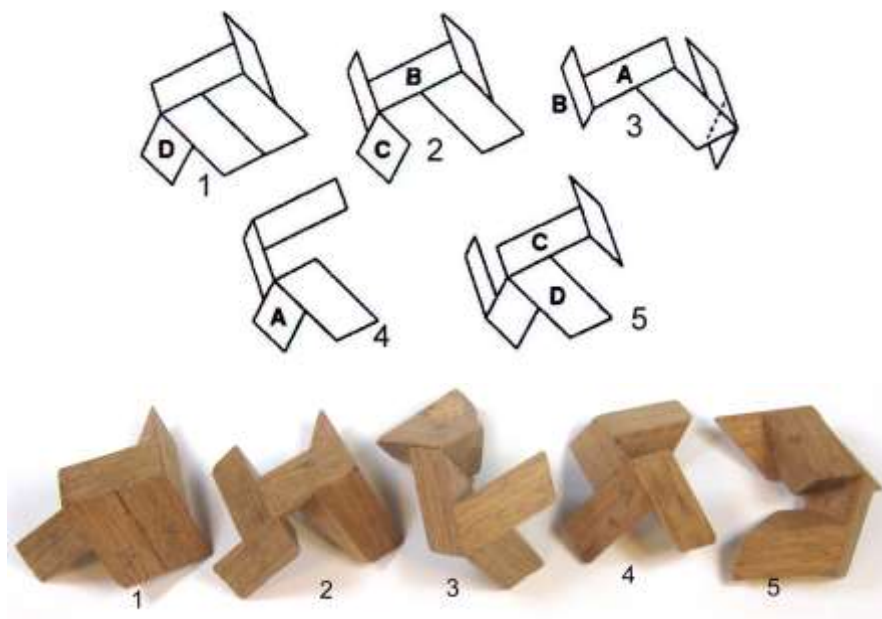

151. Two-Tiers with Scorpius Outer Shell.

This was my third experiment with two tiers (see #75 and #75-A). The innards consist of a *Garnet* #60, and the outer shell is a *Scorpius* #5. It was fun to make but time consuming, so only this model and one other were made in oak around 2000. (But more were made later in the X series. See especially X-14.)



153-A. The Trap. Fiendishly difficult flat combinatorial puzzles are easy to design simply by increasing the number of dissimilar pieces relative to the number of solutions, which can now be determined effortlessly by computer. Much better are those with few pieces that look enticingly easy, but then may not turn out to be. In *The Trap*, four simple pieces fit into a slightly rectangular tray. You might be surprised how few people solve this puzzle. If you are thinking of making one, note that it must be copied very accurately as there are at least seven ways that the pieces almost fit (see below and next page). It took a while to iron out all these details and eliminate false solutions, hence suffix -A.

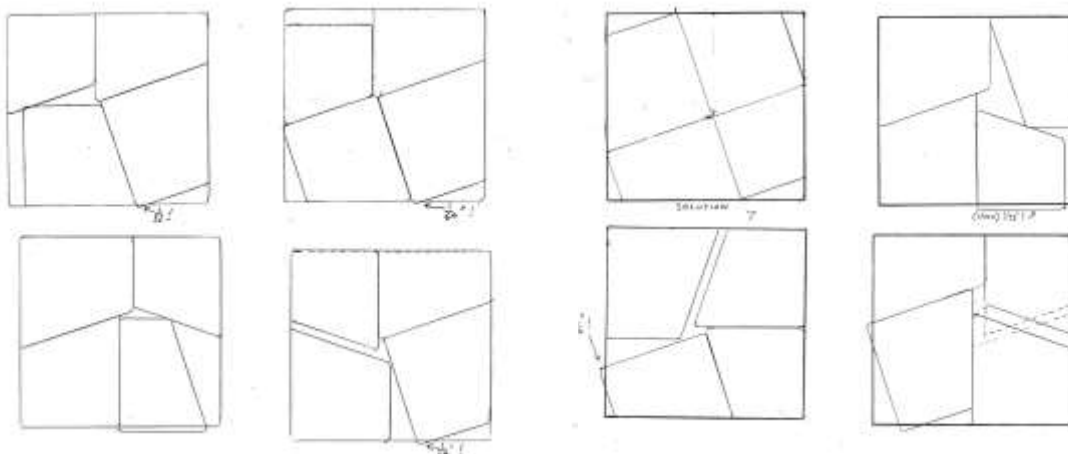

153-B. Please Drop In. Here we have the added novelty of a Plexiglas cover and slot in the side of the tray through which the pieces are inserted. This model is by Saul Bobroff and was used by him for an IPP exchange.

If you make a reproduction, pay attention to these eight arrangements. The top left is the solution, and all the others are ways that should not quite fit. If they do, you have some slight inaccuracy that needs to be corrected. And there may be others I overlooked.

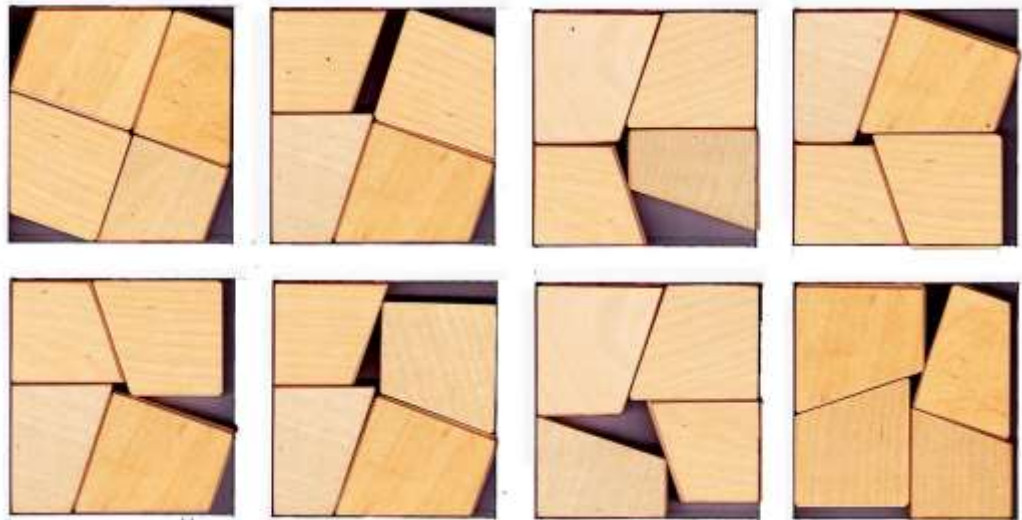

155. Eight-Piece Tangram. The plot behind this one is simple enough. Nearly everyone is familiar with the classic *Tangram*, and especially those experts who attend the International Puzzle Party. So why not throw in an extra small triangle and slightly oversized tray for their amusement. I think it made a quite satisfactory IPP exchange puzzle. Some of the corners are slightly rounded.

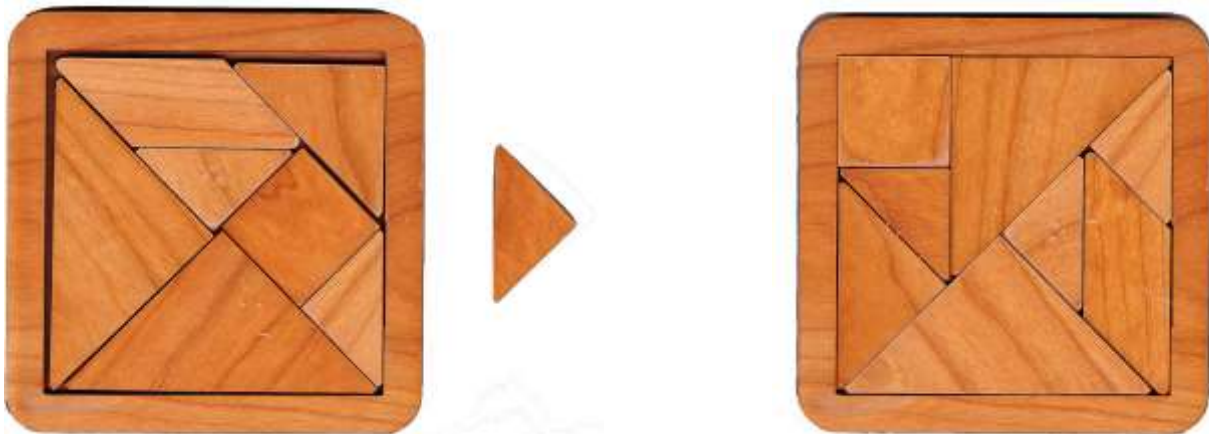

156. Sphinx. I must have used nearly 100 different kinds of wood in my craft at some time or other, some regularly and other sparingly if rare or expensive. In 2000 I designed *Sphinx*, an improved variation of *Saturn* #24, to make good use of some of these fancy woods. Matching the pairs of like woods was an aid to assembly, but I usually marked the pieces and provided instructions as well, since the aesthetic value of *Sphinx*, as with others, depends entirely on being assembled. The basic #156 (right) was in solid walnut, #156-A in six woods, #156-B in 15 woods, and #156-C in 30 woods. I made only a few of each until I started running out of some of the less common woods. The fine 30-wood #156-C shown below was made by Bart Buie.



These are the twelve dissimilar and non-symmetrical pieces for *Sphinx*. It is assembled by matching the letters. The final step is the mating of two halves.

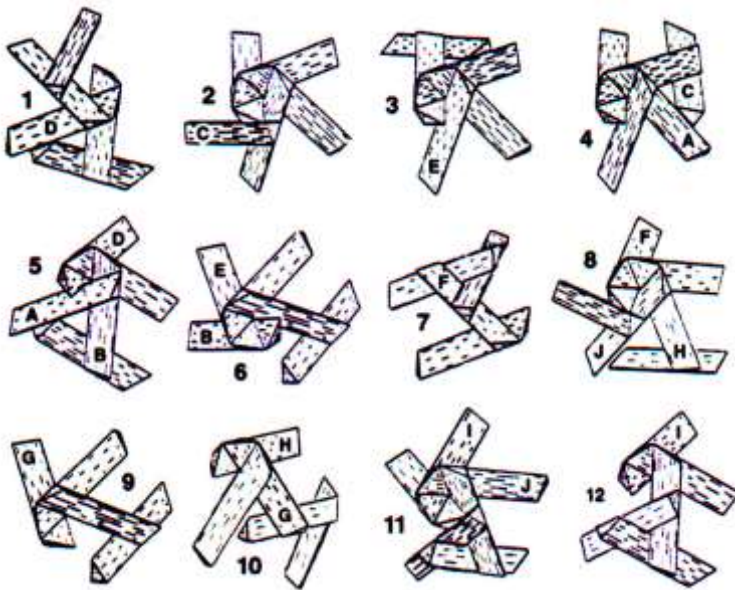

157. Egyptian Plus. As already explained, *Egyptian* #23-A was an oversized *Scrambled Scorpis* #23 with sticks of trapezoidal rather than triangular cross-section. I originally made them in red oak. *Egyptian Plus* is a re-issue but with multiple colorful woods arranged in different ways, usually symmetrically. The first one shown below is in four dissimilar woods, with my commonly used arrangement of all like woods mutually parallel. In the second, a different wood is used for each of the six pieces, making it more difficult.



159. Seven-Piece Hexsticks. In 1995 I got the idea of gluing some of the *Hexsticks* pieces together to make a more interesting puzzle. Paradoxically, as the number of pieces decreases, difficulty increases markedly. The first was *Stucksticks* #70, later followed by *Sticky Sticks* #140. Still seeking the optimum design, in *Seven-Piece Hexsticks* eight standard pieces are joined in pairs to make four T pieces. An odd and standard piece are also joined. It is believed to have only one solution, and does not require any looseness. Description should suffice, so no photo.

159-A. Seven-Piece Hexsticks, All of which we leave behind in favor of this further improved and presumed final version. It has five T pieces, only two of which are alike (lower left). It was assumed to have only one solution until a minor variation of it cropped up. I no longer have some of the woodworking tools I once had, so I laboriously fashioned one model in 2003 using multiple saw cuts. But then along comes this stunning reproduction exquisitely crafted in walnut by Josef Pelikán.

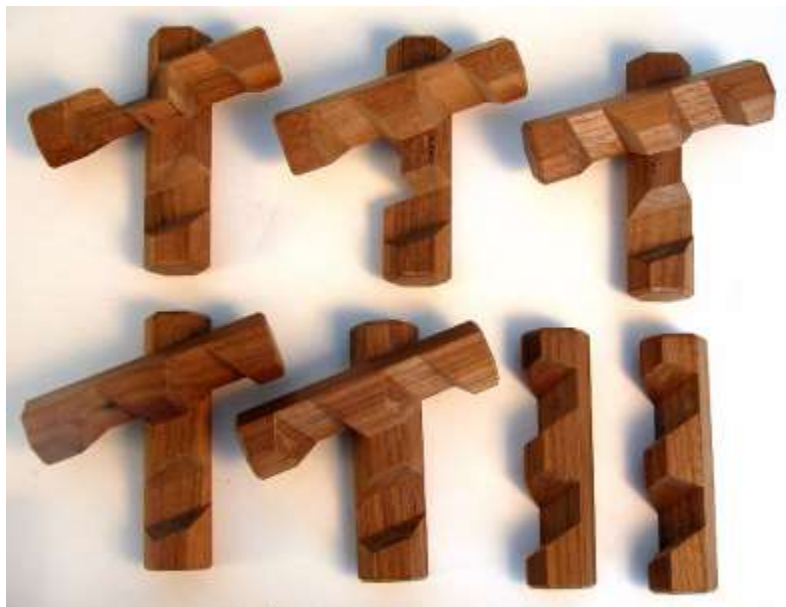

159-B. Seven-Piece Hexsticks. The final version? What could I have been thinking? Sometimes it is the most obvious that is hardest to see. To begin with, the preceding #159 and #159-A were misnamed *Hexsticks* when they both should have been *Hectix*, made as they were with nine standard pieces and three odd pieces. But worse, #159-A has two pairs of identical pieces. It also had three internal voids, which could be considered another defect. All this is easily corrected by filling in those three voids, which at the same time automatically creates all dissimilar pieces. Here again are Josef Pelikán's beautiful walnut pieces. The seven puzzle pieces are made from six standard pieces, three odd pieces with the extra notch, and three pieces having a single notch.

This truly is my final version. As I write this in July 2013, it exists only on paper, for I created the illustration of the modified pieces using Photoshop. The final step of assembly is the mating of two subassemblies. One subassembly is made from the pieces top right, bottom right, and bottom left. The puzzle is believed to have only this one solution, but that remains to be proven.

Now, if only some skilled woodworker will make a few of these, I would certainly like to add one to my puzzle "museum." Without a special custom notching tool, one is forced to laboriously make each of the many notches by repetitive saw cuts.



160. Venus. This was a variation of *Design No. 72*. To disassemble, a key piece first had to be pried loose. It wasn't very satisfactory as a puzzle but perhaps more so as a sculpture, especially when made with multiple fancy woods. Versions 160-A and 160-B used five woods, 160-C used six woods, and 160-D was all one wood. Nick Baxter's two photos are of 160-B.

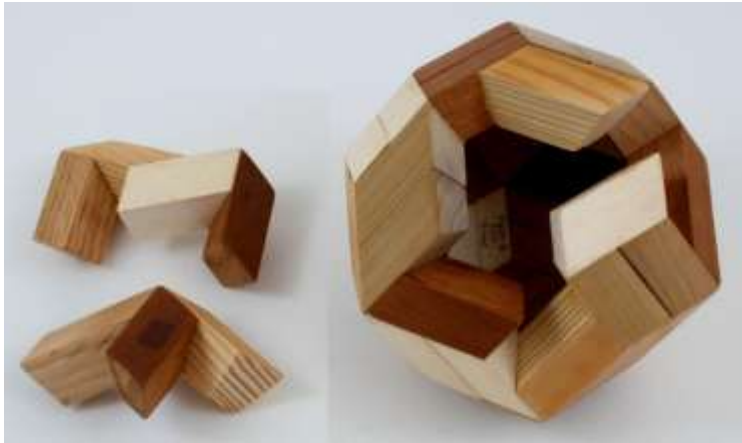

Shown below are the ten dissimilar, non-symmetric pieces for *Venus*. As usual, they are assembled by matching letters.

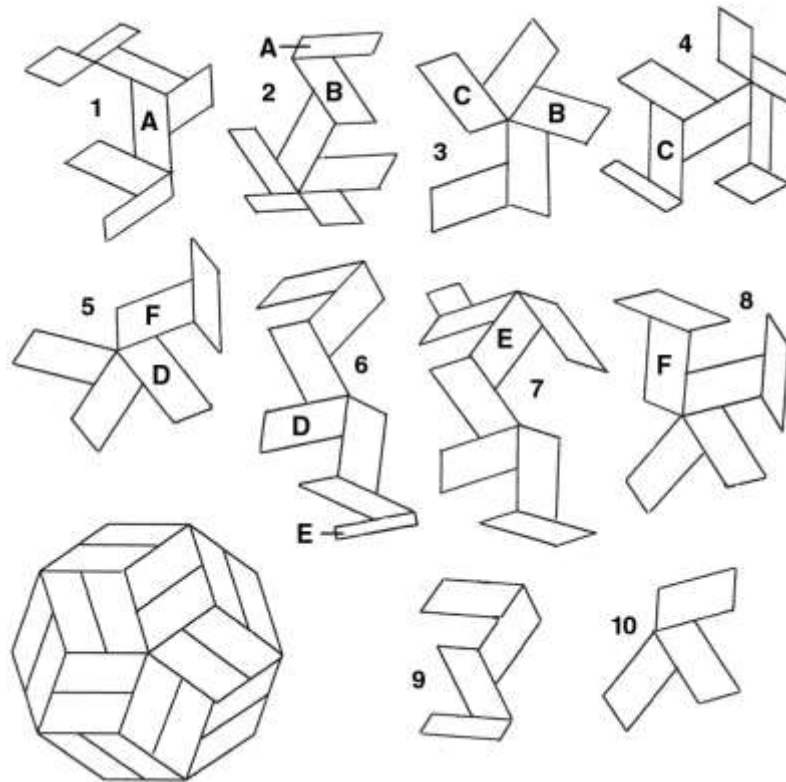

161. Garnet. This is a more accurately made and 20% larger version of the original *Garnet* #60, which was rather on the small side. Looks just like #60, so no photo.

162. Scrambled Legs. In 2000 I was asked to come up with something special for the IPP20 logo competition prize, and the result was *Scrambled Legs*. It has the same solution as *Scrambled Scorpius* but an entirely different shape – the now familiar third stellation of the rhombic dodecahedron. Matching the four colorful woods aided the otherwise difficult solution.



As explained at the start, I am skipping some serial numbers, and those skips will occur more frequently from here on. Some are skipped for being too repetitious or less interesting, or even dismal failures, but even they were included in the complete Serial List in the Appendix of my 2014 *Compendium*. When one has been digging in the same ground for fifty years, new gems become harder to uncover, and even more so as one sinks inexorably into those declining years.

164. Scrambled Scorpius. A reissue in multiple woods. The idea seems so obvious (see #162), not sure why it even needs to be listed, but evidently nearly all that I had made previously were in one wood.

This version uses four woods arranged symmetrically in what I call *Super Scrambled*, no like woods touching.



164-A. Scrambled Scorpius. Here in six woods with one wood for each piece.



164-B. Scrambled Scorpius. Likewise in six woods, but here in double pinwheel symmetry, with no like woods touching.

Nothing really new here. Just having fun with my supply of fancy woods that I love to work with.



165. Split Star, Simplified. This was a fascinating project that brought much satisfaction and is perhaps some of my better woodcraft. The simplest way to explain it, if that is even possible, is to imagine making six *Split Stars* #75, with the inner and outer blocks again joined by half faces. (Yes, I know, probably makes little sense.) I then selectively and symmetrically omitted some of the stellated outer parts. The interesting result was a matching set of six different but related sculptural polyhedra that for good measure are all interesting puzzles. I crafted this one matched set in padauk and satinwood in 2000, which some lucky collector must now own. Perhaps other intrepid woodcrafters will be able to fathom my vague description and make reproductions. These photos (and many others) are by John Rausch.

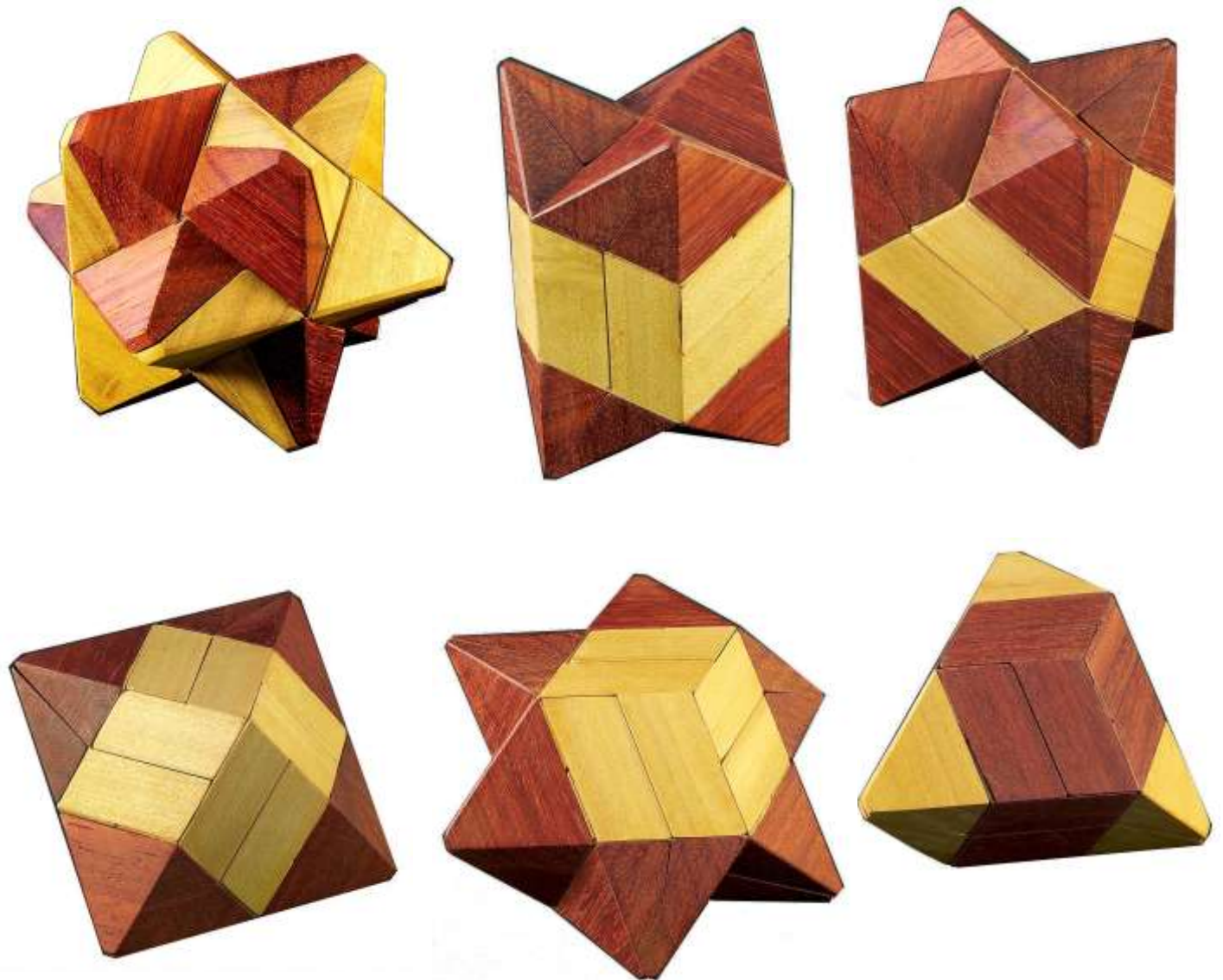

Subsequently I must have made and sold a second set, as these photos of a partial set in canarywood and maple have been supplied by Nick Baxter.



I have also now made a third set in oak and maple that will remain in my own collection. So now we finally get to see what the pieces look like. Here are the six pieces for the fully stellated version. For the other, such as above, just selectively leave out some of the outer parts.



166. Shouldered Scorpion. Like a few others in my *Compendium*, this #166 stands for a whole family of puzzles that all look practically alike but differ in what really matters – mechanical action. All are made simply by adding what might be called spacer blocks to the old *Scorpius* #5. The added parts are seen in these photos as dissimilar wood. In what I call the *Simple Version* #166, the shoulders restrict movement in the first step of disassembly to separation into two identical halves along one axis only. Pieces for one half shown.

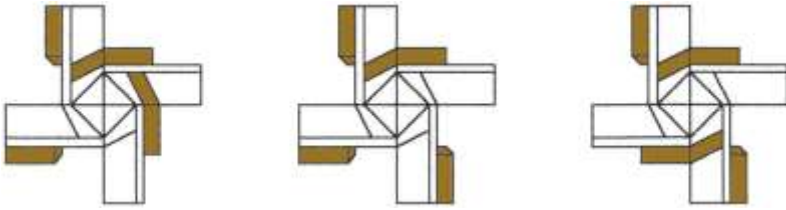

166-A. Shouldered Scorpion. The *Three Plus Three* version. Here all six pieces are identical but non-symmetrical. The tricky solution involves coordinate motion. It is shown both together and starting to come apart.

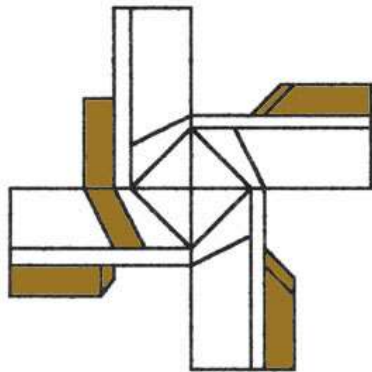

166-B. Shouldered Scorpion. The *Symmetrical Version*. Here all six pieces are identical and symmetrical, and the solution again involves coordinate motion. Careful inspection of the photos will show that the shoulders can be attached either one of two opposite ways on any one of the four arms of each of the six pieces, and may be cut to separate from each other along either a three-fold or four-fold axis. There must be a great many possible ways of combining all these variables, and rather than go into more design details I leave to others the fascination of exploring the many interesting possibilities.

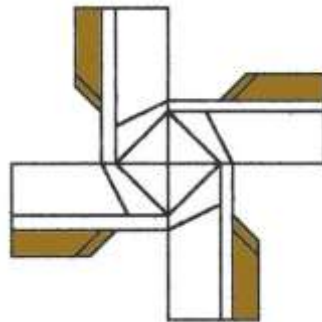

167. Cruiser. This little gem is a sequel to *Few Tile* #133 and a top favorite among my flat tray puzzles because of its deceptive simplicity. Fit the two trapezoids and two triangles into the rectangular tray. Mary and I would take one along on our various travels to entertain our companions, hence the name. Seldom could any of them solve it. Then we would start dropping hints: “Do not fit pieces snugly into the corners of the tray,” but to no avail. When we did show the solution, there were usually a few who would complain: “But you didn’t tell us there would be empty spaces.” It is an easy one for the reader to copy and make out of wood or cardboard and does not require great accuracy.

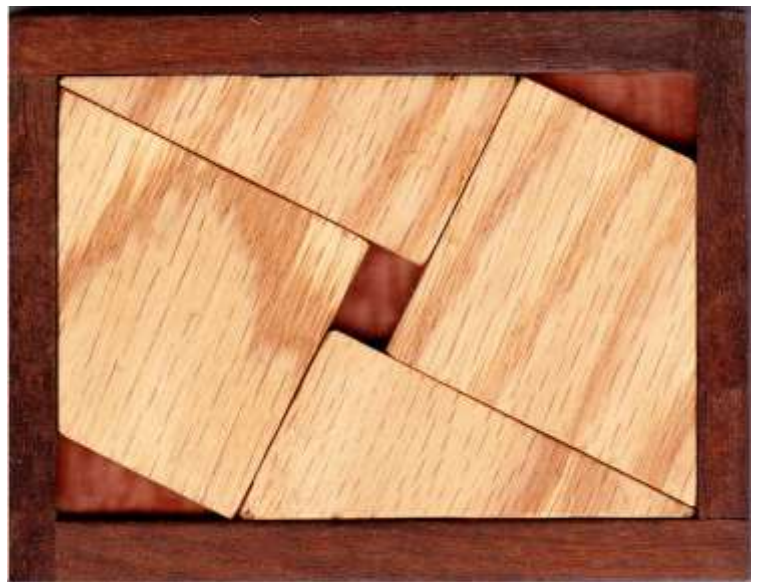

I suppose it sounds self-serving to highly rate my own puzzle designs. My excuse for doing this is that it gives some indication which ones I most recommend for woodworkers to reproduce, and also which ones might be a good choice for exchange or manufacture. An IPP Exchange.

168. Colorful Cornucopia. This was a reissue of *Cornucopia* using ten dissimilar colorful woods (or twelve if you also count the corners and tray).



173. Hexcuse Me. The six dissimilar non-symmetrical pieces fit into the hexagonal tray leaving two empty spaces. I assumed my solution to be unique, and this was later confirmed by Mike Beeler. This puzzle exploits the natural tendency to first place the long pieces touching three sides, but to no avail. The two empty spaces (dark) create further confusion. This reproduction was laser-cut by Walter Hoppe.



177-A. Five Woods. In case you haven't already discovered, *polyominoes* is the name given to puzzle pieces made of squares joined different ways. A popular recreation is to fit them snugly into a square or rectangular tray. The long-time popularity of this pastime opens up opportunity for puzzle makers to exploit it by surreptitiously deviating from the regular grid. In this puzzle, all pieces are rotated by $\arctan \frac{1}{2}$, which is 26.6 degrees. With two pieces alike and two symmetrical it is not as difficult as some others, but an entertaining pastime and quite nice to contemplate and play with when made in five colorful woods. The flatness makes possible bringing these woods to a fine finish on the belt sander. The second model is made of redheart, yellowheart, mahoe, oak, and poplar, with rosewood tray.



178-A. My One and Only. I include this seemingly mundane puzzle design to show that there is still room for discovery within even this most common category of dissecting the plane - what I call "graph paper" puzzles. The problem here was to find a combination using the five non-symmetrical pentominoes (made of five joined squares) plus one other pentomino that fit into a rectangular tray one way only. After a long search, this goal was finally achieved. Then, using an amazing computer program called PuzzleSolver3D, I had the satisfaction of confirming that I had discovered the one and only combination that met all of my requirements. Try to top that if you can.



But there is more. Pleased with this lucky discovery, I generated a catalog of about 20 other symmetrical problem shapes, some with unique solution. Three are shown here, and the others are left to be rediscovered or improved upon.

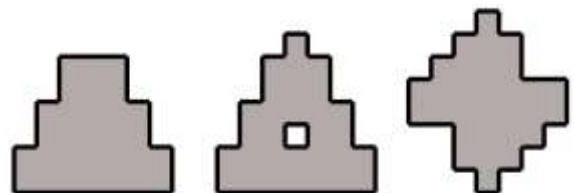

181. Sunrise-Sunset. This puzzle started out as just five colorful polyomino pieces that fit into a 4x6 rectangular tray one way only, but it evolved over the years into a version with a two-sided tray that is square on the other side. One of the many simple problems is to find the one solution with the empty hole in the center of the square. An IPP exchange.

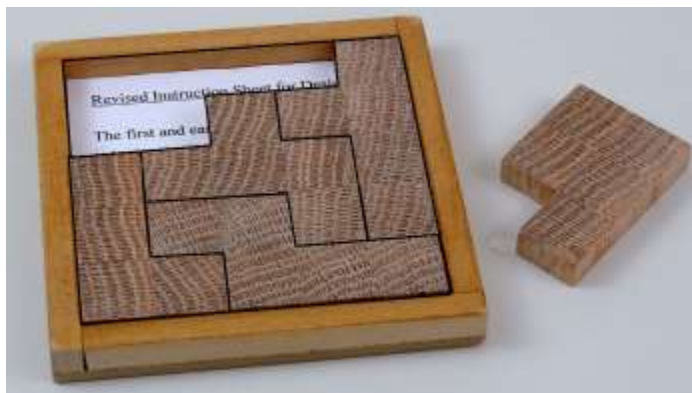

These same five pieces are also used for *The Castle* #181-A and *Vanishing Trunk* #181-B. Each of these came with its own set of additional problem shapes. Since they can be applied to all three, a dozen of them are here lumped together. The number of solutions is given. But wouldn't it be more fun to discover your own rather than copy mine?

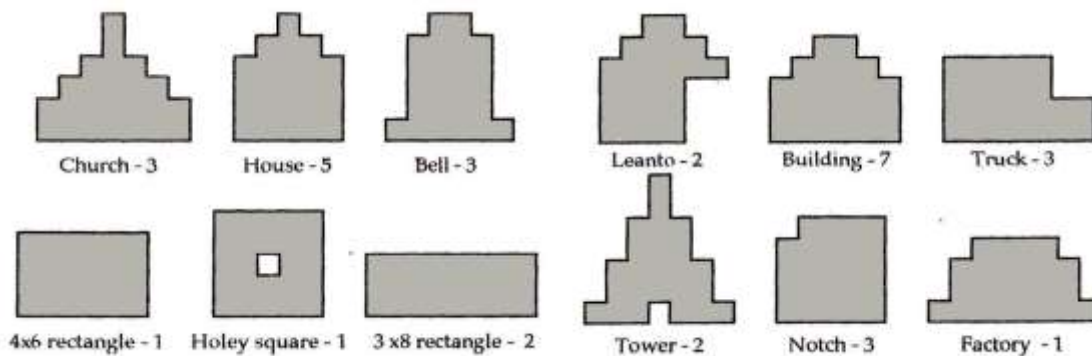

181-A. Castle. This version uses the same set of pieces as the preceding but a different two-sided tray. On one side the castle has a chimney, but on the other side with nearly the same size and shape of tray it mysteriously disappears.



181-B. Vanishing Trunk. In this version, again with a two-sided tray and the same pieces, on one side the tree has a trunk but on the other side it disappears. Note that the other side has been recycled from the *Castle*.



181-C. Housing Project. As you can see, for a while I took a special interest in puzzles having a two-sided tray. *Housing Project* comes with its five pieces neatly assembled on one side of the tray, and the problem is to reassemble them on the other side that looks the same but has slightly different dimensions. The other side of the tray comes up automatically when you dump the pieces out of the first side. Again the not so obvious solution requires rotating all the pieces by 45 degrees. This last one is my favorite of the three in this group. For one thing, the tray is simpler and easier to make. An IPP exchange.

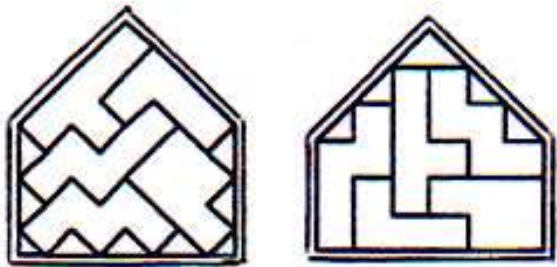

182. Christmas 2001. It didn't take long for puzzle fans to catch on to the 45-degree rotation, which has also been exploited by others, or even the less common 26.6 degrees of #177-A. So the next step was to change the angle again to $\arctan 1/3$ or 18.4 degrees. I present this puzzle with apology because I prefer not to issue puzzles of this type that are extra difficult (believe it or not), and non-symmetrical as well. Friends usually expect the solutions of my puzzles of this type to be symmetrical, but this one isn't. But it's most vexing feature is that not a single one of the pieces rests comfortably by itself in a corner, or even along a side, so how do you begin? I made just a few of these during one holiday season (hence the name) as gifts to puzzle experts, who I hope will forgive this departure from what I consider the rules of the game.



The original Christmas (top) has two design flaws- a piece duplicated and a symmetrical piece. Both flaws have been corrected in this revised 2018 version (bottom). Both versions have only one solution.



Here is some serious food for thought. The main challenge in designing puzzles of the sort shown on the preceding four pages is making sure that only the one intended solution exists. With more than three or four pieces it can become very difficult to determine for certain. I do not know of any way except judiciously and perhaps systematically trying by hand every possible regular or irregular arrangement, and even after all that you are left with lingering doubts. When unintentional solutions occur with the pieces scattered all about, often at odd angles, I call them *incongruous solutions*.

Bill Cutler now has a computer program that will sort through billions of possible positions and either find one or more incongruous solutions or indicate that there probably aren't any, nevertheless still falling short of mathematical certainty. So now I wonder if there is a mathematical proof that the answer cannot be determined with certainty, or if such a proof is conceivably even possible. So that raises the question of whether there can be a mathematical proof that something can be neither proven nor disproven. And so on! When I raise this question with friends, some of them think I am just playing word games, but these seem to me like perfectly sensible questions, with possibly deeper ramifications in mathematical logic.

184-A. Looking Glass. The drawing shows the six dissimilar pieces assembled. Some steps involve rotation. *Looking Glass* has a clear plastic cover and a slot in the side of the tray through which the pieces are inserted. A round hole in the cover allows the pieces to be easily moved about with an eraser. An IPP exchange.

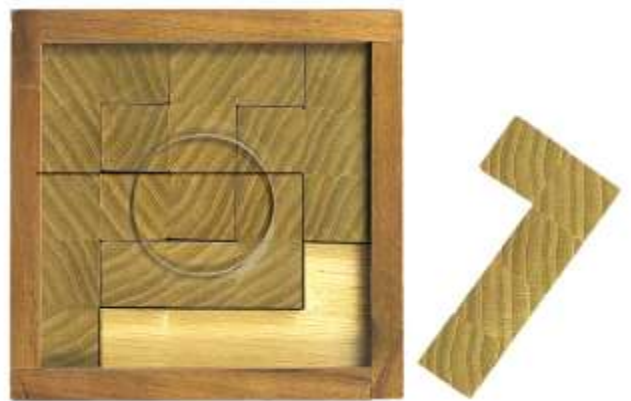
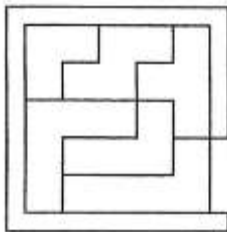

185. Slot Machine. Try your luck on this one - or test your patience! The seven polyomino-type pieces of *Slot Machine* are inserted through the 1x2 slot in the clear plastic cover of the 3x3x3 box, but not without some difficulty. An IPP exchange.



186. Window Pain. For a description of this puzzle, here is a photo and scan of the instruction sheet. Not visible in the photo is the 2-unit side slot (see #184-A).

Window Pain
design 186

This puzzle consists of six polyomino pieces and a two-sided tray.

Problem 1: Assemble the pieces on this side to form a 5x5 square. There are 12 solutions. How many can you discover? One is shown:

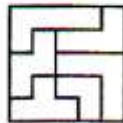

Problem 2: Now turn the tray over and assemble any or all of these solutions on the other side, making use of both the top opening and the side slot. All 12 are possible. For a starter, try the one shown above.

Problem 3: Assemble without using the side slot. Difficult - there is only one way.

Problem 4: Assemble using **only** the side slot. Most difficult - again there is only one way.

STC - 2002



187. Double Play. All three puzzles in this next family have a two-sided 5x5 tray and Plexiglas cover with one or more openings through which the polyomino pieces are dropped and then shifted about. One can practice finding solutions on the side without the cover, for whatever little help that might be. The two solutions to *Double Play* both require 24 moves. They involve coordinate motion, and some corners need to be slightly rounded. The openings in the tray are shown shaded. Here again is a scan of the instruction sheet.



Double Play
design 187

Practice exercise: Assemble the six pieces on this side to form a 5 x 5 square. One solution is shown. Eleven others are possible. How many can you discover?

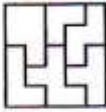

Now turn the tray over and assemble on the other side. There are two solutions. In the first, the key moves require only rectilinear shifting of the pieces. The second is more complicated, involving coordinate motion, and is why the corners of the pieces are slightly rounded. Can you discover both solutions?

STC - 2002

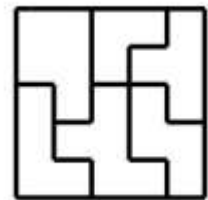
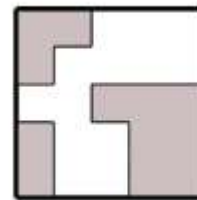

187-A. Decoy. This is my favorite of the three. The L-shaped opening does not enter into the solution, hence the name. But it is helpful for shifting the pieces about with an eraser. Some of the tricky moves are counter-intuitive. Either all corners need to be slightly rounded, or the tray made about 2% oversized, especially for step 4. This reproduction has been beautifully crafted in rosewood by Eric Fuller.



Here is my complicated solution. Perhaps someone can discover a simpler one. (But I doubt it).

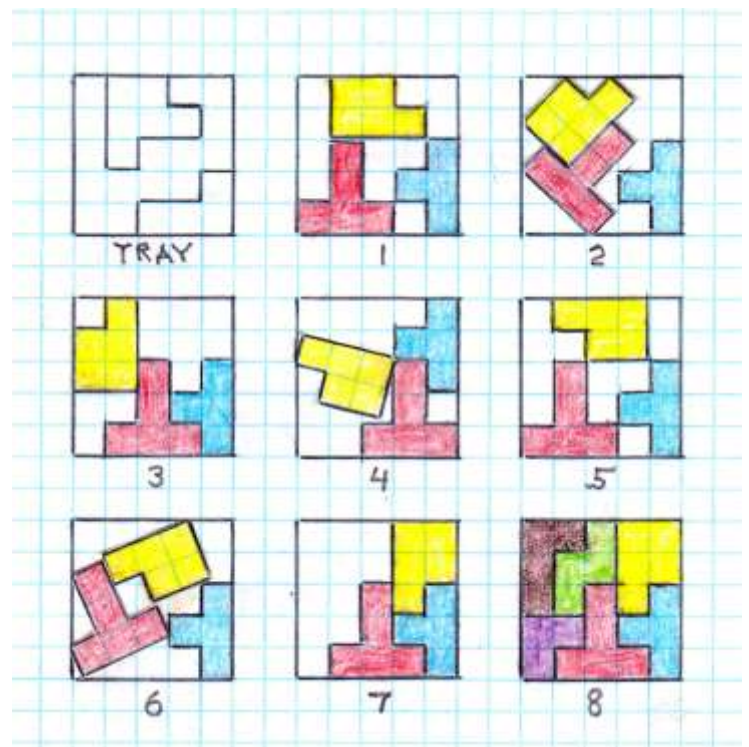

187-B. Fourteen Steps. Yes, that is the number of steps in the solution. It is easier than the two others. The pieces need to fit tightly in the tray or there will be even easier solutions.

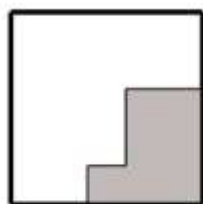
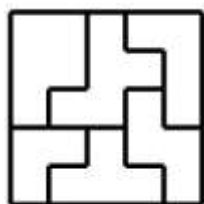

188. Split Box. The five solid polyomino puzzle pieces assemble into a 4x6 rectangle one way only, into a 3x8 rectangle two ways, and into its 2x3x4 box four ways. The two halves of the tricky box are held together with a rubber band, as it converts from a 2x3x4 box to a 4x6 tray. Inverted it forms a 3x8 tray. (In retrospect, a crazy idea - too complicated. See next.)



188-A. Amelia's Puzzle. Same pieces as #188 above but five colorful woods in a simple 2x3x4 box with sliding cover. As usual, simpler really is better. There are four solutions. (Amelia is my granddaughter.)



189. Four Blocks in a Box, or LUV. What could be simpler? Four polyomino-type pieces pack into a rectangular box one way only, allowing the cover to slide shut. Must be accurately made, but quite a neat little puzzle when it is. Jerry Slocum devised an improved cover and used it as an IPP23 exchange puzzle, renaming it *LUV*. The top photo shows the puzzle as presented with one piece projecting through the slot in the cover, the second photo shows the solution, and the third photo shows the four simple puzzle pieces. The model shown is a reproduction made later.



190. Arm in Arm. Four dissimilar pieces, one of which is the key, clasp together in each other's arms. I list this as an improved version of #86. The pieces of both versions are shown below for comparison.



PIECES OF #86

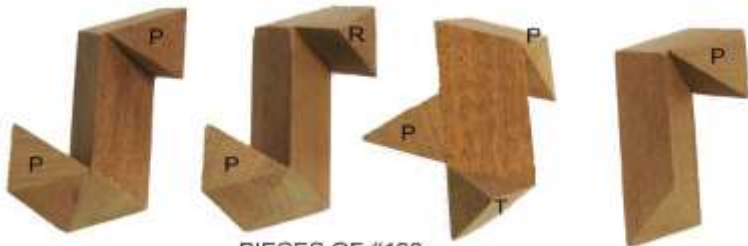

PIECES OF #190



191. Chicago. So named because it was introduced at an International Puzzle Party in Chicago in 2003. It has right-angle cuts for the end blocks, which I think makes it a neater and simpler design than some of the earlier versions such as *Cluster-Buster* #47, *Truncated Cluster-Buster* #48, *Improved Cluster-Buster* #49, and *Cluster's Last Stand* #119, but with the same baffling mechanical action of assembly. It is obvious where the pieces are supposed to go, but the problem is how to get them to behave and cooperate with each other on the way there. Photos show it assembled and partly opened. For photo of individual pieces, see *Polly-Hedral* #206.

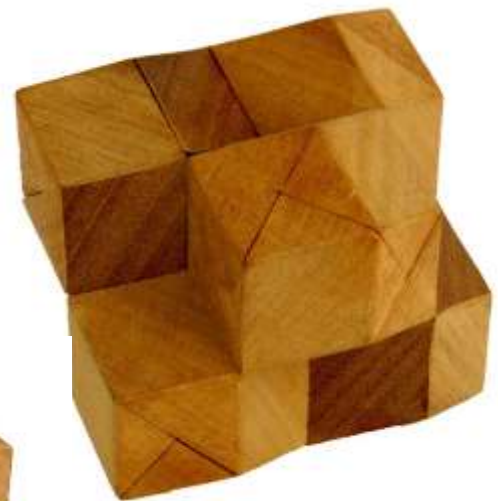

192. Prism Cell. Since I was unable to find a model of this one to disassemble and photograph, I was forced to reinvent it, relying on some sketchy construction notes that read: "Make ordinary *Four Corners* #6 using the usual 12 right-hand prism blocks. Then add 12 left-hand prism blocks of a different wood." I believe I got it right. The 12 added blocks are permuted every possible non-symmetrical way, as in *Super Nova* #14. It is an easy puzzle to make but difficult to solve, and tricky even to disassemble. Woods are poplar and walnut.

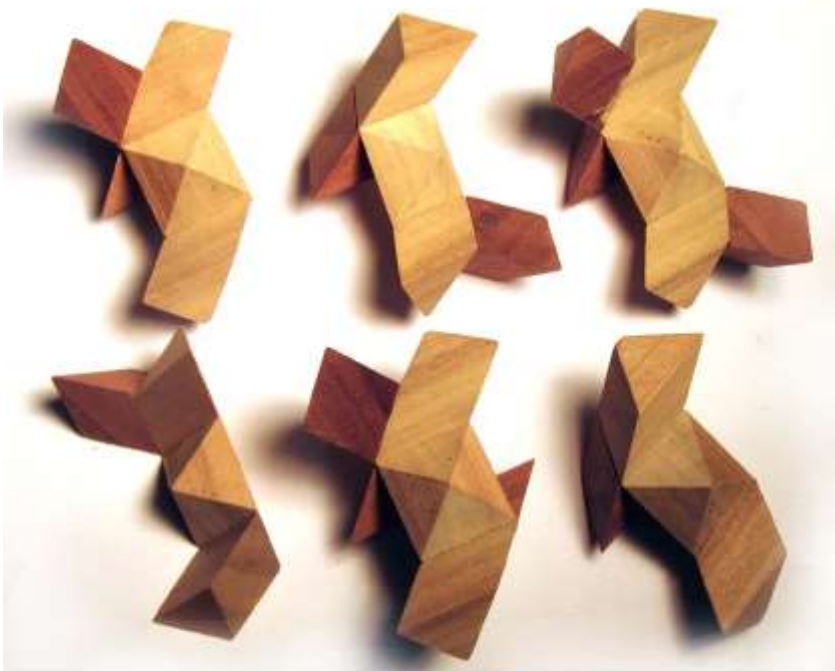

193. Computer Killer. Five polycube pieces, including one with a hidden swivel joint, form a 3x3x3 cube. The idea was that those who resort to solving by computer might suspect computer malfunction or foul play when it failed to find a solution with the secret swiveled piece turned the wrong way. Coming up with that idea was perhaps not one of my better days. The first photo shows the five pieces with the one at upper left turned the wrong way; the second photo shows those pieces assembled with one block projecting from the top; the third photo shows the piece on the left readjusted correctly; and the fourth photo shows the puzzle solved. This is a revival of design 78-B but with the addition of the box and clever way of initially packing. See 78-B for construction of the swivel joint. An IPP exchange.



194. Triple Play. In my 2014 *Compendium* I dismissed this one with just these words: “See *Box Rebellion* next, which is an improved version.” But then I decided to include in this edition at least a photo and brief description. Upon removing the pieces for the photo from one on loan from Margie, I had some trouble getting them back in. I have little patience in trying to solve my own puzzle designs when there are more pressing things to be done. So I consulted some files and found a clever second solution by Margie, which to my astonishment did not require the slightly wider box.

The four identical **L** pieces are each made of three cubes. My original *Triple Play* box was nominally 3 units long by $\sqrt{5}$ wide, and 2 units deep. The slight extra width allowed a piece to be rotated while lying flat. The sliding cover on top about 1.6 units wide is what turns it into a real puzzler. The name *Triple Play* came from the three known solutions, the third coming from Bob Finn. But with Margie’s solution the box can be shrunk to 2x3x2, with presumably only one solution. Accordingly I am calling the improved version *Margie’s Marvel* # 194-A.



194-A. Margie’s Marvel. In addition to reducing the width of the box, I have replaced the thin plywood cover with clear plastic, still 1.6 units wide. Another improvement - round holes at both ends for ease of poking the pieces about, for this was never intended to be a test of dexterity. Margie suggests that adhesive tape can be used when inserting the second piece in order to lift and slide it into place on top of the first piece. The photo shows both pieces in place. The rest is easy.

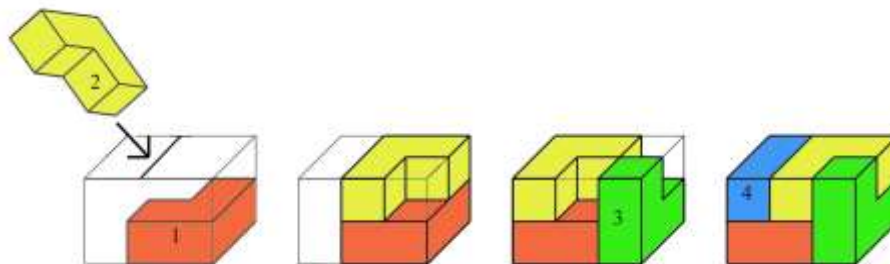

195. Box Rebellion. Four identical L-shaped pieces fit inside a 2x2x3 box through a slot in the tricky acrylic cover that slides back and forth. How could anything so simple be so confusing to assemble?

The acrylic cover has an irregular shape and restricted range of movement, too complicated to describe here. But this was an IPP exchange puzzle in 2004, so there must be plenty around for anyone wishing to make a reproduction. My original solution involves 26 moves, but John Rausch has submitted one that requires only 19.



196. Tray Bien. This is an improved and expanded version of *Quadrilateral* #87-A, with 25 quadrilateral problem shapes to be solved. See if you can not only solve all 25 of them, but better still, explore for any additional quadrilateral solutions that I may have overlooked. Since many of the problem shapes differ from each other only slightly, accuracy is required in sawing out the pieces and laying out the problem shapes. The model shown was very accurately laser-cut by Walter Hoppe.

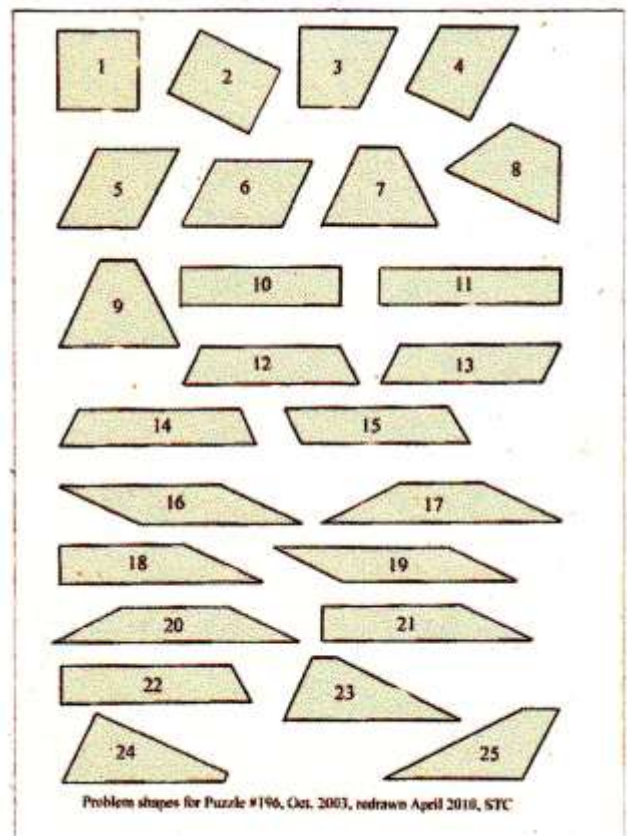

197. Under Cover. This is a variation of *Pyracube* #19, likewise with edge-beveled cubes. The four pieces pack into a cubic box, make a square pyramid pile that fits in the cover, and with one piece left out form a tetrahedral pile.



197-A. Ball Room. This is a variation of *Under Cover* #197 using balls instead of edge-beveled cubes, but otherwise same as the above.

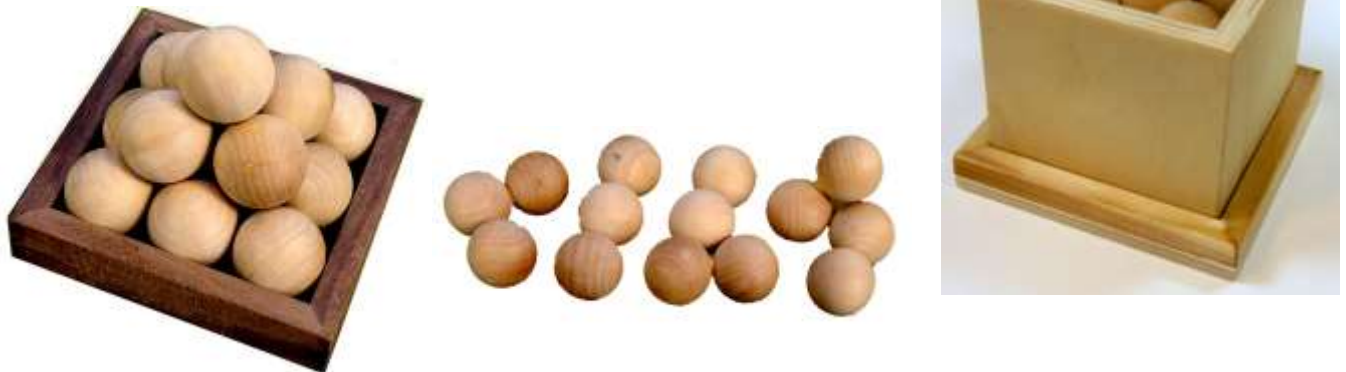

197-B. Sliding Cover. This is a variation of the above, made by equipping the box with a sliding acrylic cover, just barely wide enough to permit assembly. In my version, designed for maximum difficulty, the balls are one-inch, the box $2\frac{1}{2} \times 2\frac{1}{2} \times 2\frac{9}{16}$ deep, and the sliding cover is $1\frac{7}{16}$ wide. With the first three pieces in place, the right-angle piece is shown ready to drop in to complete the assembly. Is that helpful? With this puzzle, you may need all the help you can get. By the way, design of this puzzle involved considering every possible cubic solution of the four pieces, and then every possible orientation of each, before finding just this single one that met all the requirements.



197-C. Contrary Cover. This final one in the series may be even more puzzling than any of the others. The balls are again one-inch but the pieces are different. The box this time is a 2.500 cube. The partial cover with slanted undercut just barely allows assembly. The right-angle piece goes in first on the bottom. The next two pieces go in by mutual cooperation, with the piece shown outside going in last. Slide the cover on to complete the conquest.

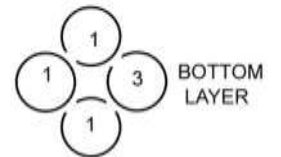
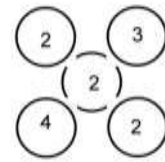
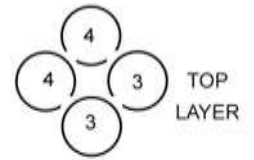

198. Involution. This is a slightly revised version of *Convolution* #30. (It later underwent further revision to become listed as *Involute* #214.) It is serially interlocking, and the numbers indicate the order of assembly. The key piece 7 is shown shaded.

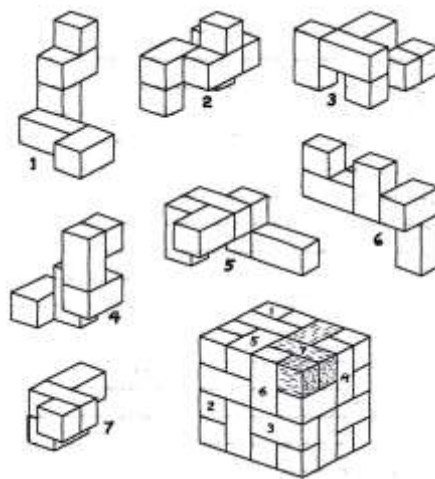

199. Blocked Box. Six polyomino pieces fit into a 3x3x3 box that has a cubic block attached to the top midpoint of one side, hence the name. It was presumed to have only one solution, but I was never sure until Bill Cutler confirmed it by computer. This model was made by Henry Strout for use as an IPP25 exchange puzzle.

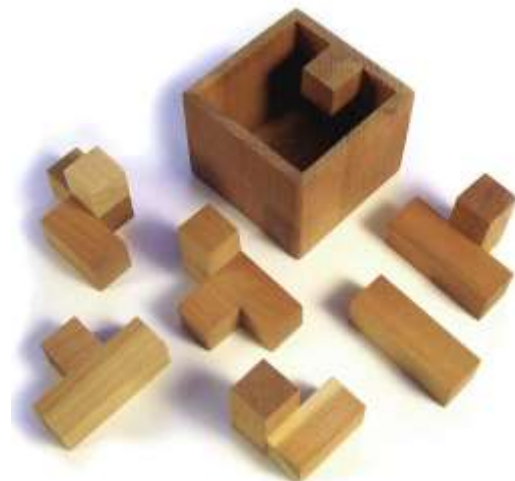

200. Fancy That. This puzzle has the same external shape as *Fancy This!* #115, but with different and fewer pieces. It is fairly easy to make, with its six center blocks, twelve triangular stick segments, and 12 right-handed prism blocks. For assembly, see #200-A.

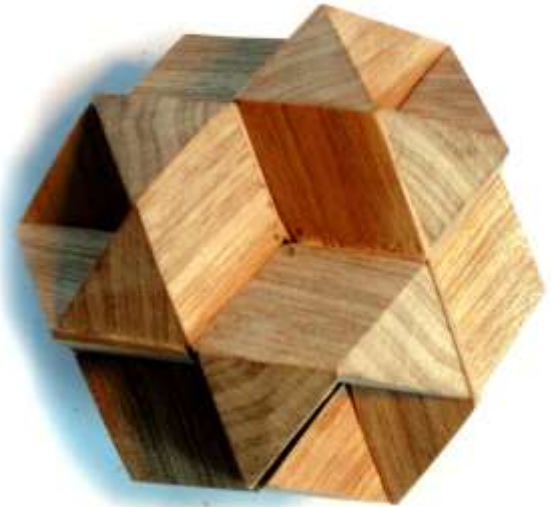
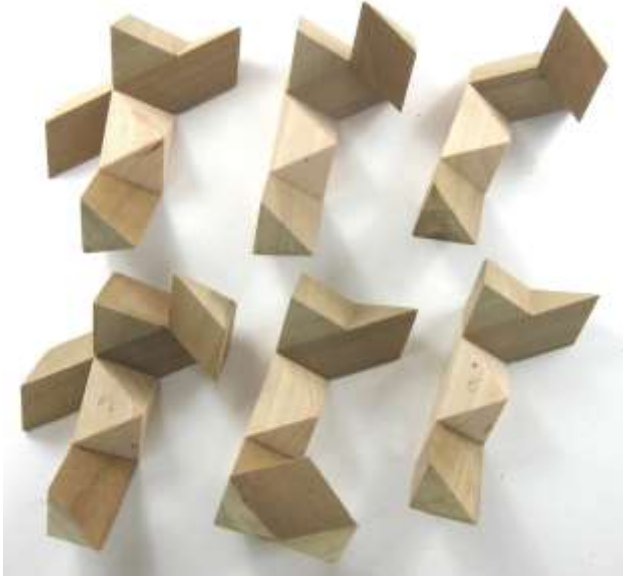

200-A. Fancy That. This stellated version is similar to the preceding but with longer arms, giving it the shape of the third stellation of the rhombic dodecahedron and making it slightly more difficult to assemble. I made only a couple of each of these in 2004, this one in canarywood. Design is similar to #200. Just make the triangular segments longer. As usual, the last step of assembly is the mating of two halves. The top three pieces form one half, the bottom three the other.



201. Victor. It has the same external shape as #200, but with different insides. It can also be regarded as the *Combination Lock* #128, modified to have polyhedral symmetry by lengthening some parts. Assembly involves coordinate motion of all six dissimilar non-symmetrical pieces. As at least some aid to the difficult assembly, the pieces are marked R-E-D-S-O-X. To assemble, form a subassembly of pieces R-E-D clockwise. Then insert piece S opposite D, then O opposite R (only place it can go). To insert the last piece X, carefully expand the monster almost to the point of collapse and very carefully wiggle X into place.

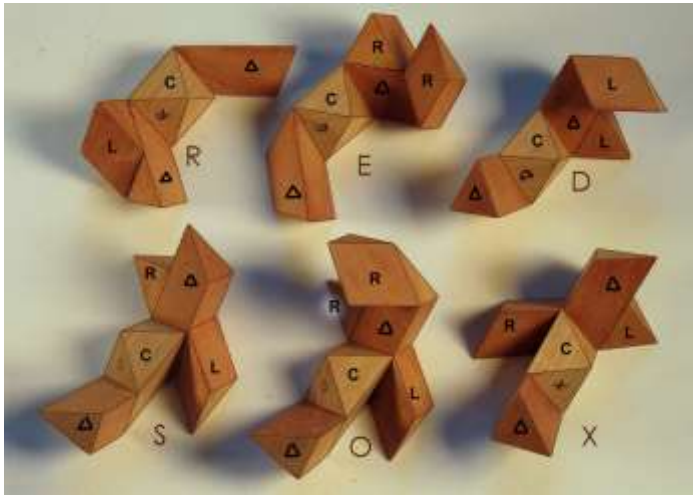

201-A. Victor. This is basically the same as #201, but with longer arms, giving it the shape of the third stellated dodecahedron and making it somewhat more difficult to assemble. This canarywood model is first shown assembled, then expanded almost to the point of collapse, and finally in pieces laid out in order of assembly. These pieces are likewise marked R-E-D-S-O-X, and the assembly directions given for #201 apply to this version also.

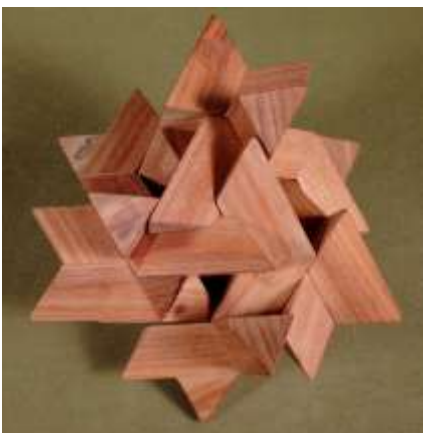

202. Drop Out. For a while I became interested in the so-called sliding block puzzles, which I suppose don't really belong in this book since they don't usually come apart. But my favorite design, *Drop Out*, actually does come apart and so happily gains admission. The one square and four rectangular pieces slip and slide merrily around inside the rectangular tray with transparent cover. The round disk (ceramic magnet) is dropped in through a hole in the cover at one end, and the problem is to allow it to drop out the bottom hole located symmetrically at the other end. The smaller center hole is just for access to move the pieces about. It requires 26 moves, some of which are counter-intuitive when the disk is moving away from its goal. But the real fun begins when you hand it to someone already partially solved and let them easily finish it. "Nothing to it," they say. "Oh sorry, I wasn't watching. Could you please do it again?" So they drop the disk into the hole, and they can then shift the pieces back and forth until kingdom come without ever solving it because the other pieces got rearranged in the process. They must be restored by eight moves to their original positions as shown before starting again. Pretty neat, I thought. An IPP exchange.



203. Square Route. Since sliding block puzzles fall somewhat outside my definition of AP-ART, I include these next seven with only brief mention. The number of moves was determined by an amazing program called SPBSolver. The number will vary depending upon one's definition of just what constitutes a move. *Square Route* requires 82 moves to get the tulipwood rectangle from upper left to lower right.



203-A. Multiple Choice. This one is similar to *Square Route* but with grid distorted from square to rectangular (for no good reason that I can think of now), and with multiple problems presented on its accompanying instruction sheet. This model is in tulipwood and teak.

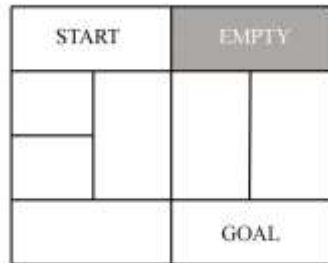

203-B. Sunrise. Same idea as 203-A but with bands of color to be rearranged. Instruction sheet is pasted in.

Castle Creations Design No. 203-B

Sunrise

The starting position of this sliding block puzzle is with the two horizontal dark blocks at the top, the three vertical reddish blocks and two small ones in the center, and the one light horizontal block at the bottom. The object is, by shifting the blocks about, to reverse the colors so that light is on top and dark on the bottom. The five reddish center blocks may end up in any order.

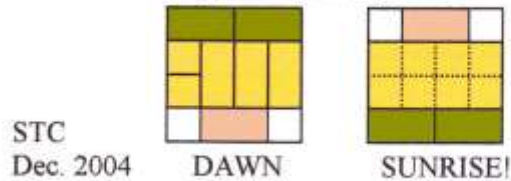

203-C. The Fox. This one is similar to *Square Route* but with the scrambled head of a fox on blocks 4, 5, and 6 requiring a makeover. Photo of Fox is presently missing, so use your imagination, or better still substitute another image of your choice.

With the 120 moves required, who would ever have the time and patience for tasks like these? But that misses the point. They are fun to design. Challenge for those so inclined: Is 120 the upper limit for puzzles with these eight simple pieces? If not, what is?

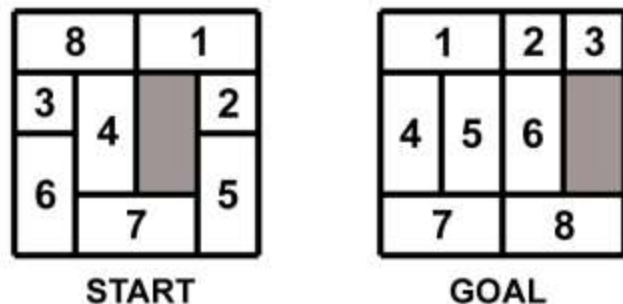

203-D. Helsinki. Twenty-nine moves are required to reconstruct the flag of Finland and “Helsinki, IPP 25.”



203-E. Monarch. It is similar to *Helsinki*, but here 39 moves are required to unscramble the monarch butterfly and larva to the finished position shown. The peg and eraser fit together as a tool for moving the pieces about.

Solution to Castle Creations #203-E, The Monarch

1. 3 L	11. 2 RD	21. 4 R	31. 4 R
2. 6 RD	12. 5 D	22. 6 D	32. 1 D
3. 5 RD	13. 6 D	23. 3 LU	33. 5 L
4. 4 L	14. 1 R	24. 4 UR	34. 4 U
5. 2 DL	15. 4 U	25. 6 U	35. 1 RD
6. 6 U	16. 6 LU	26. 2 L	36. 6 R*
7. 5 R	17. 3 UR	27. 4 D	37. 5 DL
8. 2 D	18. 4 D	28. 5 D	38. 4 DL
9. 6 L	19. 6 L	29. 1 DL	39. 3 R*
10. 5 U	20. 3 U	30. 5 U	

* partway only

There are several variations to this solution, all requiring 39 moves. The larva can end up at either the top or the bottom.



203-F. Butterfly. I must devote a little extra space to my beloved *Butterfly* puzzle. After all, who can possibly resist her good looks? The colorful images were printed on photo paper, covered with laminating film, and glued to ½-inch-thick hardwood blocks. The tray is Brazilian rosewood. From the starting position with the monarch showing, 31 moves are required to bring the swallowtail together. But surprisingly, only nine moves are then required to restore the monarch. Now how can that be?



Butterfly

A sliding block puzzle

From the starting position shown on the other side of this sheet, without lifting the pieces from the tray, rearrange them to put the Swallowtail together. The shortest path requires 31 moves.



Then, from that solution, continue rearranging the pieces until the Monarch emerges again. The shortest path this time is only 9 moves. Now how can that be possible?



And with that we close the book on sliding block puzzles.

204. Shape Shift. Five multi-colored solid polyominoes come assembled in a 4x6 tray, and the problem is to rearrange them so that no two like colors are next to each other, and also with color symmetry. A second 4x6 arrangement exists and also a unique 3x8 arrangement, but neither satisfies the requirements of symmetry. The solution is to pack them in the unique 2x3x4 solid arrangement. There are two different versions of this puzzle: three-color and four-color. Tom Lensch has made a nicely crafted four-color version that he calls *Shape Shift*. So far as I know, the three-color version exists only as a sketch still stored in my files and shown on the right below in the starting position.

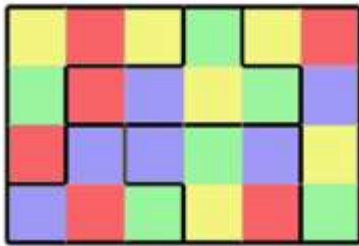

STARTING ARRANGEMENT OF 4 COLOR VERSION

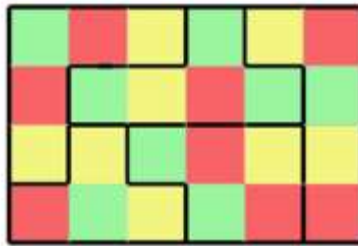

STARTING ARRANGEMENT OF 3 COLOR VERSION

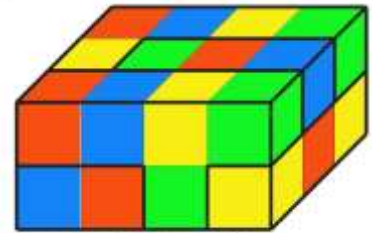

SOLUTION TO 4-COLOR

205. Cube-16. It represents a conversion of *Patio Block* #82 from an eight-piece box-packing problem to a five piece interlocking cube. This version is beautifully crafted in zebra wood by Wayne Daniel for an IPP exchange.

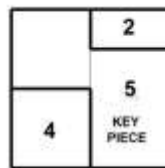

TOP LAYER

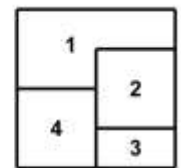
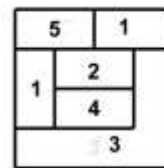
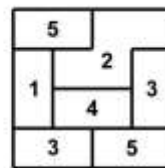

BOTTOM LAYER

206. Polly-Hedral. This is an improved version of *Chicago #191* using six colorful contrasting woods. It was used in the IPP puzzle exchange in 2006.



207. The Park. It was designed especially for the IPP in Boston in 2006. The first three pieces assemble by fascinating but not difficult coordinate motion; the last three are serially interlocking. I provide a big hint by marking the pieces in order of assembly F-E-N-W-A-Y, hence the name. One of my more satisfactory designs in this category.

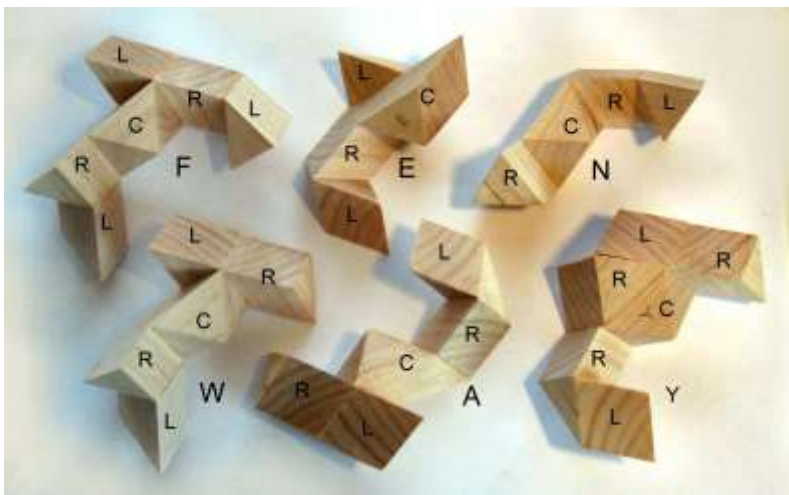
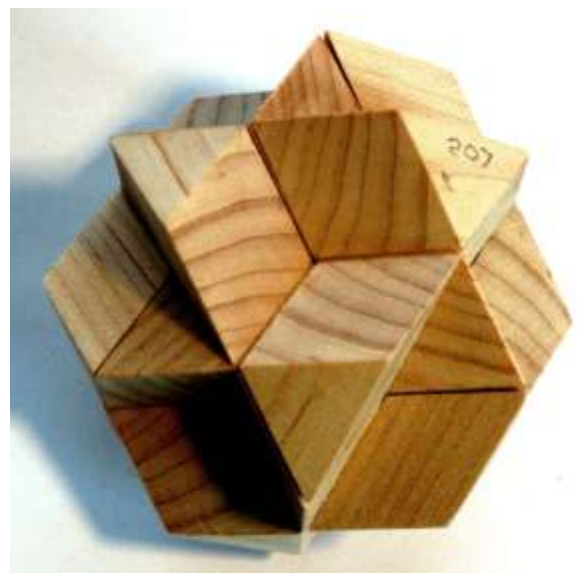

207-A. The Hill. This one was likewise designed for the Boston IPP. The six interlocking pieces are marked B-U-N-K-E-R in order of assembly. This one is more difficult, with the first step of assembly being tricky and unusual four-piece coordinate motion.

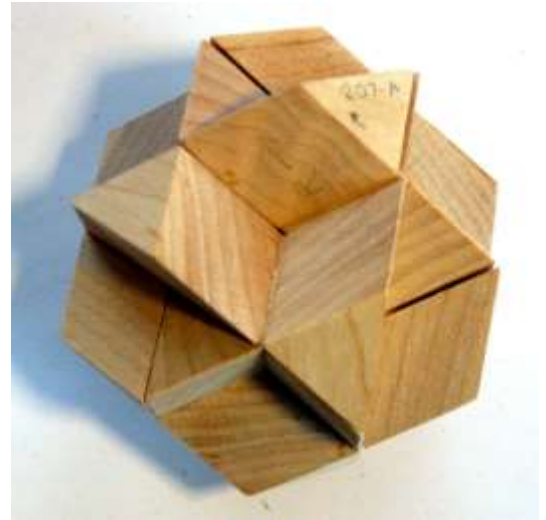
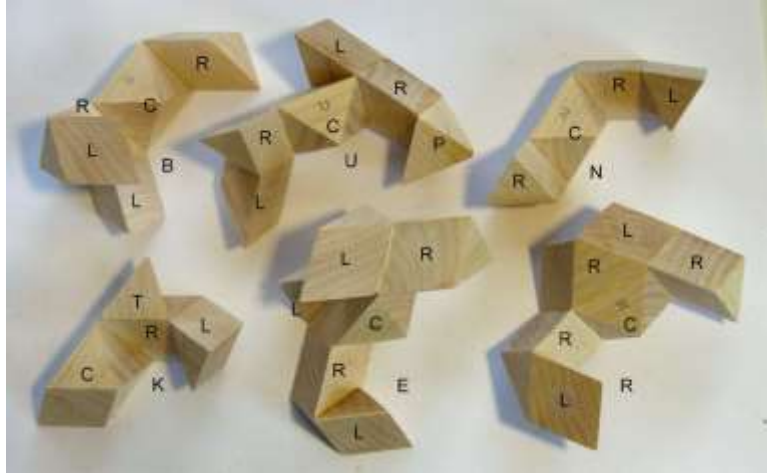

208. Tripp's Puzzle. Six polycube pieces pack into a 2x3x4 box eight ways. They will also make a 2x2x6 solid. It was originally made in six colorful woods for Mary's three-year-old grandchild. (Later it was revised into pieces glued up from multi-colored cubic blocks, to be packed into the box with color symmetry, see below.) I analyzed several versions and may have made one or two models of each. One example is shown here. For shape of pieces, see #208-A.



208-A. Tripp's Puzzle. This is a four-color variation of the above, to be assembled such that no like colors are next to each other. There is only one solution, and the pieces are shown oriented accordingly. One made in 2006, but its destiny is unknown (not that it matters), so this graphic will do instead.

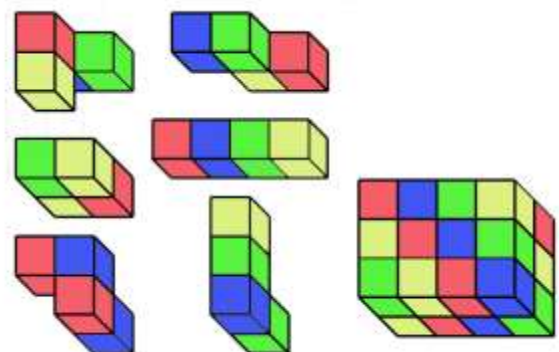

208-B. PuzzleSolver. Here we have yet another variation of Tripp's Puzzle, but this time made with light and dark cubic blocks joined together, to be assembled with color symmetry. The name comes from a nifty puzzle-solving program that I find very useful in the design process.



Puzzle 208-B

1. Assemble the six pieces inside the box; not difficult; there are eight ways.
2. Assemble such that a symmetrical color pattern appears, both top and bottom. There is only one way.
3. Do this such that the wood grain direction is also symmetrical.

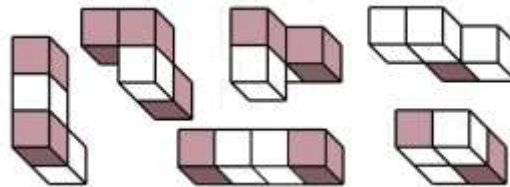

STC, Feb. 2006

209. EL-Gate. Six polycube pieces are to be assembled inside a 2x3x4 box with acrylic top through an L-shaped opening in one end (shaded). The pieces are numbered in order of assembly and shown in their final orientation. There may be more than one solution. Rotation is obviously required.

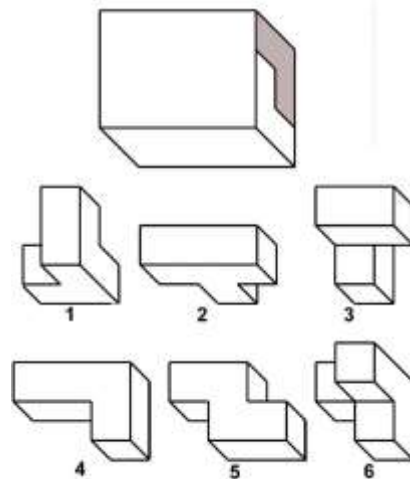

210. EL-Hole. Six polycube pieces, five of one kind **R** and a sixth its mirror image **L**, are to be assembled inside a slightly oversized 2x3x4 box with L-shaped opening in the top (shaded), presumably one way and in one order only. The numbers indicate the order of assembly, which is quite tricky and involves rotation. An IPP exchange.

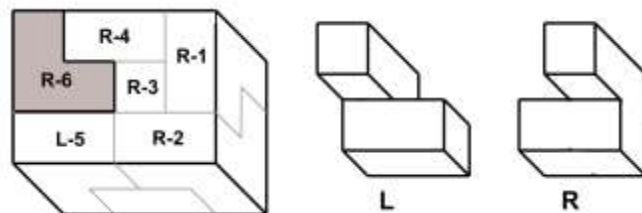

There is an alternate version, 210-X, that instead uses three of each kind of piece but is otherwise the same.

211-2. Block Lock. You might think that something as mundane as dissection of the 3x3x3 cube would have been pretty thoroughly explored by this time, but I wonder. Over the years I have occasionally returned to the baffling challenge of discovering a five-piece 3x3x3 serially interlocking cube with all dissimilar non-symmetrical pieces. This is about as close as I have come. The puzzle is serially interlocking, and the only flaw is that the locking block and one other piece are symmetrical. The world of puzzledom awaits some clever inventor to improve upon this design or, for still more exercise, prove that the sought for perfect design does not exist. Like the *Solid Block Puzzle #78-C*, *Block Lock* is easily made using one-inch hobby store maple cubes. Again the grains should all run in the same direction for stability. Of course, knowing that is an aid to solving.

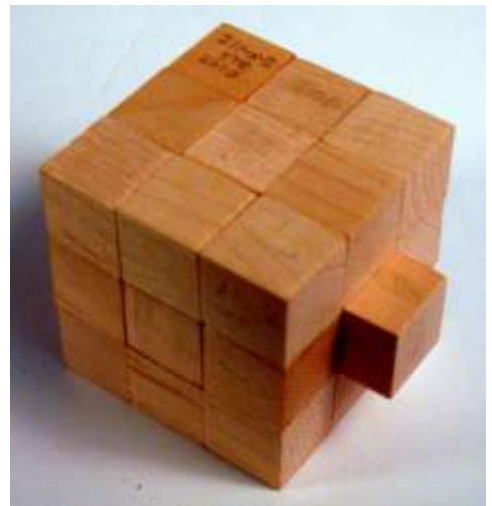

211-4. It's a Knockout. This novel five-piece dissection of the 3x3x3 cube was used as an IPP exchange puzzle in 2006. It has two key pieces, one of which is a single cube and the other is two joined cubes. One fits loosely and the other more tightly. One must be extracted to unlock the puzzle. The two key pieces can be assembled either one of two ways, and since one is loose and the other tight, there are four possibilities, almost too complicated to explain. In the two simple ways, the loose single or double key is gently knocked out to unlock. In the third more baffling way, the loose double block is knocked out to permit access to the single block, which is then poked out from inside to unlock. In the fourth way, after removal of the single block the double block must be poked out from inside using some tool, so we shouldn't really count that way. (I suppose to make it fair play, the key piece could be identified by a dissimilar wood.)

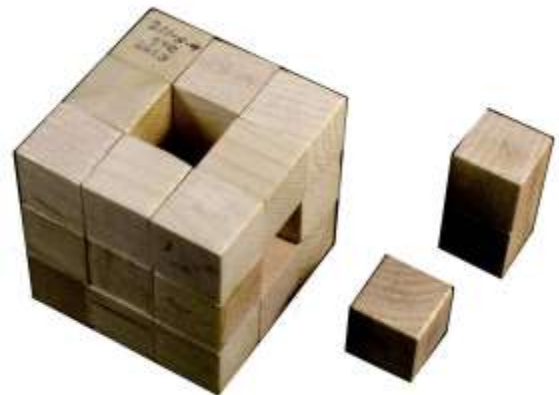

212. Tall Block. This was an experimental interlocking dissection of a 3x3x4 rectangular solid using five contrasting woods – maple, padauk, mahogany, oak, and yellowheart. Only one made.



2	2	4
5	5	5
4	6	5

TOP

5	2	4
5	4	4
4	4	1

1	2	3
1	3	3
1	3	1

1	2	3
2	2	1
1	1	1

BOTTOM

(Afterthought in 2018: Why did I waste my brains designing trivia like this and several others?)

213. (no names) Seven experimental interlocking dissections of a 4x4x3 rectangular solid come under this heading. All were made in contrasting fancy woods with symmetrical patterns on all six faces. I don't know where any of them are now, so once again a drawing must suffice until perhaps one or two turn up. The one chosen for the graphic was designated #213-X-2. (X stands for experimental.) It was made from twelve 1x1x2 blocks and 24 cubic blocks of five contrasting woods. The top part of this probably confusing graphic shows how the blocks are glued together to form the six dissimilar pieces. The bottom part shows the placement of the various woods. The four inside blocks could be any wood.

3	2	5	1
2	2	5	5
3	3	6	6
4	3	3	3

TOP LAYER

3	1	1	1
3	2	2	5
3	1	6	5
4	4	4	5

MIDDLE LAYER

3	1	2	2
1	1	2	5
3	1	4	4
4	1	4	5

BOTTOM LAYER

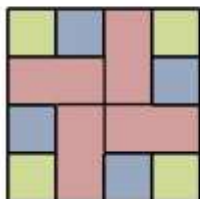

TOP VIEW

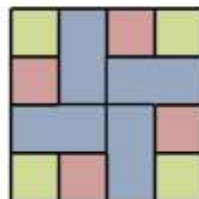

BOTTOM VIEW

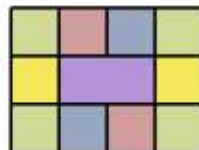

ALL FOUR SIDES



But now this one has turned up because I have remade it. Woods used in this one are yellowheart, mahoe, tulipwood, and maple. Assemble in order numbered; piece 6 is key.

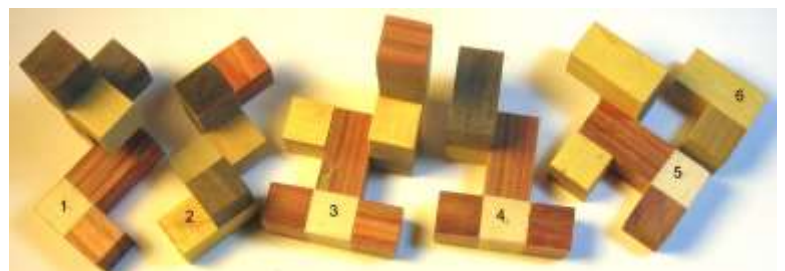

214. Involute. I recorded about a half-dozen experimental modifications of *Involution* #198 including this one. It uses eight pieces rather than seven. One step of assembly involves coordinate motion of a most baffling kind – both rotational and linear simultaneously. The use of colorful woods symmetrically arranged aids in the assembly of this otherwise difficult puzzle, and I also provide directions. Alas, it has a major design flaw, as two pieces are symmetrical. So this can hardly be considered an improvement over the two previous versions. An IPP exchange.

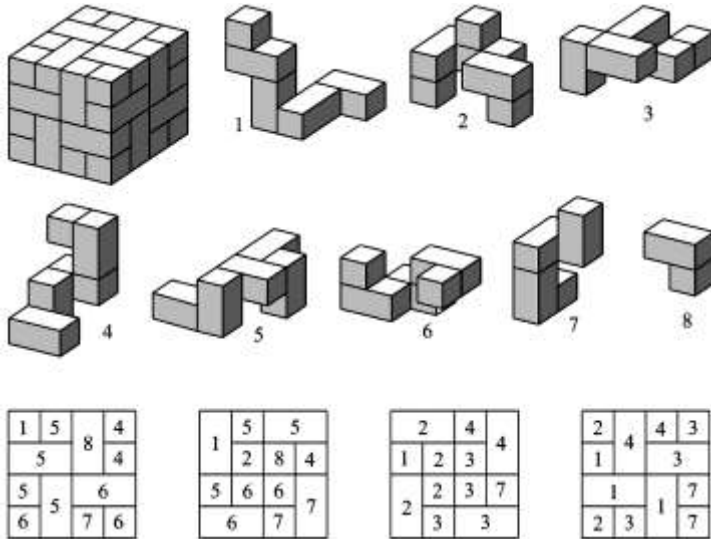

215. Square Dance. Six polycube pieces are packed one way and in one order only into a 3x3x3 box through a 2x2 opening in the acrylic cover. Pieces are arranged in order of assembly, left to right, top to bottom. Some rotation is required. Two pieces are identical. I am not sure if the box can be a tight fit or if some slight looseness might be required for the rotations, in which case the world of puzzledom awaits someone to discover an improved version with all dissimilar pieces and all proper moves.



217. Martin's Menace or Four Fit. For a while I became absorbed in the form of mathematical amusements that I call square root type puzzles. In 2001 I disseminated a 20-page report, *Square Root Type Packing Problems*, with limited distribution. A condensed version was included in the 2014 Appendix. I also wrote a couple articles on the subject and contributed to a third. Out of all that came a deluge of puzzle designs. Rather than clutter up this *Compendium* with all of them, I have selected just a few of the more unusual. I consider *Martin's Menace* the best of all my numerous designs in this category, especially because of its deceptive simplicity. It was an IPP exchange puzzle under the original name *Four Fit*. It is all based on psychology. None of the four pieces rests comfortably in a corner or even touches two sides, so where does one start? Many puzzle experts have been baffled by it, even the great Martin Gardner, hence the change of name. To quote from one of his three furtive letters concerning it: "It's the finest dissection puzzle of all time. It looks easy but is fiendishly difficult. I wasted a week trying vainly to solve it."



222. Out-Back. This was an exchange puzzle in IPP27. The first photo shows the small rectangular block (red padauk) wishing that the four other pieces (poplar) would move over and make space for it. The frame is red oak. The enhanced second photo is of course the solution. Again, note the difficulty in solving, for none of the four pieces rests comfortably in a corner or even on an edge.

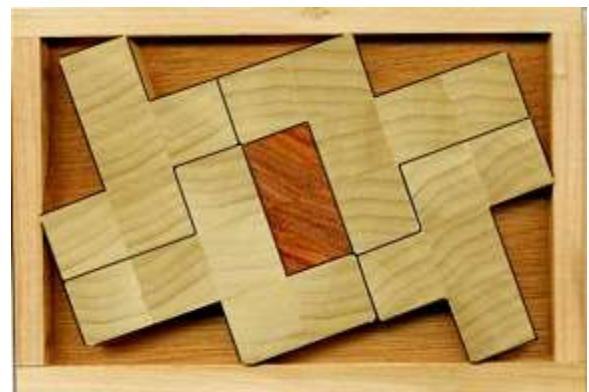

223. Checking In. This eight-piece dissection puzzle is based on the tessellation of the plane into isosceles right triangles. It exploits our natural tendency to fit square corners into square corners, as we have been doing all our lives. I intended it to have only one solution, but when Nick Baxter reported finding three using a Bill Cutler program, I revised the design to use two dissimilar woods to be assembled checkered, thus eliminating all but the one intended solution as well as the one

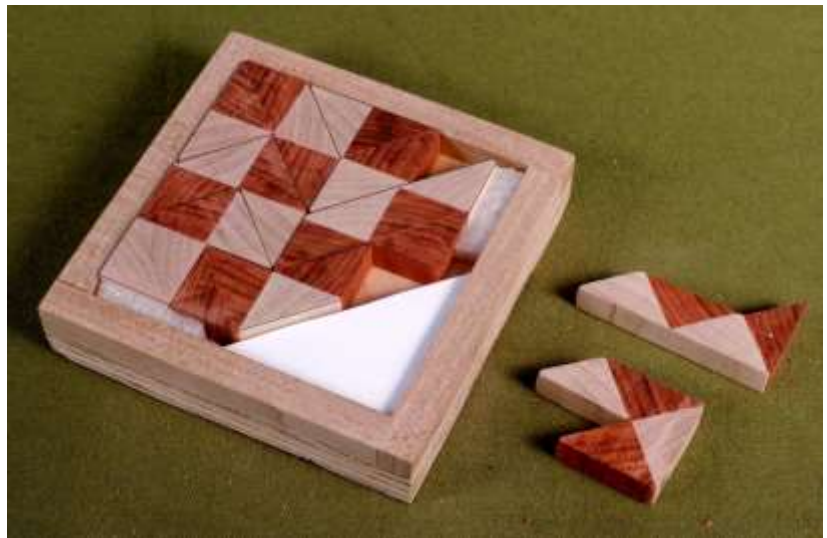

objectionable symmetrical piece. In keeping with my usual practice of providing helpful hints, it comes with six pieces already assembled checkered, held in place with plastic foam packing shims. Now simply find space for the two outsiders. An IPP exchange.

And here is the unique checkered solution.

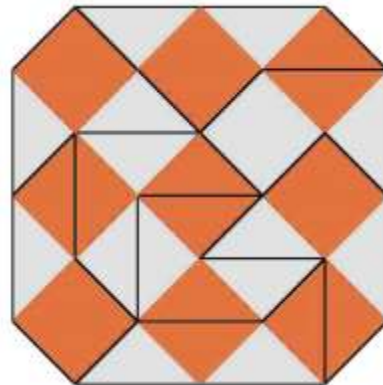

225. The Outcast. The six polyominoes don't seem to quite fit into the rhomboid tray, with the **F** piece being forced to poke its head out through an opening in the top of the tray. Problem: Make room for all inside. An easy puzzle for woodworkers to duplicate, but perhaps not so easy for friends to solve. (There ought to be an improved design with fewer symmetrical pieces, but is it really worth the effort?)



227. Basket Case. The five polyomino-type pieces in a trapezoidal tray are believed to have only one solution. An IPP exchange.

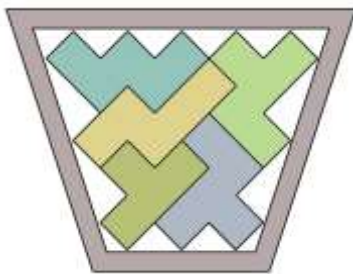

The challenge in designing combinatorial puzzles with empty spaces is that as the empty area increases, so does the likelihood of multiple unintended solutions, especially jumbled up ones that I call incongruous solutions. The only way I know to look for them is by tedious trial and error, and even then one is not sure. Several of the skipped serial numbers here are of designs that proved to have unwanted solutions. (See comments on page 193.)

228. Union Square. (Originally *Computer Killer #2.*)

Designed specially for the 2009 IPP exchange, the idea being that the layout of the solution does not quite conform to a regular square grid, therefore making it impractical to solve by computer. Note small gap in center. This model was expertly crafted by Tom Lensch. The six pieces fit so accurately that I have outlined them with black lines. It needs to be made this accurately, with close fit, or there will be unwanted solutions.



231. Half & Half. It comes with six checkered pieces made of light and dark cubic blocks joined together different ways. When arranged as shown, a light and dark block are clearly out of place, and the pieces need to be rearranged, still in a solid rectangle, to be all dark on one half and light on the other half. Fairly easy to solve, once you discover the trick. An IPP exchange in 2010, possibly under a different name.

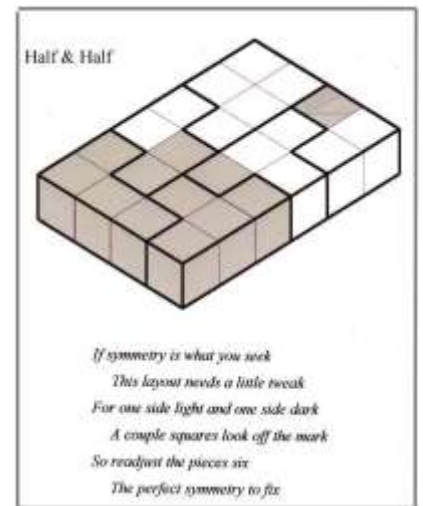

231-A. Half & Half. Sometimes it's the little things that can make a difference. As so often the case while preparing this *Compendium*, I had no model to photograph so had to make another one. In doing so for this puzzle, I came up with this novel tray with light and dark plywood base. An improvement? I thought so, but in any case it was fun figuring out how to make.



232. Ball Octahedron. This represents my attempt to design an interlocking puzzle using spheres joined together different ways. It is serially interlocking, but just barely so, and then only if the balls are joined together accurately and strongly. It was made by Wayne Daniel as an IPP exchange puzzle. Smaller photo is of my intended prototype with interlocking oak and plywood base.

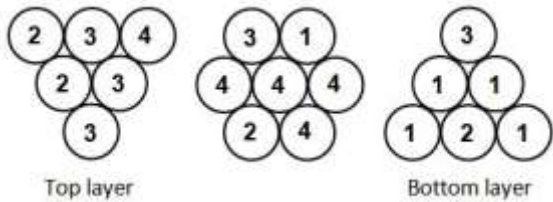

237. The Rattle. Seven solid polyominoes get stuffed into a 4x4x2 box with acrylic cover through a 1x2 slot on one side. Not quite your usual packing problem because an eighth piece remains forever loose inside, hence the name. This model is by Henry Strout, who used it as an IPP exchange puzzle.

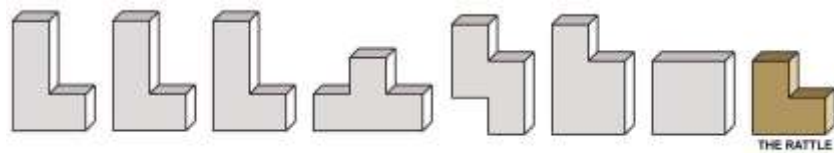

238. Quadrille. Several puzzles already described have used drilled hexagonal sticks held together with pins. When my large supply of hex stock was finally used up, I switched to using round dowel stock instead. This one is in oak. *Quadrille* is made up of eight identical rods and eight pins. Each rod has four holes. Some of the rods and pins are joined to form one elbow piece L and three T pieces. Several other variations are possible. It has a four-fold axis of symmetry (see also 81-C-1).



1. Join T-2 and D-1, and pin them together with T-1.
2. Place D-2 in position as shown.
3. The second T-2 pins D-1 and D-2 together, while it is pinned by T-1.
4. D-3 and D-4 are placed on protruding pins.
5. The pin of elbow L is inserted into T-2, D-3, and T-1, and L is then rotated into position.
6. The four pins are inserted to complete the assembly.

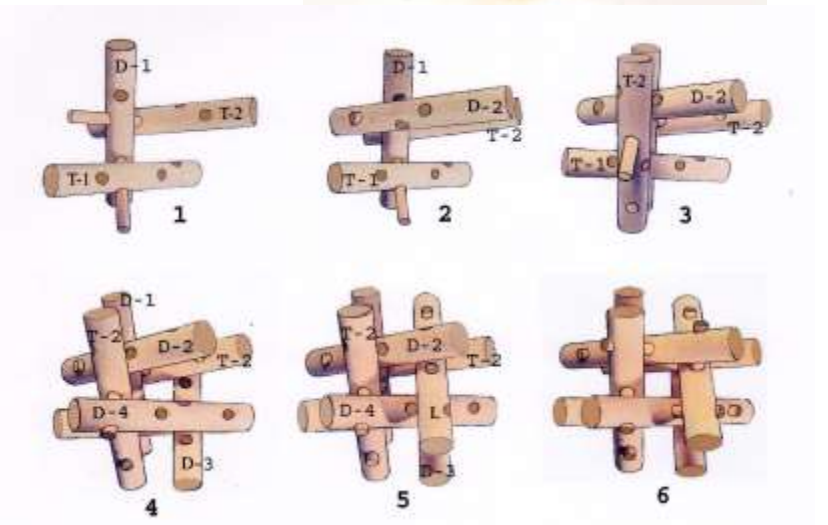

239. X-ercise. The original version of this puzzle used five cross pieces, three elbow pieces, four bars, and four pins. The scheme was to maximize the number of cross pieces, hence the name. It was supposed to have only one solution, but some friends reported finding more. I suspected this was possible only with some looseness of fit or use of force. Be that as it may, it is superseded by the revised version #239-A, next page.

Instructions for Design #239: Assemble as shown.

Designing puzzles of this sort is simple. One starts with the 12 dowels and pins assembled but not joined together and judiciously removes them bit by bit. Nothing to it. To make it into more of a creative process, I tried to minimize the number locking pins (4) and maximize the number of crosses (5). I have found only one solution but there may be others.

STC, March 2010



239-A. Eight Elbows. When the above was found to have multiple solutions if slightly loose, I revised it to have eight elbow pieces and only one solution with minor variations. I made a half-dozen of these for friends, and offered a prize for anyone who would send me a “proper” solution with nine elbows. I received two nine-elbow “solutions” that were possible only with looseness of fit. I also received a neat proof from Bill Cutler that the sought for nine-elbow solution was impossible, so Bill won the prize.



240. Double Cross. This is one of my more satisfactory designs in this “drill and fill” category. Simple, yet not so simple. In fact, surprisingly baffling. It uses two identical cross pieces, three dissimilar elbow pieces, one plain bar, and one locking pin. One elbow piece is shown being inserted, and the remaining two are shown in order of assembly. An IPP exchange.



241. Too Hard. The original version of this puzzle was an apparently symmetrical assembly of nine drilled bars and nine pins, six of which are joined to make four crosses and two elbows, with a three-fold axis of symmetry (see #62). It was to be presented to the unsuspecting victim assembled but with one bar left out, with two of its four holes (first photo, the two facing the camera) apparently drilled at the wrong angle. The challenge is to fill those two empty holes. When I circulated a couple prototypes for evaluation, only Nick Baxter solved it, and the bizarre solution (second photo) was judged too difficult for use as an IPP exchange puzzle (even though it is the practice to provide these presumed puzzle experts with solutions to the exchange puzzles). So that is where this original version, which I will designate #241, now stands.



Here are the twelve pieces of *Too Hard*, shown in order of assembly, waiting forlornly to be put together.



241-A. Sleeping Viper. The revised version, #241-A, is a straightforward assembly puzzle with three-fold symmetry, with no tricky holes drilled at wrong angles. It found its way by this retrograde route into the IPP33 puzzle exchange. This model is by Andy Manvell. The parts are the same as are shown for #241 except for those two wrong angle holes.



242. Spare Parts. I believe in recycling. *Spare Parts* is essentially a *Double Cross* #240 with extra parts. It was used as an IPP33 exchange puzzle, assembled but with the three extra parts rattling around loose in the box. What on earth was one supposed to do with them? Find another solution of course, using *all* the pieces.

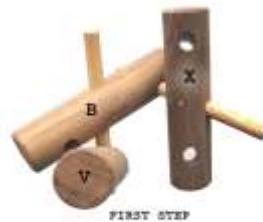

243. Extra Holes. This puzzle arrives looking not quite right, with three empty holes. The challenge – fill all the holes. There are six short bars, each with three holes, and three longer bars, each with five holes. In the side view photo on the left, one of the empty holes is visible. The assembly has three-fold axis of symmetry. The solution is shown on the right, top view along the three-fold axis. Note that this puzzle is made with either $\frac{3}{4}$ -inch hexagonal bars, as on the left in oak, or $\frac{3}{4}$ -inch round dowels, as on the right in walnut. The pins are $\frac{3}{8}$ -inch oak in both.



244. Logs & Sticks. This is an apparently simple assembly of four drilled bars and four pins, similar to Four-Legged Stand #81-B-1, but here slightly distorted from a square to rhombic arrangement when viewed from above. An IPP exchange.



245. Case Closed. Each of the four nearly identical pieces consists of a one-inch oak dowel with a one-inch circular notch bored deep into it at an angle of 68 degrees to its axis. One pair is slightly longer than the other. All four dowels snuggle very compactly together in bizarre coordinate motion that came as a complete surprise to me. I used this version with box (right) in the IPP29 Design Competition. Photo below is of improved version, 245-A, with restrictive box and cover, used in the IPP exchange.



246. Total Eclipse. This version is essentially the same as #245, but in place of the box, when assembled correctly, the four red dots are all concealed. It was used in the IPP30 puzzle exchange. First photo shows the four pieces in place, ready to assemble. Next, right, the four pieces are mutually engaged. Third photo, compressed together. Finally the two pairs of pieces, showing two of the four red dots.

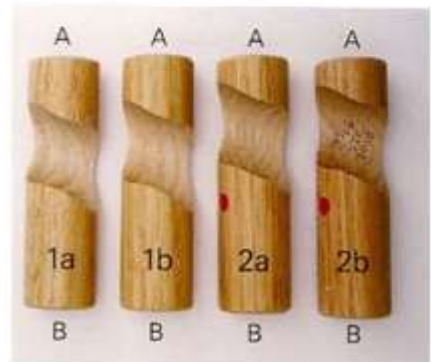

247. Supersymmetry. Six notched $\frac{3}{4}$ -inch walnut dowels are to be assembled to fit snugly inside a plastic jar. The pieces interlock together many different ways, but only one way fits inside the jar. Two kinds of pieces, three of each. Their deep round notches are at 76 and 79 degrees.



250. House Party. Four polyominoes come assembled in a house-shaped tray (left). The problem: Dump them out and assemble them into a slightly different house shape on the opposite side of the tray. The idea being that the opposite side of the tray tends to come up automatically when the pieces are dumped out, perhaps unknowingly, demanding an entirely different approach. This model, well crafted in zebrawood by Tom Lensch, fits with such precision that I have outline the pieces with black lines in the left photo for clarity. On the right is the version used in the IPP exchange, made by Laser Perfect.

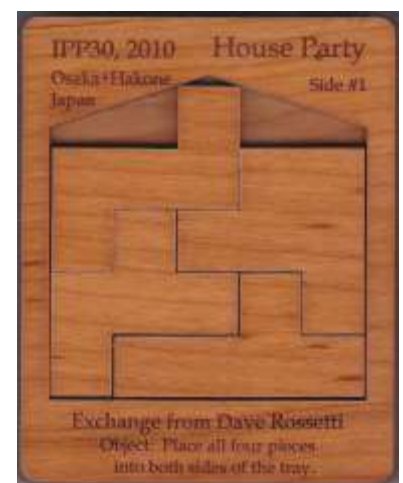

251. Try Angles. This is an unusual sliding piece puzzle in which 12 round discs, all but two of which are joined in pairs, are shifted about within a triangular tray to reposition certain pieces marked in red. Close examination of the photo and graphic should reveal how the pieces are made up. In the graphic, the starting position is in the middle. In each of the three corners are shown possible goals, with many others also being possible. The double pieces are sawn from a pair of $\frac{3}{4}$ -inch oak dowels after being glued together. Perhaps not your favorite kind of puzzle, but oh what fun I had working out the various solutions with fewest moves. One of them is shown below, going from **A** to **B**. An IPP exchange.

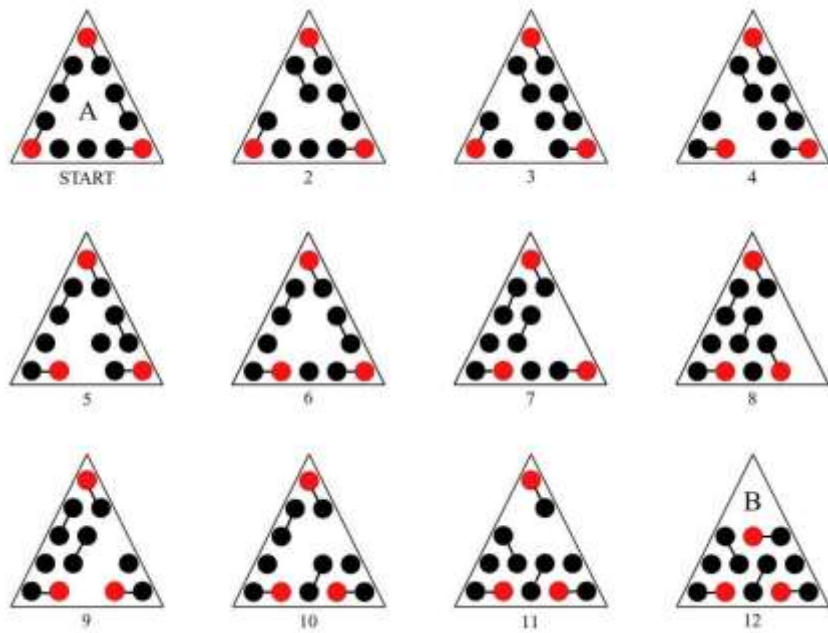
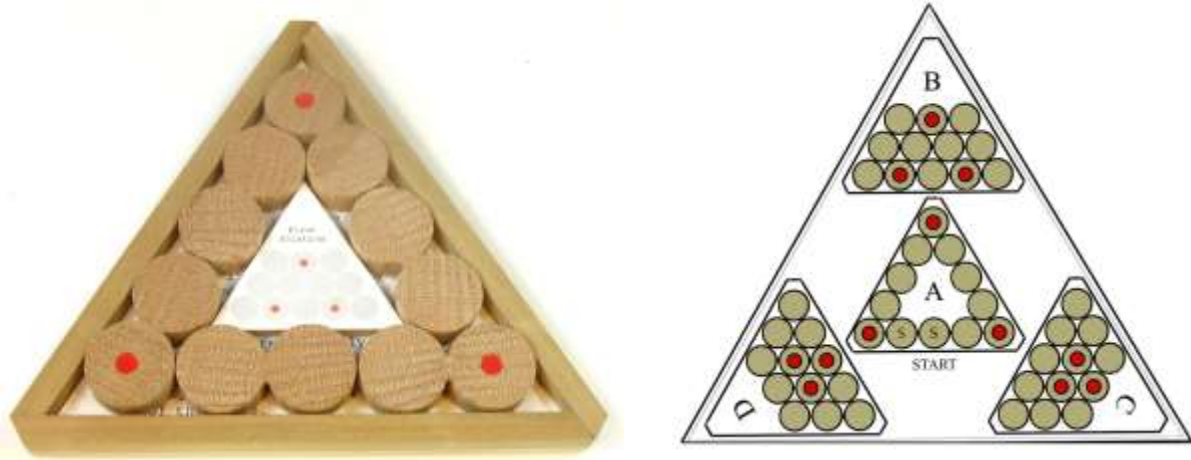

253. Quintet in F. Once again I was asked by a friend to design a puzzle for her use in the IPP puzzle exchange, hence *Quintet in F*. Made with choice poplar and belt-sanded to a fine finish, it was attractive enough. But with five identical pieces, we wondered if it might be too easy. It turned out to be anything but.



255. Lean-2. This puzzle arrives with its four polyominoes cleverly assembled inside a trapezoidal tray (right). The problem then is to dump them out and fit them into a slightly different trapezoidal tray on the other side (second photo). This was an IPP 30 exchange puzzle. Later, Bob Finn, who is very sharp at discovering unintended solutions, not only found one but his will fit into a slightly smaller tray (bottom right). Thus an improved design with that redesigned tray. I do not list it as a separate design because I have never made one and it exists here only as my creation using Photoshop. But I show Bob's solution for the benefit of anyone who might want to make one. Bob's smaller tray not only eliminates an unwanted second solution, but also overcomes the problem that several more unwanted solutions are apt to crop up if the original tray does not fit snugly and accurately.



256. Check Me Out. Four polyominoes fit into a rhomboid tray. (Yes, I know, it's getting repetitious.) When an unexpected and unwanted second solution reared its ugly head, and perhaps yet another with use of force, in desperation I added checkering to the pieces, with instructions to find a solution with two-fold color symmetry (photo), and it was used in the IPP31 exchange.

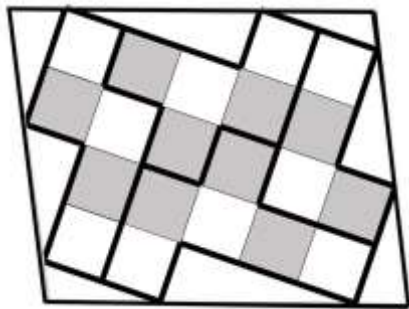

257. Nothing to It. In the category of polyomino pieces in square or rectangular trays, first we had what I call the “graph paper puzzles” with pieces and tray all properly arranged in a square grid, followed by those with pieces vexingly turned to arctan 1, or 45 degrees, followed in turn by others at an even more confusing arctan $\frac{1}{2}$ or 26.6 degrees, and finally the baffling *Christmas 2001* exploiting arctan $\frac{1}{3}$ or 18.4 degrees. Do we see a pattern emerging? Well then, why stop there? *Nothing to It* comes with five checkered tetrominoes (four squares) arranged as shown right, and the first problem, after removing the foam board packing, is to rearrange them into a perfectly checkered 4x5 rectangle, also shown. It's fairly easy, hence the name. Ah, but the second problem is to rearrange them into a perfectly checkered arrangement with outline shape having four-fold symmetry. It has stumped several puzzle fans. If you are game to make one and try it on friends, note that the tray must be oversized just enough to accommodate the tricky solution.

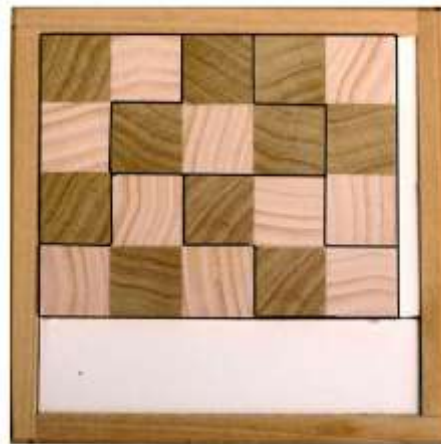

258. Octet in F. It is of course a sequel to *Quintet in F* and it likewise served as my friend's IPP exchange puzzle. Unlike its predecessor, in this one the solution is symmetrical, for whatever little help that might offer. After I had made the entire lot of them, that old bugaboo of a false solution turned up. The many empty spaces add to the recreational potential of the puzzle, but they also add to the challenge of design because they greatly increase the likelihood of unwanted solutions. So I had to modify the tray slightly by retrofitting small spacers. Later I made a few with a redesigned tray to correct that ugly flaw, and that is the revised and much improved version shown in the second photo.

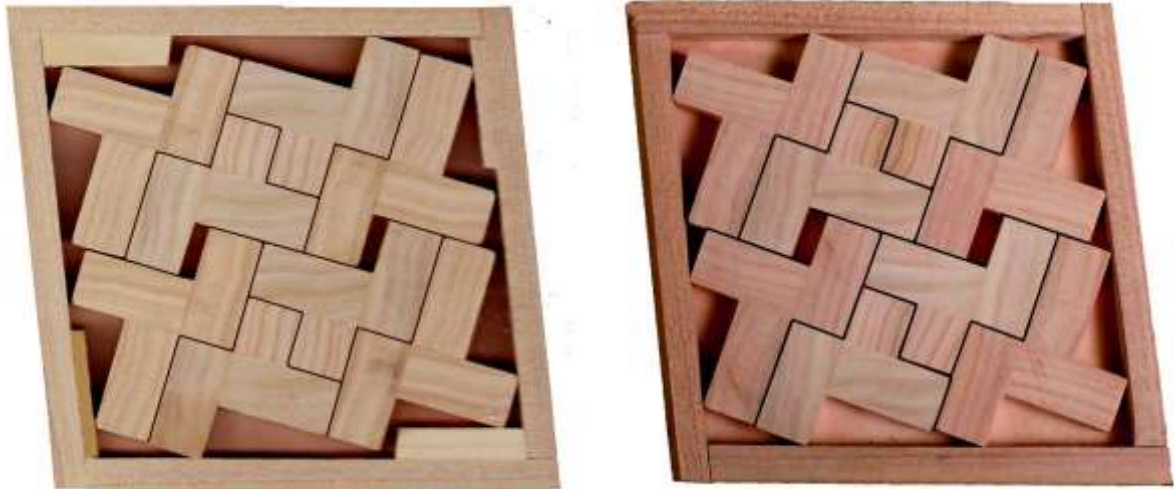

260. Cracked Egg. By definition, a combinatorial puzzle presents the solver with a great many promising looking choices, ideally only one of which leads to the solution. Computers are very good at solving such puzzles with blinding speed, even those with millions of choices. But suppose the number of choices is infinite. Then what? Knowing the ingenuity of some computer programmers, I expect it will not take long for them to figure out how to deal with oval trays, but it does represent a novel departure from the usual polyomino-type puzzle. That's the idea behind this one. The name was intended as a subtle hint at the solution, with a diagonal "crack" all the way across, but few have found it helpful.



261. Threepence. . When I moved to much smaller quarters in Lexington in 2011, for a while I was without much of a workshop, so I sometimes kept myself amused by creating puzzles on the computer screen. *Threepence* is one of several such. A while later I found I could buy pretty good cubic maple blocks for making experimental models. So here are both versions. For its small size and simplicity, *Threepence* ought to nevertheless rank as a satisfactory serially interlocking three-piece puzzle. It could be considered a sequel to *Three-Piece Block* #38. Perhaps it could come with hexagonal container of some sort.

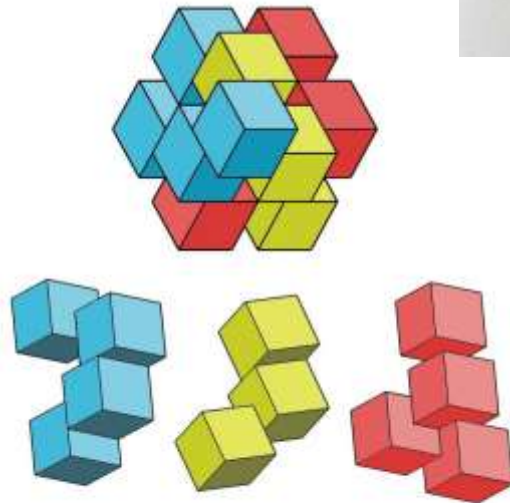

Design 261, STC, February 2012
 Only one solution, serially interlocking
 The one hidden block is red

262. Fourpence. It is sequel to *Threepence*, and could also be viewed as a variation of *Four-Piece Pyramid* #26., likewise serially interlocking. The hidden block is red. Also shown is #262-A, a variation of *Fourpence*. Hidden block is again red.

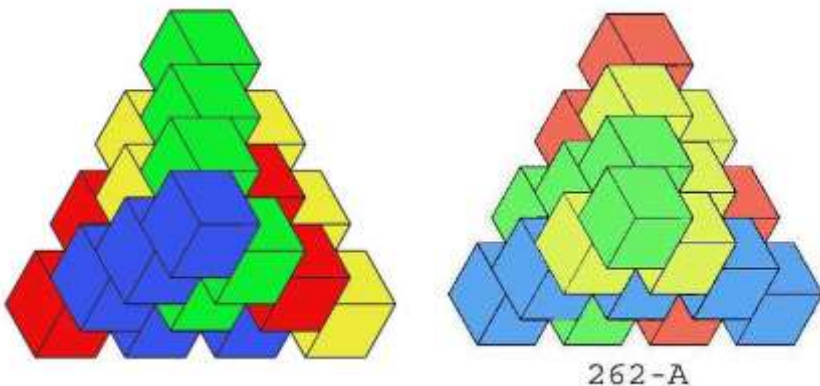
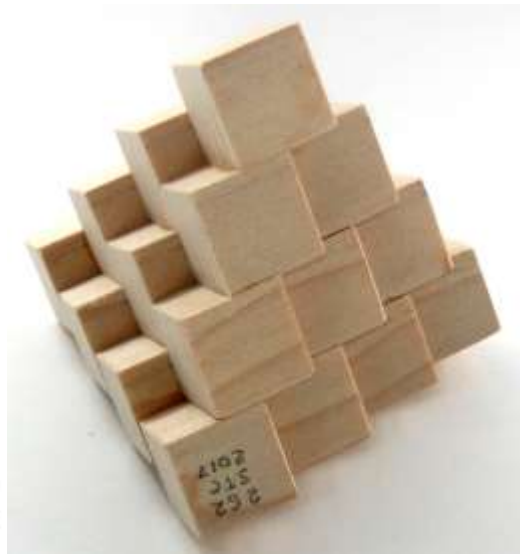

Added note: I have subsequently discovered that in 2001 Don Charnley and Steve Strickland issued their *Q-Cube* Project report, in which they systematically investigate all possible designs of several puzzles of this sort. For this particular one they found 38 serially interlocking 4-piece designs, where I thought I had done well to find just this one by trial and error. Also, in 1999 Roland Zito-Wolf reported finding a most ingenious 5-piece interlocking version, the mere possibility of which came as a complete surprise to me.

263. Unfair Square. Just having fun. No further comment.

*Arrange these pieces
four with care
To form a perfect
checkered square*



264. Clock Wise. It consists of five double disks and one single disk, numbered and arranged counterclockwise as shown inside a six-sided tray. The object is to shift them about to rearrange them clockwise. The minimum possible number of moves is not known, but some of my friends think they have discovered the maximum number!



266. Atlas. It could be considered an improved version of *Locked Nest #22*, using $\frac{3}{4}$ -inch walnut dowels in place of hexagonal birch sticks. The name comes from my supplier of high quality walnut dowels, Atlas Dowel Company. An IPP exchange.

The three pins in steps 1 and 2 are temporary for holding bars in place. They are displaced in step 3 by elbow pieces. Step 4 involves coordinate motion. In step 5, all six pins are inserted to complete the assembly.

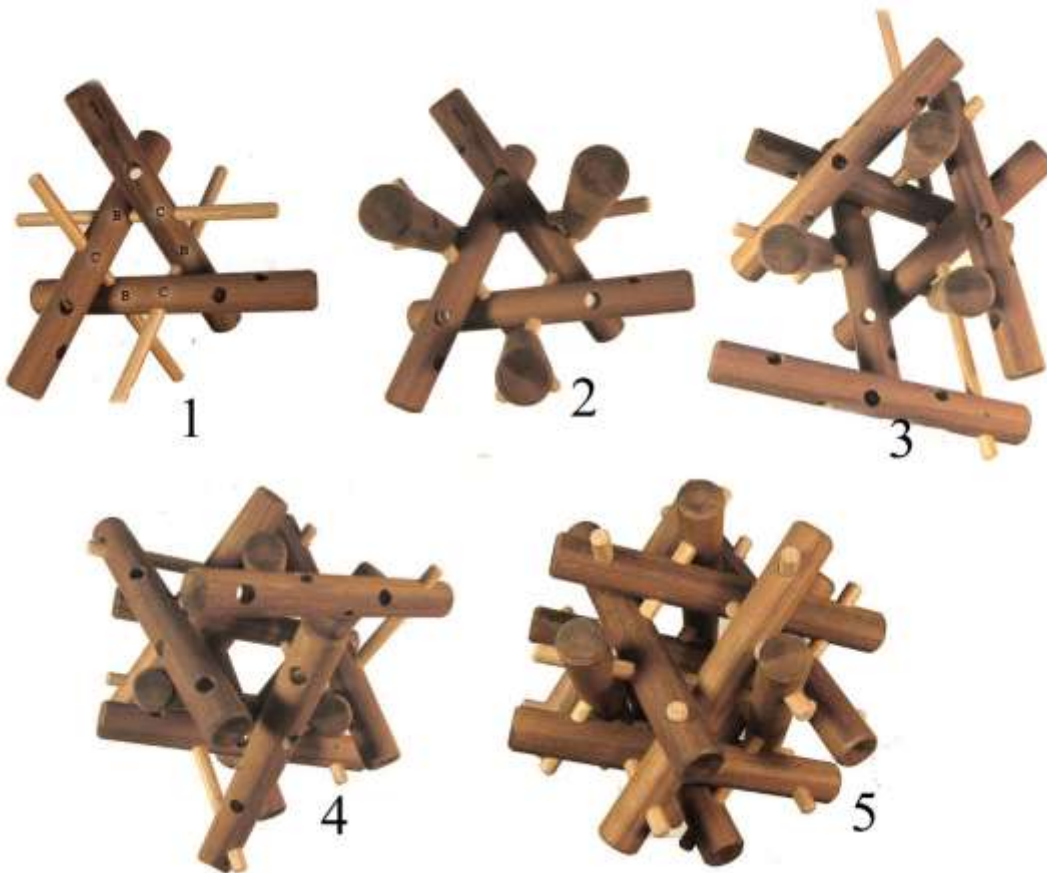

267. Pentastic. Shortly after moving to Lexington in 2011 and presumably retiring from woodworking (for the third or fourth time), I once again got the urge to experiment. So I acquired a drill press and small bandsaw, with which I resumed my passion for drilling holes in dowels and inserting pins to hold them together. Out of this came *Atlas* #266 and several others including this one. The six pieces in walnut and maple are shown laid out in order of assembly. Two pieces are identical. This was an exchange puzzle in IPP33.



267-A. Pentasticks. It is practically the same as *Pentastic* with but a slight change in the lengths of the two short pins (pieces 2 and 5). This was actually the preliminary version, and #267 was the improved design used in the Exchange.



So here we have yet another attractive and seemingly simple symmetrical arrangement of bars held together with pins, but contrived by clever rearrangement of parts to become an enjoyable but not too difficult assembly puzzle. What a strange thing to do, when the rest of the world is in quest of consumer goods made ever easier and faster to use. But even more perplexing to me is that a thriving business enterprise can be sustained by customers willing to pay for such self-imposed difficulty, when the ultimate pleasure comes not from solving such puzzles but the much greater satisfaction of inventing them, and to some extent from figuring out how to make them, plus of course the actual crafting in fine woods. It never ceases to amaze me how lucky I have been in being able to earn a living of sorts doing what I might be doing anyway just as an enjoyable hobby.

268. Sixticks. Figure 91 in my book *Geometric Puzzle Design* is a drawing of a simple variation of the classic *Altekruse* puzzle using only six short pieces rather than the usual twelve, three pieces alike and the other three their mirror image. I must have made at least one experimental model about 40 years ago and found that it had one symmetrical solution, plus a second that I call a “ghost” solution, meaning that the pieces would fit together if only it were possible to assemble.

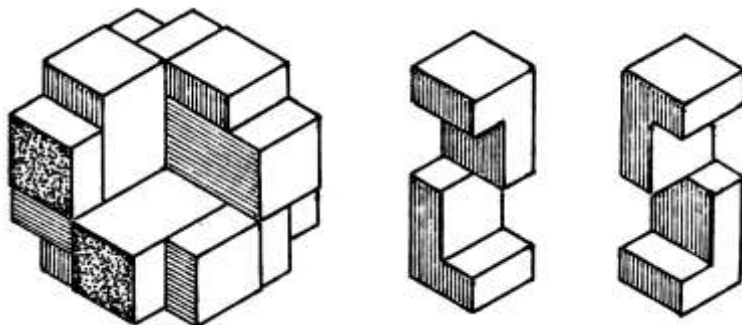

Recently I made another set of pieces to photograph, and of course to tinker with in case something of interest may have been overlooked. This time I discovered several solutions, including some that use five of one kind of piece and one of the other. I then attempted to make a systematic investigation of all solutions but ran into some complications. The pieces join together in a ring of sorts, so one clockwise solution viewed from the top may be the same but counterclockwise viewed from the bottom, or the same sequence but from a different starting point. But there are other complications even harder to explain. So I enlisted the help of two puzzle experts, Nick Baxter and Bill Cutler. They soon did, using their brains and computers, what I was so laboriously trying to do with the actual pieces. In the end we all agreed that this little novelty is not nearly as simple as I had once supposed. So now I call it *Sixticks* and belatedly assign a serial number. Depending on how you count them, it has a total of six actual solutions plus four ghost solutions. Shown here is one of the symmetrical solutions with three so-called left-handed pieces (light) and three right-handed pieces (dark).

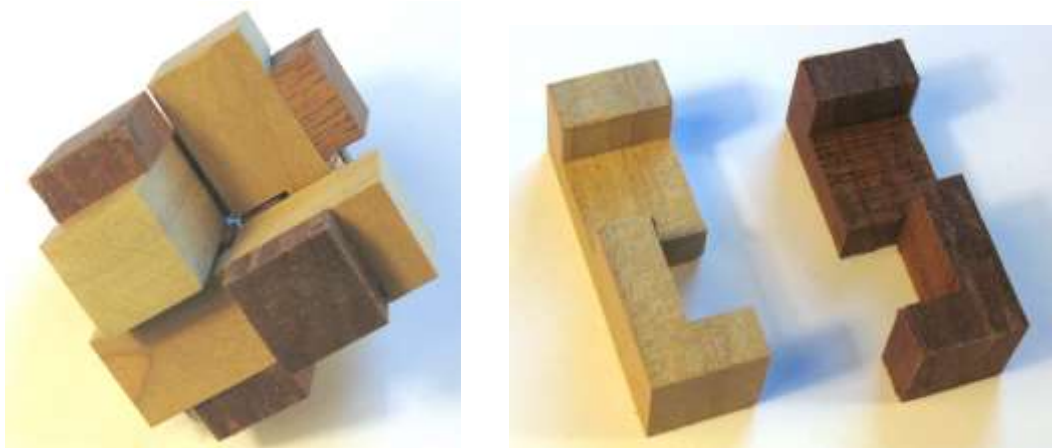

268-A. Rhombticks. Prompted by the *Sixticks* discoveries, I decided to try working with rhombic sticks rather than square, and this is where things got really interesting. There are six possible pieces and they assemble a great many different ways, some more interesting than others. In this drawing, I have exaggerated the angles for clarity. I use 85-95degree rhombic sticks for experimental pieces, although other angles will work just as well.

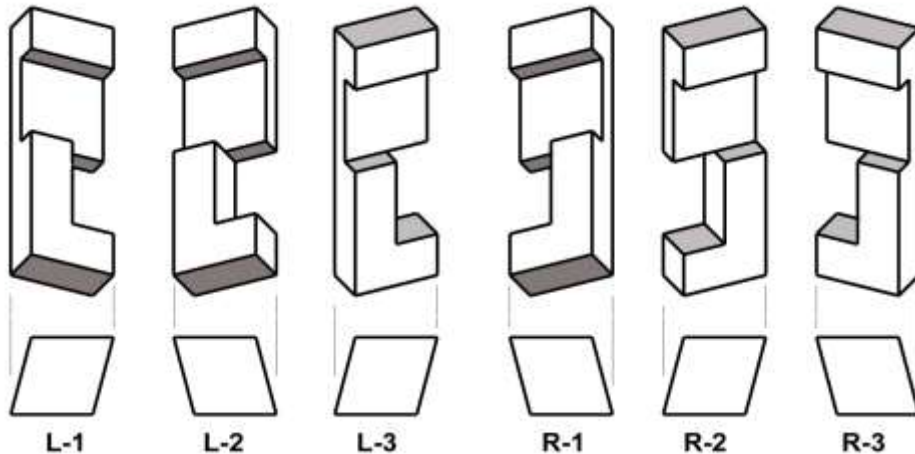

I attempted a complete analysis of all possible combinations but ran into some complications. While doing this, I discovered something that had until recently escaped my attention. In my initial woodworking with *Rhombticks*, I found I had unknowingly been making two kinds of pieces that were mutually incompatible. In setting up the saw jig, there are three angles to consider – the tilt of the saw table, the feed angle relative to the miter grooves, and the tilt of the rhombic sticks forward or backward (as already mentioned in the discussions of design #68). Choosing these randomly can lead to much confusion. After making one set of pieces, reversing any one angle produces a second set of pieces incompatible with the first. But reverse any two of those angles and you are right back where you started.

One set of pieces will produce what I call the *Squat* solution, while the other set will produce the *Upright* solution. Shown below are both forms. These were created using Photoshop, with the distortions exaggerated for purpose of illustration. On the left is the *Squat* version, and on the right is the *Upright*. To simplify things (if that is even possible) I have limited my investigations to only the *Squat* version. This puzzling investigation is still ongoing.



The two photos below show an assembled *Rhombticks*, first as viewed along the three-fold axis of symmetry, and then a side view to show the rhombic shape more clearly. This puzzle was subsequently used in the IPP Exchange and expertly made by Bart Buie.

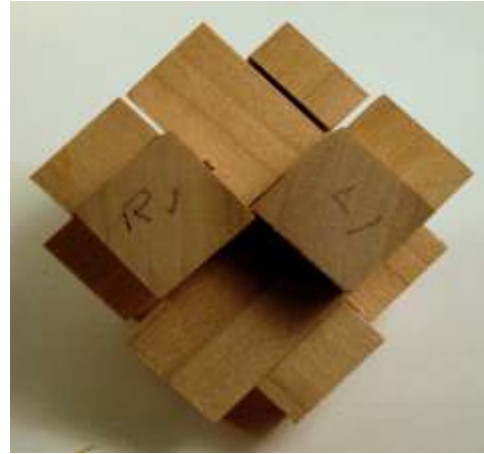
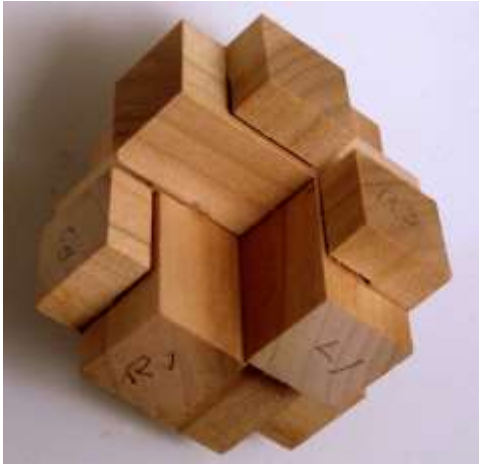

269. Diamonds. It has seven standard pieces, three skinny pieces, one augmented piece consisting of a standard piece with added block, and one key piece that is skinny all the way to one end. It shares with *Concentrix* #100 and *Meteor* #100-A an unusual solution unlike any other known to me, requiring the shifting back and forth of the three skinny pieces before inserting the key piece, rather like a combination lock. The name comes from the 120 identical diamond faces (count them) that adorn the envelope of this intriguing polyhedral design. The basic structure is twelve notched hexagonal rods. Sounds familiar? It is the same as *Hectix*, the sculpture-turned-puzzle that got the whole works started forty-five years ago. Contrarily, I suppose you could consider *Diamonds* a puzzle-turned-sculpture, completing the circle.

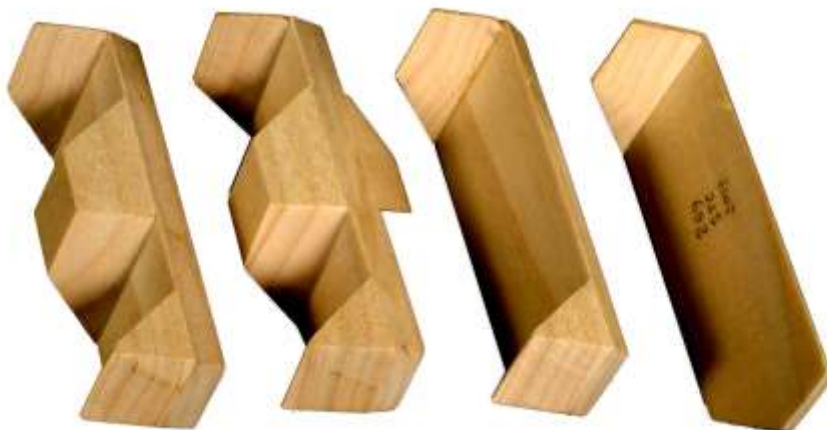
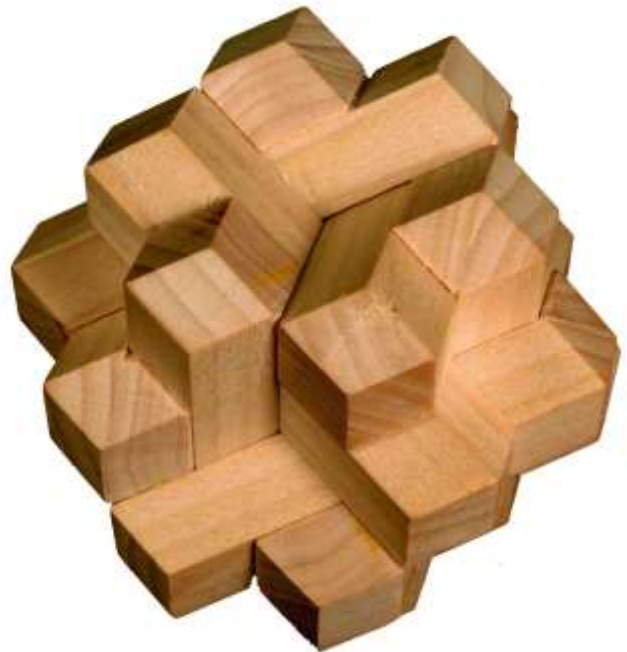

270. Restricted Area. This puzzle has eight dissimilar skewed pieces that pack solid into a box that might be described as a cubic structure tilted askew. All six sides of the box are rhombic. The opening at the top is partially blocked, hence the name. All eight dissimilar pieces are made by joining two identical 2x2x1 rhombic blocks different ways. The box and all pieces are here photographed with the camera aimed *straight down*. There is only one solution and essentially only one order of assembly. This puzzle comes in two forms – squat and upright. For an explanation, see #268-A. Shown here is the squat version. There is a natural tendency to start by trying to fit pieces snugly into the bottom corners, and then working upward from there. If you do follow that method, be prepared for a long session. An alternate approach is to deduce which two blocks must be in the center, and the solution will then follow easily. Used in the IPP exchange.

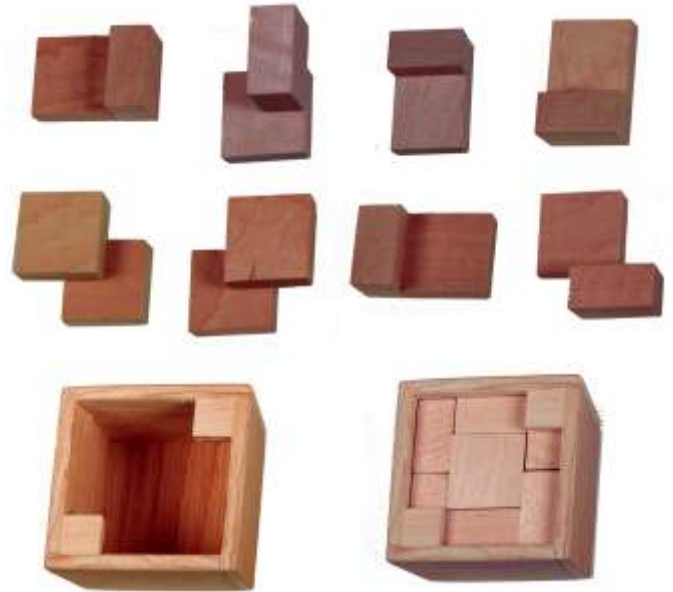

271. Ball Joint. Four dissimilar and non-symmetrical pieces, each made of five spheres joined together, form a triangular pyramid. Note the similarity to *Four-Piece Pyramid* #26. To “facilitate” assembly, a triangular base holds the pieces firmly in place. (My idea of a joke. The tightly fitting base restricts the order and orientation of assembly, turning it into even more of a puzzle.)

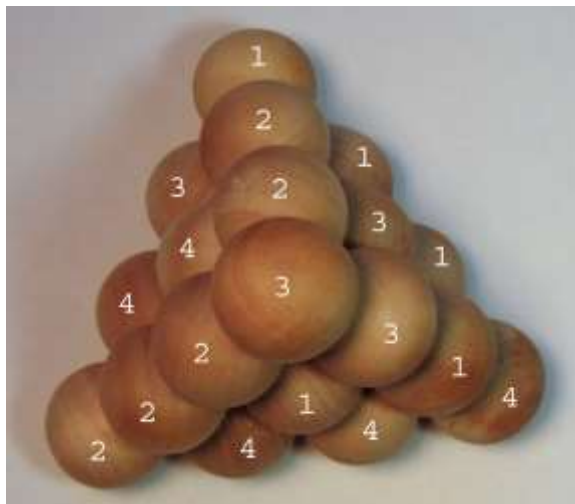
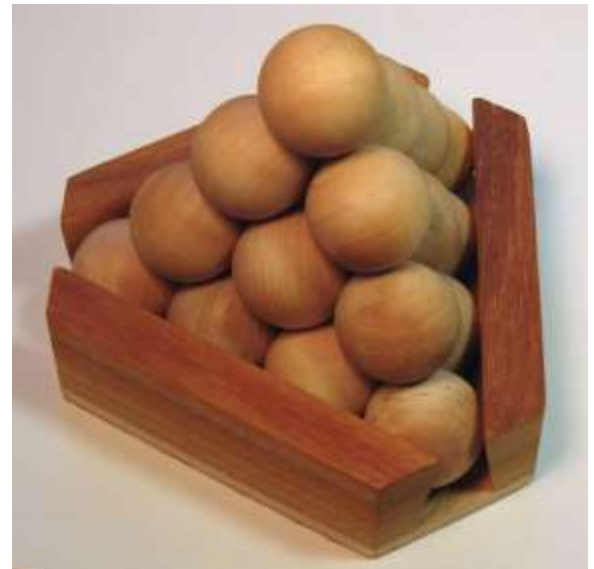

The hidden ball is 3.

The Cube Project. After discovering that Charnley and Strickland had thoroughly investigated many possible puzzle constructions using cubes bonded by half-faces or quarter-faces, I decided to redirect my experiments to novel variations not included in their report. The first two shown are *Fourpence* #262 and an unnamed variation #262-A. We now redirect our interest to the other seven.

272. Anchored Tetrahedron. The hidden center block is attached to a flat triangular base plate (not shown but see below) that serves as an anchor of sorts for the assembled puzzle. The four pieces are serially interlocking.

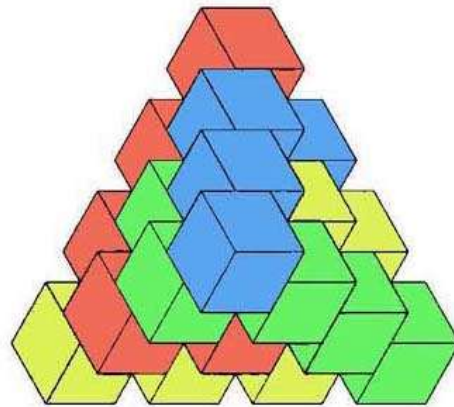

272

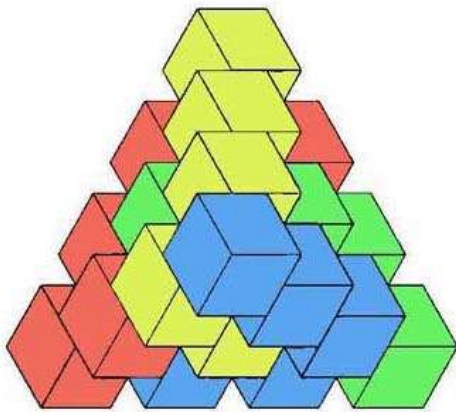

272-A

272-A. Keeping Company. Interlocking puzzles that can be assembled in only one particular order (i.e. serially interlocking) are a popular goal of designers. When this goal is not attained, it can generally be assumed that sequential assembly is still possible but not demanded. Here is an exception – the yellow and green pieces must be assembled as a mated pair. This puzzle is likewise anchored by the hidden center block to a flat base.

273. Seventeen-Block Tree. A somewhat systematic trial-and-error process finally led to discovery of a four-piece interlocking combination (three-piece design is easy) of this little tree with its vertical three-fold axis of symmetry and hexagonal base. The hidden block is green.

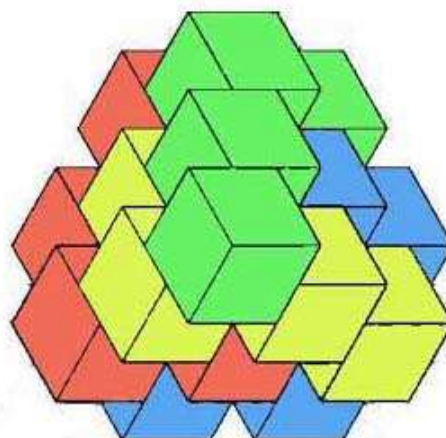

273

274. Christmas Tree. I came up with this serially interlocking design and made a few of these just in time for the 2013 holiday season. It combines the idea of an anchor block and base with the symmetrical shape of the *Seventeen-Block Tree* #273. The tree trunk (short round dowel) connects the hexagonal stand to the center bottom block. I made this one of brightly colored blocks as a gift to a special friend.

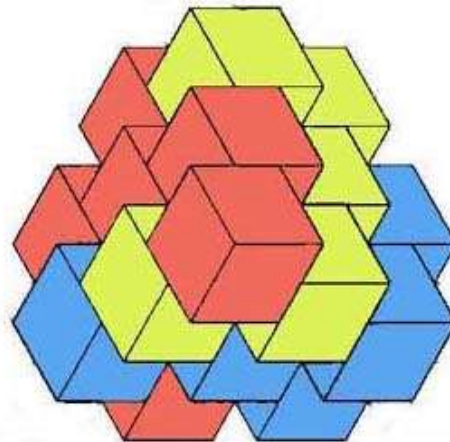

274

274-A. Tricky Tree. This design is a companion to *Christmas Tree* but with one additional complication. The first step of assembly involves a tricky two-axis movement to bring the two pieces together.

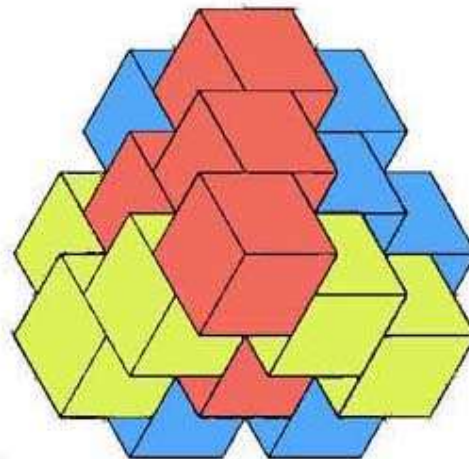

274 - A

275. Truncated Tetrahedron. Evidently this symmetrical 16-block construction was not included in the Charnley/Strickland Q-Cube Project, for which I am thankful. Who knows if their powerful analytic approach might have turned up several serially interlocking four-piece combinations, but I considered myself lucky to have found just this one after a long search. The hidden block is red.

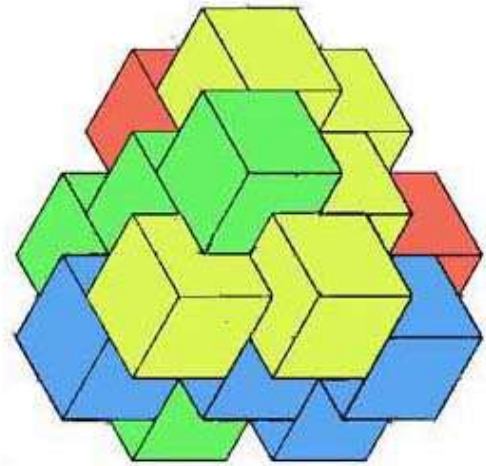

275

275-A. Multi-Grain. This is a companion to *Truncated Tetrahedron* with one significant difference. One of the four puzzle pieces has (dare I say it) an *axis of symmetry*. Throughout this *Compendium* I have mentioned my preference for pieces not having this property. So why not here too? Here it is actually used to advantage. The key that unlocks this serially interlocking puzzle is a symmetrical two-block piece. I normally make the puzzles of this class with the grain of all blocks running in the same direction, which is done to minimize the effects of humidity but can also be an aid in solving. Discovering this key piece and figuring out how to coax it free can be frustrating. For those friends of yours who are perhaps prone to become impatient and use excessive force, which can easily break this puzzle, you have the option of reversing the key piece so that the different direction of grain stands out to identify it, and you can offer that as a hint. It shows clearly in the photo. I didn't start out with that design idea in mind. If only I were that clever. It just happened. This is my favorite of the seven in this category. Hidden block is again red.

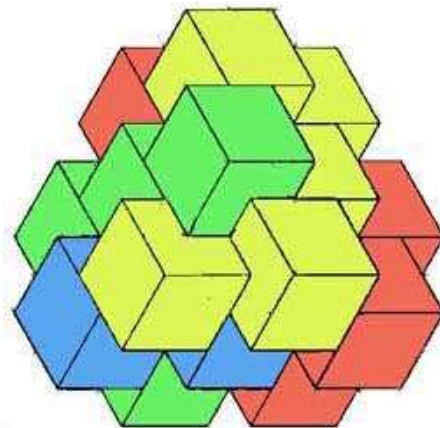

275-A

Part 4. AP-ART Models

As I was contemplating this *Compendium*, I started wondering. Considering all of the mostly new and original puzzle designs that I have listed and described, does the world really need any more bewilderment inflicted upon it at this point? Perhaps the time has come for a slight change of direction. If you have managed to maintain your sanity thus far, you may now relax and enjoy something less taxing. I have decided to start a new serial list of intriguing three-dimensional models that serve a variety of functions, such as demonstrating some geometric property, perhaps to be assembled as a kit, or perhaps just to be displayed and admired. I will call them my AP-ART Models, designated by the letter M.

M-1. Thirty Triangular Sticks. In my description of *Jupiter #7*, I mentioned the possibility of enclosing a rhombic triacontahedron by thirty triangular sticks, and I included a photo of the model that I have finally got around to making, revealing its polyhedral core. What I didn't mention back there was that the model kindly allows itself to be decapitated, revealing its polyhedral core.

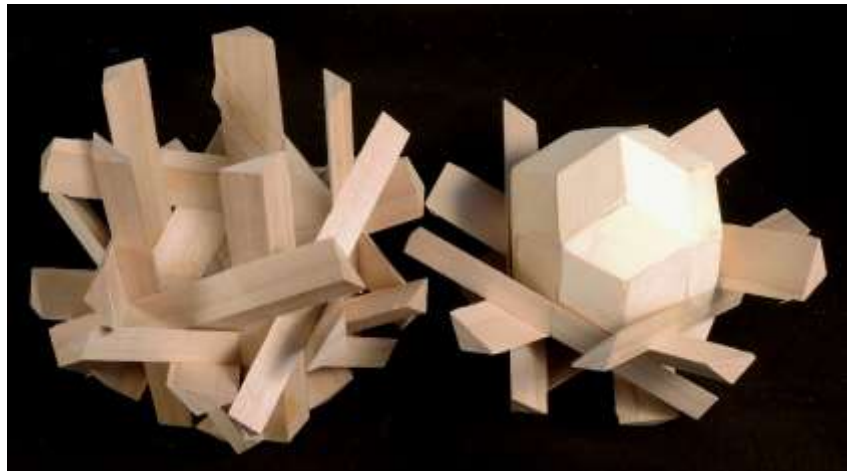

The Pentacage Family. Under this heading are the following four geometrical models: *Three-Hole Pentacage #M-2*, *Five-Hole Pentacage M-3*, *Seven-Hole Pentacage M-4*, and *Nine-Hole Pentacage M-5*. They consist of pentagonal sticks with holes drilled in them through which pins are inserted to create symmetrical interlocking assemblies, following illustrated instructions that presumably would be provided. My 1987 instruction sheet for *Thirty Pinned Pentagonal Sticks #80*, which had seven holes in each pentagonal stick, mentioned that versions with three, five, and nine holes in each stick were also possible. And only now, 25 years later, do I finally get around to actually making the complete set of four, one of each, to be photographed for this *Compendium*.

The three-hole version presents special problems because the ends of the bars interfere with insertion of the pins. In the model shown, this was taken care of by using short pins and shortening one end of five of the bars, thus introducing a slight dissymmetry. There are several solutions, depending on the location of those shortened bars. An alternate scheme is to provide round grooves in one end of some bars. It can be done with as few as three grooves if you know exactly where they go. Thus, a puzzle after all. Can't seem to get away from it.

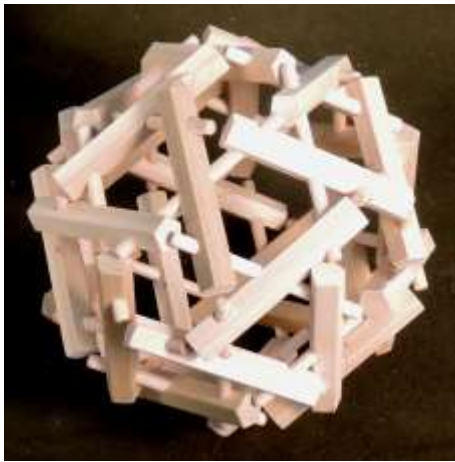

Pentacage M-2

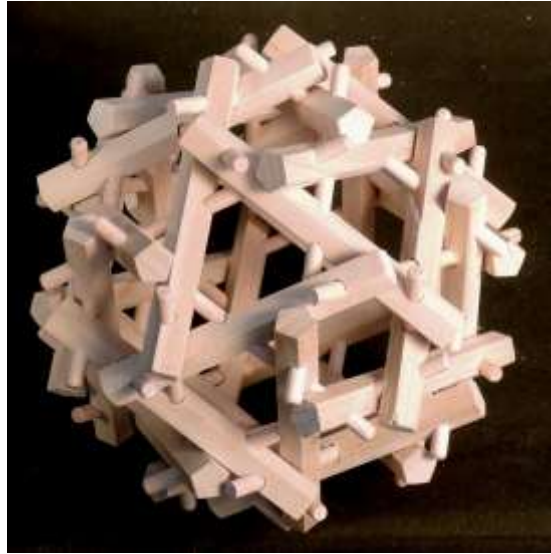

Pentacage M-3



Pentacage M-4



Pentacage M-5

With the *Nine-Hole Pentacage M-5* we have reached the upper limit in terms of size and number of holes. All four of these *Pentacage* models are made to the same scale in terms of stick size and hole spacing. And of course they all have those same 31 axes of symmetry.

The Dowel-Pin Family. These have the exact same geometric structure as the *Pentacage* models, the only difference being the use of round dowels in place of pentagonal sticks. One obvious advantage for the craftsman of these models is that they are much easier to make, since one is spared the necessity of milling out pentagonal stock. Good quality round dowels in three-foot or four-foot lengths are readily available in a variety of fine woods. Another possible advantage is that the intriguing interior of the structure is visually more open to inspection. The use of two contrasting woods adds further to the aesthetic appeal. All four of these models are made with black walnut dowels treated with an oil finish. The contrasting light colored pins are maple or oak.

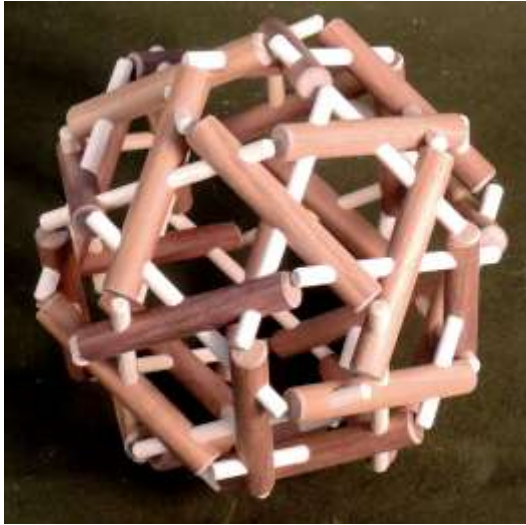

Three-Hole Dowel-Pin M-6

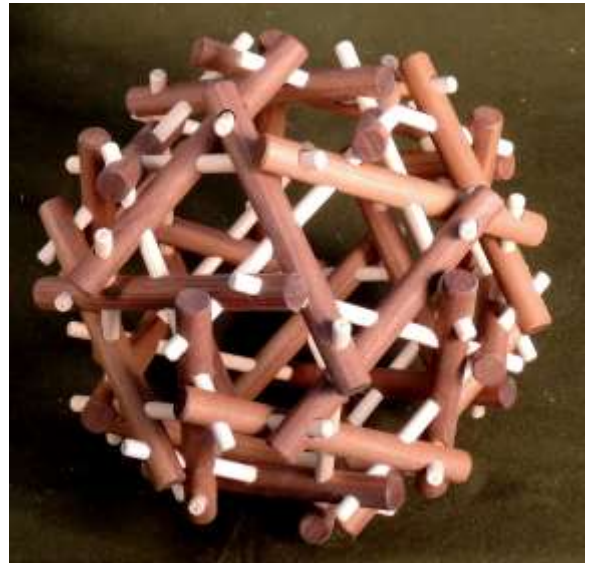

Five-Hole Dowel-Pin M-7

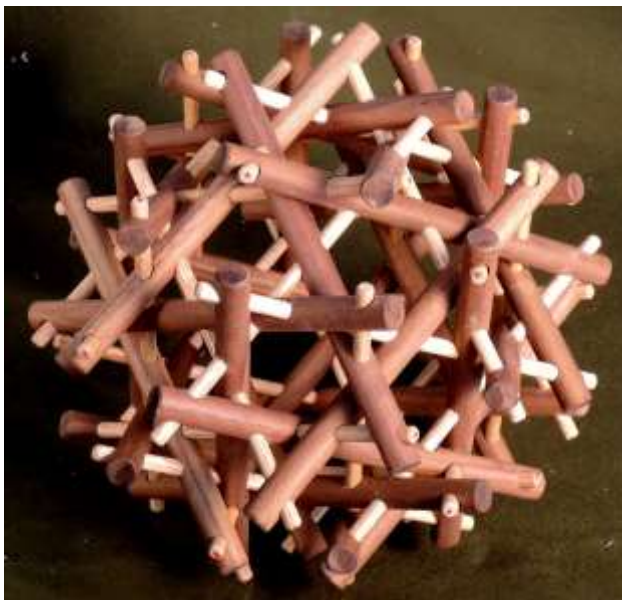

Seven-Hole Dowel-Pin M-8



Nine-Hole Dowel-Pin M-9

How about eleven holes? Alas, nine is the upper limit in our familiar world of three dimensions. But in the imaginary world of hyperspace in four or more dimensions, who knows what may be possible? In our discussion of combinatorial puzzles many pages back, we saw that the ideal design of such puzzles calls for all dissimilar and non-symmetrical pieces, and the fewer the better. But here we have the exact opposite. These models all could be turned into puzzles of varying degrees of complexity simply by joining some of the bars and pins to create elbow pieces. But I have chosen not to. Instead, think of them simply as enjoyable assembly exercises with the reward when finished of intriguing three-dimensional sculptures. And remember? This all started way back in what now seems like ancient history, when that little cluster of twelve notched hexagonal sticks evolved from a sculptural experiment into my first interlocking puzzle: *Hectix*.

Blocks and Pins. Toward the end of my book *Geometric Puzzle Design* is a chapter called *Blocks and Pins*, which is a marked departure from the rest of the book. It consists entirely of my drawings of hypothetical geometric pastimes that existed at that time only on paper and in my imagination, and perhaps also in the imagination of readers. But that will hardly do for this *Compendium*, with its emphasis on woodcraft. So a recent project of mine has been to make at least some of them in my now limited workshop, an undertaking that fortunately does not require much in the way of power tools and complicated jigs. A table saw and drill press are about all that are needed.

M-10. Cuboctahedral Blocks and Pins. This model uses 14 blocks, 12 long pins, and 24 short pins. With more blocks and pins, it can be extended in all directions. A 15th block could have been included in the center, with 14 more pins radiating from it.

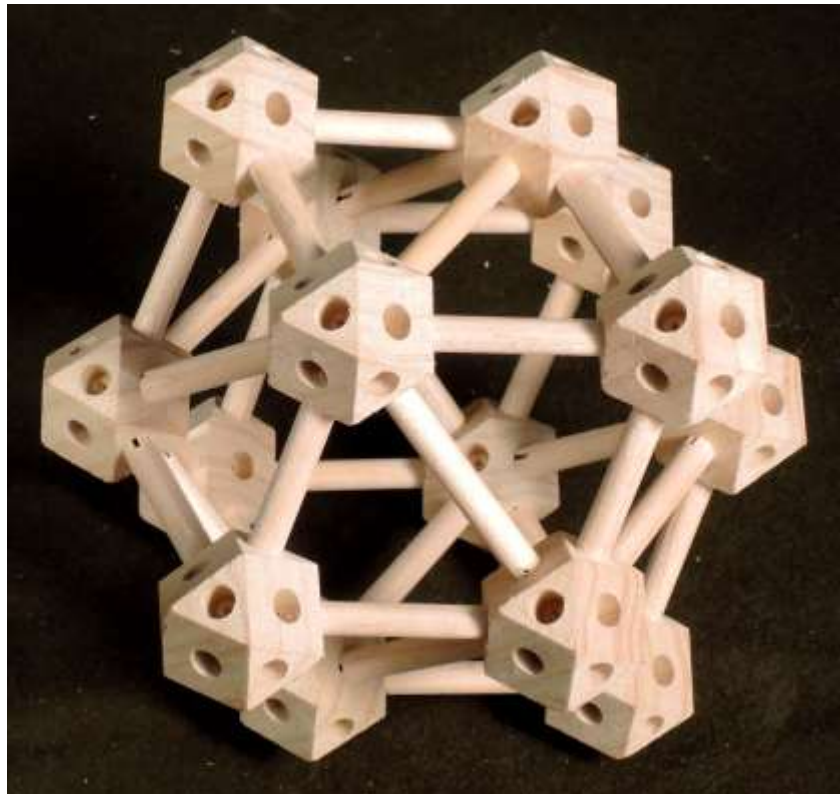

M-11. Edge-Beveled Cubes and Pins. This model uses seven blocks, twelve long pins, and six short pins. Given more parts to play with, it too can be extended in all directions.

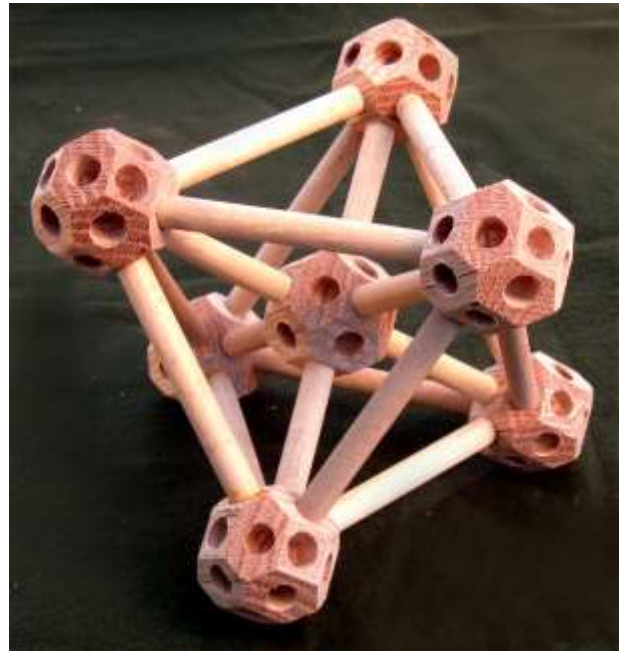

M-12. Dodecahedral Blocks and Pins. Finally, this model uses 14 blocks and 36 pins, and like the others, it too can be extended in all directions. What fun!

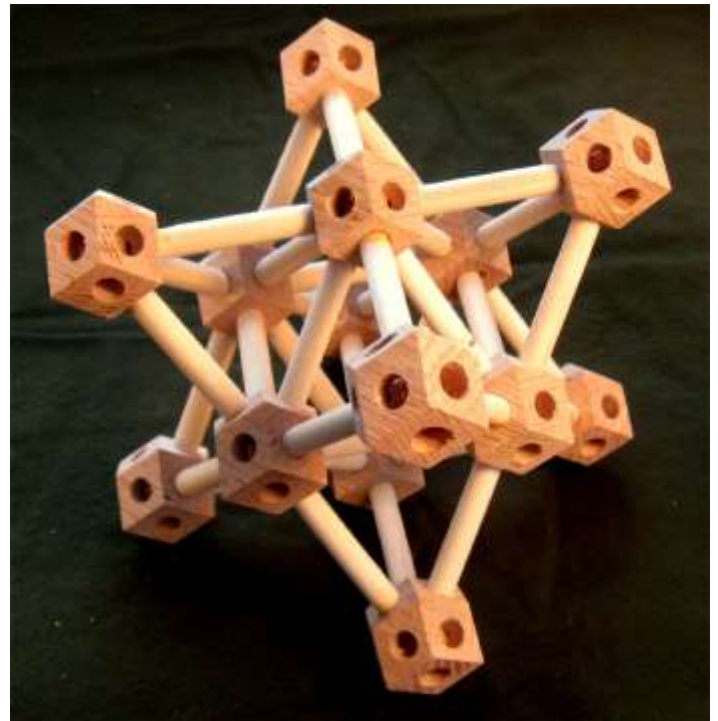

Now here is something that came as a complete surprise to me after I had finished making these models and was admiring them: The cuboctahedral blocks assemble into a shape that is rhombic dodecahedral. The rhombic dodecahedral blocks assemble into a shape that is cubic. And the edge-beveled cubes assemble into a shape that is octahedral, completing the fantastic circle. I find that amazing. No wonder polyhedra have attracted the attention of mathematicians and mystics since the times of ancient Greece.

M-13. Universal Block. Why stop here? Why not a *Universal Block* that combines all three of the above blocks into one super-block? Shown below is such a block with 26 holes, and beside it another block with its 26 holes occupied by pins that define its 13 axes of symmetry. Too complicated? According to Alan Holden in his excellent book on the subject, *Shapes, Space, and Symmetry*, that 26-faced polyhedron is called a *rhombicuboctahedron*. Yes, too complicated in both form and name (!) for AP-ART. I think that in this context, simpler is better.

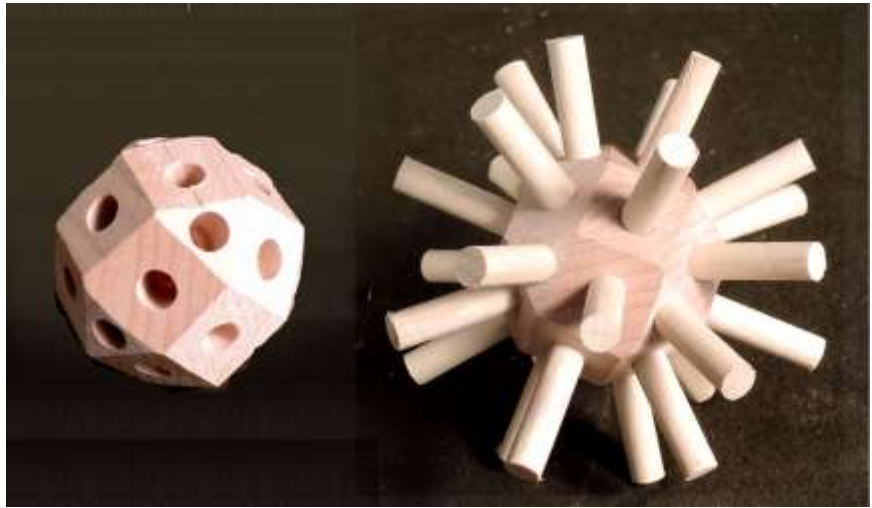

The relative length of pins in *Edge-Beveled Cubes and Pins* is in the ratio of one to the square root of two, the same as in *Tinkertoy*. See if you can tell by inspection the relative lengths of pins in the other two models.

Did we just hear *Tinkertoy* mentioned again? It seems that we have now gone full circle, back to that living room floor of ever so long ago. Which strikes me as a good stopping point.

Part 5. More Designs in AP-ART

My spacious and delightfully pleasant woodworking shop in a converted greenhouse in Lincoln has already been described and illustrated on pages 10 and 18. I carried on my puzzle craft there for thirty years. In 1998, finding myself living alone, I decided to move to Andover and live with Mary Dow. She allowed me to use her basement for my new workshop. I carried on there for thirteen more years. But in 2011 Mary's house had to be sold, and I moved to smaller quarters in a rental condo in Lexington. I again had the use of the basement, and still had most of my power tools. But by then in my early 80s, I decided to spend less time producing and more time having fun "inventing." I put that word in quotes because I sometimes think "discovering" is more appropriate. I often made only one of each new creation, hence the prefix X for experimental and the start of this new numbered list. Incidentally, I was forced to move again in 2016, but luckily only three doors away. My newest workshop is tiny and meagerly equipped by comparison, but I am still able to fashion at least some rough models for use in illustrating this *Compendium*.

There is considerable repetition in Part 5, especially involving variations of the *Scrambled Scorpius*. It is obviously one of my favorite designs. As already explained, my plan for this *Compendium* is to make it quite inclusive, since one can very easily skip ahead to something less scrambled if one wishes. In a future edition I might find some way to condense, but oh how hard that would be.

I originally issued this Part 5 in 2015 as a separate publication called *More Designs in AP-ART, The Sculptural Art That Comes Apart*. Note the absence of the word "puzzle." When I started all this fifty years ago, when asked what I did for work, I soon learned to not answer with "puzzles," for all too often I might then be asked, "jigsaw or crossword?" But if I offered a correction of "Oh no, 3D," still worse was then being asked, "Oh, do you make Rubik's Cube?" I decided that if I ever did another book about my work, I would avoid the word "puzzle" altogether. But of course that has proven to be impractical. When asked that same question about my work these days, I have learned to avoid all that by saying that I'm an artist. So of course the logical question I am then apt to be asked: "Oils or watercolor?"

One of my pastimes is composing lines of what some might call light verse, but I prefer to call poetry. With little likelihood of ever seeing a book of my verse published, in 2009 I hit upon an alternate scheme for dissemination. Thereafter, every design of mine used in an IPP puzzle exchange would be accompanied by one of my verses. There have been about a dozen so far. I sometimes spend as much time carefully crafting those lines as I do on the design itself. They sometimes offer helpful hints at solution, but more often just the opposite. I once compared ideas about poetry with Martin Gardner and found that we thought very much alike. Namely, to be most worth quoting and remembering, a well-crafted poem needs that special quality of rhyme and meter that lends itself to being sung, and perhaps even danced to.

English was the one subject I struggled with throughout my schooling. Perhaps it shows, as in my cryptic lines of description. But for me, putting words together into a harmonious whole, while leaving out all the unessential, can be as entertaining a challenge as the design itself. Composing these accompanying lines of text is rather like searching for the optimum design of an interlocking puzzle. Beyond my objectives of accuracy and clarity, I have also tried to convey my passion for the natural beauty of geometrical recreations - in my case polyhedral dissections. It is a doctrine that goes all the way back to the famed mathematicians and philosophers of ancient Greece, and their storied *Music of the Spheres*. Think of this *Compendium*, then, as my *Cantata of AP-ART*, and tune in to the music.

Most of the models shown on the remaining pages of this *Compendium* were made as experimental samples, often only one, which I seldom saved. So I am relying on photos supplied by others, or on models I have reconstructed, or at least tried to, from often sketchy records.

Design X-1. Six dissimilar, non-symmetrical pieces assemble essentially one way only to form a tetrahedral triangulation. Fairly simple, as things go - six center blocks, 12 identical long triangular end blocks (here in oak), and 12 identical shorter ones (here in redheart).



Design X-2. Six dissimilar non-symmetrical pieces interlock with tetrahedral symmetry. Assembly of one half is by coordinate motion; other half is interlocking. Disassembly is tricky too. Only a few made, this one in yellowheart, redheart, and walnut.

When six pieces are laid out for the photo like this and the above, you can generally assume that the puzzle slides together in two halves, top three with bottom three.



Design X-2-A. Despite the number, this design bears little similarity to X-2. Two were made in 2015, and mine somehow became lost and forgotten until luckily now resurfacing. I think it well merits inclusion. One half goes together by coordinate motion, and the other half is sort of interlocking, which is a rather nifty combination. And with all standard parts, fairly easy to make. All twelve poplar and twelve blue mahoe blocks are standard right-handed prism blocks, and the eight oak blocks are as marked.

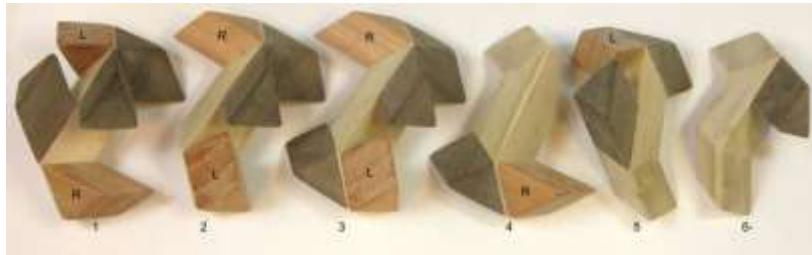

Design X-3. One of two made, this one in maple, oak, and redheart. Six dissimilar non-symmetrical pieces interlock with tetrahedral symmetry. Could be described as a further augmented Design #34-A. As usual, goes together in two halves. The 12 identical oak end blocks could be described as slanted square prisms, and the 12 redheart are standard right-handed prism blocks. Tricky to disassemble.



Design X-4. One of two made, this one in limba, with maple center blocks. Seven piece serially interlocking. This could be considered a reflection of *Fancy This!* #115-A. Pieces are arranged in order of assembly. First step of assembly is three-piece coordinate motion. See page 150 for details.



Design X-5. Here at last is a *Two-Tiers Puzzle*, described in Chapter 20 of *The Puzzling World of Polyhedral Dissections* but never actually made until recently. There are two solutions, depending upon where the loose block is either placed or left out. This is one of two made in 2014. Oak and maple. For more information, see #75-A. See also X-12.

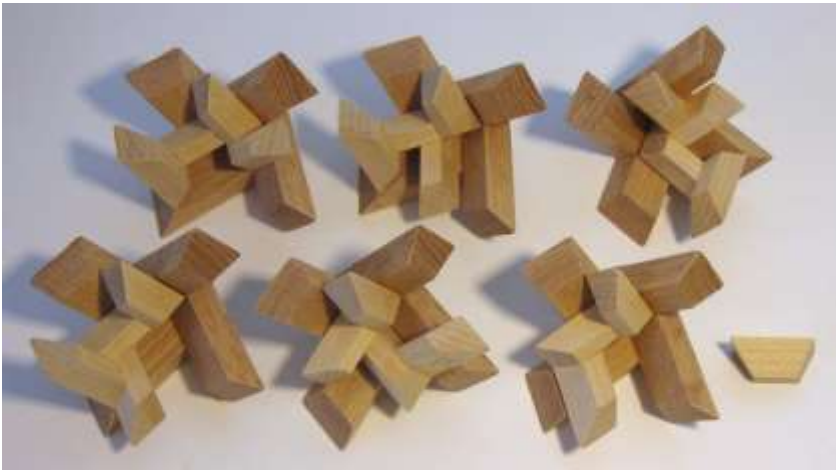

Design X-7. One-of-a-kind, six pieces, interlocking. Could be described as a *Garnet* #60 with the addition of 24 more identical blocks around the outside inverted. Here in oak and poplar. The solution is ABC-DEF, as described under *Garnet* and as arranged below.



Design X-8. A two-tiered design. The inner part is a *Garnet* #60, type ABC-DEF. Only two or three made; this one in poplar and maple. See also X-13.

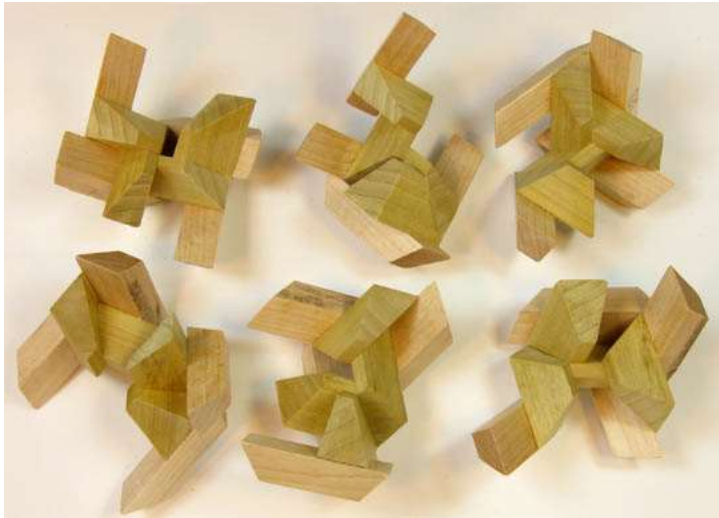

Design X-9. A unique triple-nesting design. Outer shell is 3-prong *Pennyhedron* in aspen plywood. Second layer is a *Garnet* #60, type ABC-DEF in oak. Innermost core is a *Garnet* type AFC-DEG in aspen. Rough model, and the only such triple combination I intend to make.



Design X-11. Yet another member of this two-layer family, with six dissimilar pieces that assemble by mating two halves. This rough model, one of two or three made, is in aspen.

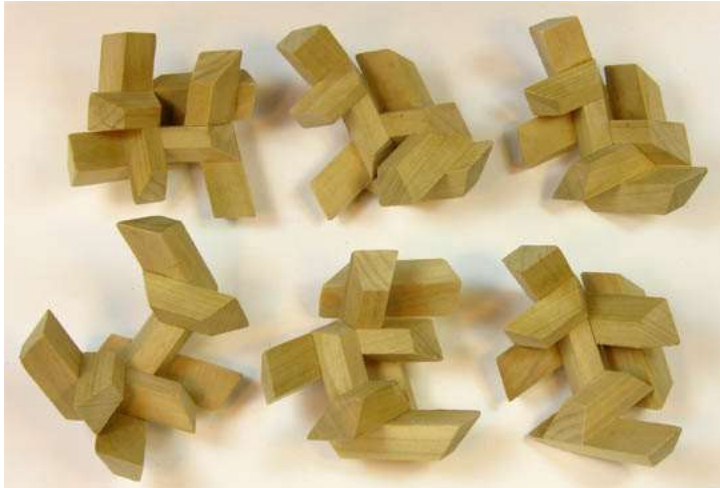

Note the similarity of X-11 to X-7. With X-11 the outer blocks are just a bit longer. Likewise X-8. Then why list those two as different designs? Because that little extra length imposes additional constraints on assembly, which is the whole idea. See also comments with X-13.

Design X-12. This is a re-issue of Design X-5, *Two-Tiers*, the only difference being the loose block being painted red. Oak and aspen. Only one made.



Design X-13. This model is in maple. You can't miss the close similarity of this one to X-8 and X-11. Not sure now why I listed them separately. But you may be able to see that there are slight differences in how the outer blocks are arranged, and they do illustrate the point that the possibilities for creativity here are practically unlimited. The arrangement determines and restricts the order of assembly. Of these three, X-8 is the most restrictive, which makes it my favorite.



Design X-14. A two-tiered construction. The outer shell is a variation of *Scorpius* #5 but made with sticks of rhombic rather than triangular cross-section. The inner layer is the ABC-DEF version of *Garnet* #60. One of two made, both in solid maple. The best way I have found to make these is to glue up the inner and outer parts separately and then glue them together while assembled (see #151 and X-21).

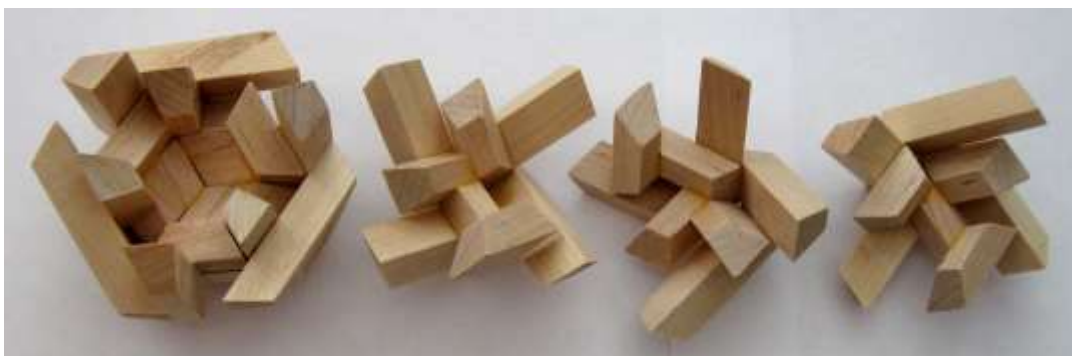

Split Star, Improved. Designs X-15 through X-20

These are all variations of the *Split Star* #165 series, with the outer layer attached by half faces. The stellations are canarywood. The inner core, of either aspen or maple, is a *Garnet* #60 in one of its many variations. These variations are identified by the pieces used, as shown at the bottom of this page.



X-15 and X-16 ABC-DEF



X-17 ABC-DEF



X-18 ABC-DEF



X-19 ACFG-DE



X-20 ABC-DEF



Design X-15 and Design X-16. Both are six-piece interlocking. Each could be described as a modified *Split Star*, Design #75, with same assembled shape but different pieces. The pieces shown here are for X-15; those for X-16 are slightly different. Made of canarywood, with aspen inside.



Design X-17. This is the first of four designs made by omitting some of the outer parts of the X-15 *Split Star*. Here four vertices are omitted to create a stellated square column. The inner part is a *Garnet* #60 in the ABC-DEF version. Canarywood and aspen.



Design X-18. The second of four designs made by omitting some of the outer parts of the X-15 *Split Star*. Here six vertices are omitted to create a stellated hexagonal column. The inner part is a *Garnet #60* in the ABC-DEF version. Canarywood and aspen.

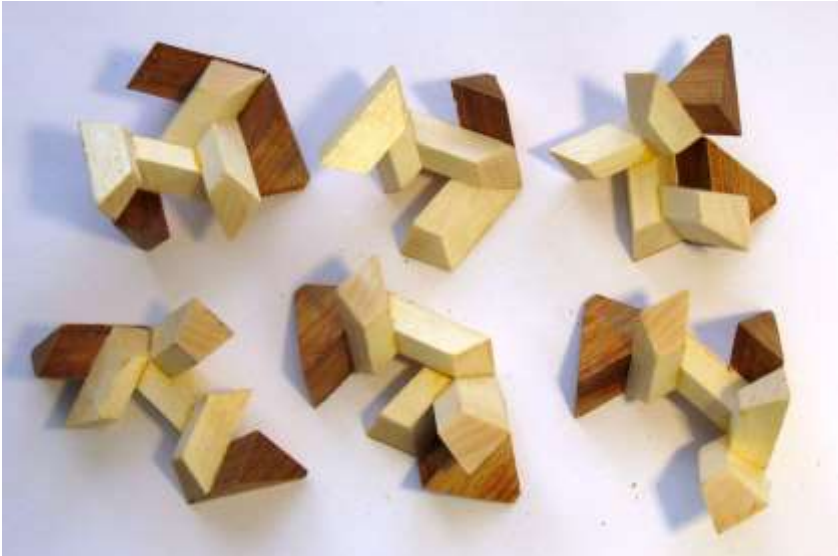

Design X-19. This is the third of four designs made by omitting some of the outer parts of the X-15 *Split Star*. Here only four vertices remain to create a squat octahedron. The inner part is a *Garnet #60* in the seldom used ACFG-DE configuration, and this may turn out to be the only instance used. Canarywood and aspen.



Design X-20. This is the last of four designs made by omitting some of the outer parts of the X-15 *Split Star*. Here six vertices remain to create a six-pointed star. The inner part is a *Garnet #60* in the ABC-DEF configuration. Canarywood and aspen.



Design X-21. Another two-tiered construction. The outer shell is a *Scorpius #5* but made with trapezoidal rather than triangular sticks. The inner part is the ABC-DEF version of the *Garnet #60*. But unlike Design X-14, it is solid rather than hollow. The outer shell is oak, the inner is canarywood. Note three pencil dots marking main axis.



Design X-22. This is an oversized, two-tiered variation of *Garnet* #60. The outer shell is a standard *Garnet*, type ABC-DEF. The inner 12 blocks restrict the order and direction of assembly, and also provide solidity to the completed assembly. The outer layer is oak, and the inner is maple. Only one made, and I did not record the exact arrangement, so use your imagination.



Designs X-23 to X-28. The next six designs are variations on what by now should be a familiar theme – two tiered construction with a *Garnet* #60 inside a *Scrambled Scorpis* #23. A draft version of this *Compendium* devoted six pages to them, and one might say boring pages. I have decided, instead, to explain in just a couple pages what the whole idea was.

The *Scrambled Scorpis* lends itself to being made with multiple contrasting woods, arranged symmetrically of course. There are four ways, as illustrated below. Most logical is all like woods *parallel*. Another simple scheme is four intersecting *rings*. Then there are *triangles* in opposite pairs. And finally we have the dreaded *super-scrambled*, the least obvious and of course my favorite.

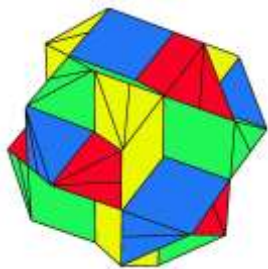

Parallel

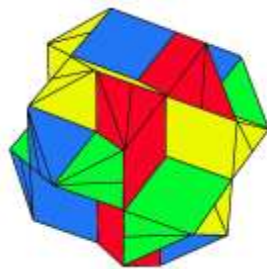

Rings

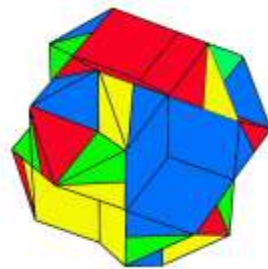

Triangles

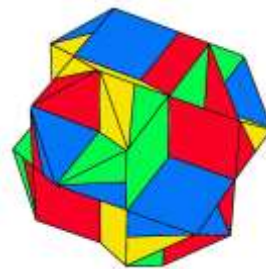

Super-Scrambled

There are also symmetrical arrangements using two, three, or six woods, but we will skip showing those. They are fun to figure out, and not difficult.

The inner layer of these two-tiered designs X-23 to X-28 is the by now familiar *Garnet* in one of its several forms, as already described. The form I have used most is ABC-DEF, which could be considered a *Scrambled Scorpis* inside-out. I have had fun making different combinations of inner and outer, but with nothing new to report here. So a brief description should suffice, and six pages are reduced to one. If you seek more details such as pictures of the pieces, they are more fully shown in some of my previous publications that John Rausch has now made available via Dropbox.

Design X-23. Another two-tiered construction. The shell could be considered a variation of the *Parallel* four-color *Scorpius* #164 but slightly truncated. The inner layer is a *Garnet* #60 in the ABC-DEF version.



Design X-24. A two-tiered construction. The outer shell is a slightly truncated version of the four-color *Scorpius* #5, but here in the less familiar *Ring* configuration. The inner is a *Garnet* #60 in the ABC-DEF version. The axis for the first step of disassembly is identified by the axis of symmetry of the red wood.



Design X-25. This is the second in a family of four two-tiered constructions. Here the outer shell is a four-color *Scorpius* #5 in the less common *Triangles* version. The inner is a *Garnet* #60 in the ABC-DEF configuration. The axis for the first step of disassembly is defined by the axis of symmetry of the light colored (oak) wood.



Design X-26. This is the third in a family of four two-tiered constructions. Here the outer shell is a four-color *Scorpius* #5 in the daunting *Super-Scrambled* configuration, the only one in which no like woods touch each other. The inner is a bastard *Garnet* in the newly discovered AFC-D+EC- combination. The axis for the first step of disassembly is defined by the axis of symmetry of the red wood (redheart).



Design X-27. This is the last in a family of four-wood two-tiered constructions. Here the outer shell is a four-color *Scorpius* #5 in the common *Parallel* version. The inner is a variation of the bizarre AB-CE-DH version of *Garnet* #60, discovered in 1984 but never actually made until now, and here modified slightly to permit two-tiered assembly. The axis for the first step of disassembly is defined by the axis of symmetry of the red wood (redheart).



Design X-28, the Spider-Slider Insider. This creation was an accident. I intended to make a four-color version of *Spider-Slider* #23 but did not have enough of one wood, so decided to make do using only three with a different sort of symmetry. Pleased with the result, I thought let's have some more fun by stuffing a *Garnet* #60 inside, and not just an ordinary one but instead the intriguing AB-CE-DH version. The woods offer no clue as to the sliding axis of disassembly.



Design X-29. This variation of *Split Star* is nearly identical to Design X-15 except for slight difference in two pieces and different woods. The red padauk tends to develop a blush that looks like mildew but isn't, and can be wiped off. Inside is a maple *Garnet* #60 in the often used ABC-DEF configuration.



Design X-30. This variation of *Split Star* looks identical to Design X-29, the difference being inside. This new and unusual variation of *Garnet* #60 uses one three-block piece and one five-block piece, as can be seen in the photo, and is identified by the code AFC-D+EC-. The outside blocks are padauk. The inside is maple..



Design X-31. This stellated hexagonal column bears a superficial resemblance to Design X-18, the difference being inside. The variation of *Garnet #60* used in the middle is identified by the code AB-CE-DH, discovered in 1984 but never used until now. It goes together in three confusing subassemblies rather than the usually assumed two halves. The red wood is padauk. The light wood is maple.



Design X-32. This is a novel variation of *Split Star #165*. It bears a superficial resemblance to Design X-20. However, the core is a *Garnet #60* in the unusual EF-CCDI variation, discovered in 1984 and here used for the first time. The confusing axis for the first step of disassembly is diagonal. Made of padauk and maple.



Design X-33. This is the third in a family of closely related designs created by judicious reduction of the 12-pointed *Split Star*. This unusual shape with three-fold symmetry is very likely unique in all puzzledom. In addition, the unusual *Garnet*-type core is described as type DE-ACFG, here used for only the second time. Of course the axis for the confusing first step of disassembly is diagonal. Made of padauk and maple.



Design X-34. This is another in the family of five closely related designs, created by judicious reduction of the *Split Star*. Here the shape is a squat octahedron. The core is the standard ABC-DEF version of *Garnet*, but the outer layer is designed to reduce the degrees of freedom, increase the amount of interlock, with of course a confusing diagonal axis of disassembly. Made of padauk and maple.



Design X-35. The last in the series of *Split Star* variations. I suppose the shape could be described as a stellated square column, or do like me and call it X-35. The core is what may now be familiar as the ABC-DEF version of *Garnet*. Note the diamond figure on each of the four sides. The woods are padauk and maple.



The Truncated Four-Color Scrambled Scorpius Family, X-36 to X-39. These are variations on what should be, by this time, a familiar theme, and more nearly examples of woodcraft rather than novel design. Therefore I am briefly summarizing all four on this and the next page.

These instructions apply to all four of these versions of the *Truncated Four-Color Scrambled Scorpius Family*. The original *Scrambled Scorpius* #23 provides the basis for this redesign. The six dissimilar, non-symmetrical pieces have only one mechanical solution. The use of four contrasting woods and the particular way they are joined together create these four different versions with polyhedral color symmetry. Note that the *Super-Scrambled Version* is the only possible arrangement in which no like woods touch each other.

The first step of disassembly, which separates the structure into two identical halves, requires no tools or excessive force, but just squeezing in the right places. I often mark the axis of disassembly by three tiny pencil dots. Furthermore, in these four one can look for the axis of symmetry of the light colored (maple) wood.

Design X-36. This is a truncated variation of the *Scrambled Scorpilus* #23, made with four contrasting woods arranged in the common *Parallel* version. Woods are maple, poplar, redheart, and granadillo. Joints are doweled.



Design X-37. This is a truncated variation of the *Scrambled Scorpilus* #23, made with four contrasting woods arranged as the less common *Ring* version. Woods are maple, poplar, redheart, and bocote. Joints are doweled.



Design X-38. This is a truncated variation of the *Scrambled Scorpilus* #23, made with four contrasting woods arranged as the less common *Triangles* version. Woods are maple, poplar, chakta viga, and purpleheart. Joints are doweled.



Design X-39. This is a truncated variation of the *Scrambled Scorpilus* #23, made with four contrasting woods arranged as the dreaded *Super-Scrambled* version. Woods are maple, poplar, chakta viga, and bocote. Joints are doweled.



Designs X-40 to X-43. These next four are what I call the *Double Play Duos*, one fitting snugly inside the other. Nothing really new or original here – merely having fun. So again I will just summarize them briefly, with more construction details available via the Dropbox links.

Design X-40. This is the first in a series of four *Double Play Duos*, which feature different versions of the truncated *Scrambled Scorpilus* on the outside, while contained within are different versions of the *Garnet*. This is the common *Parallel* version of the *Scrambled Scorpilus* in four contrasting woods, which are maple, poplar, chakta viga, and purpleheart. Joints are doweled. Only one made of this particular combo.



Design X-40-A. This is the inner amusement of the X-40 *Double Play Duo*. It is a *Garnet* #60 in the standard ACF-DEG version. It is made with six dissimilar woods – maple, lacewood, oak, redheart, rosewood, and an unidentified dark wood. The assembled photo provides clues to the solution.



Design X-41. This is the second in a series of four *Double Play Duos*, which feature different versions of the truncated *Scrambled Scorpilus* on the outside, while contained within are different versions of the *Garnet*. This is the less common *Ring* version of the *Scrambled Scorpilus* in four contrasting woods, which are maple, poplar, canarywood, and bocote. Joints are doweled. Only one made of this particular combo.



Design X-41-A. This is the inner amusement of the X-41 *Double Play Duo*. It is a *Garnet* #60 in the common ABC-DEF version. It is made with six dissimilar woods – maple, poplar, lacewood, bocote, redheart, and rosewood. The assembled photo provides clues to the solution.



Design X-42. This is the third in a series of *Double Play Duos*, which feature different versions of the truncated *Scrambled Scorpilus* on the outside, while contained within are different versions of the *Garnet*. This is the uncommon *Triangles Version* of the *Scrambled Scorpilus* in four contrasting woods, which are maple, poplar, chakta viga, and katalox. Joints are doweled. Only one made of this particular combo.



Design 42-A. This is the inner amusement of the X-42 *Double Play Duo*. It is a *Garnet* #60 in the seldom seen ABCDEH version. It is made with six dissimilar woods – maple, poplar, oak, redheart, rosewood, and granadillo. The assembled photo provides clues to the solution.



Design X-43. This is the last in a series of four *Double Play Duos*, which feature different versions of the truncated *Scrambled Scorpilus* on the outside, while contained within are different versions of the *Garnet*. This is the dreaded *Super-Scrambled* version of the *Scrambled Scorpilus* in four contrasting woods, which are maple, poplar, bloodwood, and bocote. Joints are doweled. Only one made of this unusual combo.



Design X-43-A. This unusual version of the *Garnet* #60 is the amusement contained within the also unusual *Super-Scrambled* version of the *Scrambled Scorpilus*. Unlike the usual *Garnet* and its several variations, this one has a two-block key piece (see X-49). Assembly involves coordinate motion. The assembled photo gives additional hints. Poplar, bocote, maple, rosewood, oak, and bloodwood.



Design X-44. This special version of the truncated *Scrambled Scorpilus*, unlike the usual multi-wood versions, is in all one wood, bocote, thus giving no hint as to the solution. Just a fancy version of *Egyptian #23-A* with doweled joints.



Design X-45. This is the first in a series of three versions of truncated *Scrambled Scorpilus* using three contrasting woods arranged symmetrically. Unlike the four-wood versions, this one does not make the solution too easy. But note, like woods are opposite. Woods are poplar, chakta viga, and katalox. Joints are doweled.



Design X-46. This is the second in a series of three versions of the truncated *Scrambled Scorpilus* using three contrasting woods arranged symmetrically. Call this one the *Three Ring* version. Matching like woods is a big aid in solving. Woods are maple, redheart, and bocote. Joints are doweled.



Design X-47. This is the third and last in a series of truncated *Scrambled Scorpius* variations using three woods (instead of the usual four) arranged symmetrically. This is clearly and delightfully the most scrambled of the three. If you can fathom the logic of the arrangement, it might help in solving. Joints are doweled. Woods are oak, redheart, and katalox.



Design X-48. This is a continuation of *Double Play*, begun with X-40, in which a *Garnet* is enclosed by a *Scrambled Scorpius*. Here the *Super-Scrambled* version is used. The axis for the first step of disassembly coincides with the axis of symmetry of the light colored wood (maple), providing you can visualize it. Woods are maple, poplar, rosewood, and chakta. Joints are doweled. The *Garnet* is a new version, identified as the *Double C, Three-Block Key*. In the photo of pieces, the bottom row includes, in addition to the new and unusual three-block key, two *Garnet* pieces of type C. Woods are maple, poplar, kauri, lacewood, rosewood, and bocote. Five made in April, 2014.

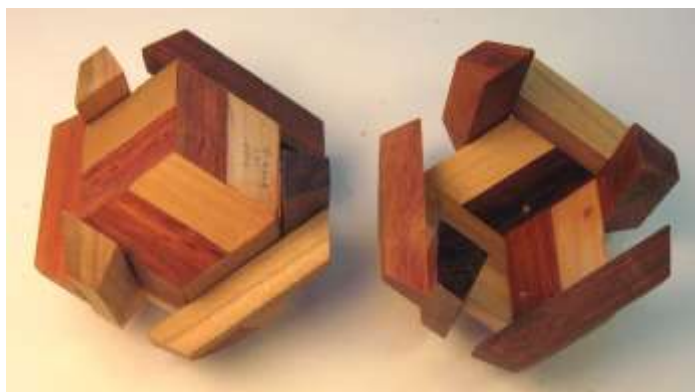

Designs X-49 to X-63 are all what I call *Double Play Duos*, in which a *Garnet* is enclosed by a *Scrambled Scorpion*. Preliminary versions of this *Compendium* contained photos and descriptions of each. But there is not much really new in the outer part, so I am skipping most of them here, and then showing the inner *Garnet* part only when it is a new design.

Design X-49. The outer layer of this *Double Play Duo*, not shown, is a *Scrambled Scorpion* in six dissimilar woods, one wood for each piece. The inner part is a *Garnet* likewise in six contrasting woods – maple, poplar, zebrawood, purpleheart, bocote, and chakta viga. This new and unusual serially interlocking design with unusual two-block key goes by the name of *Orange Key*, and this is one of only two made. A small indent can be seen on the key piece for easy removal. The key piece can also be spotted by the distinctive orange color of chakta viga. Order of assembly is left to right, top to bottom.



Design X-50. The outer layer of this *Double Play Duo*, not shown, is a *Scrambled Scorpion*. The woods are maple, poplar, bloodwood, bocote, katalox, and chakta. Joints are doweled. Only one made. The inner part of this unique combination is a *Garnet* in an unusual version identified as AB-CE-DH. It is the only known version that goes together with three two-piece subassemblies, as shown by the photo. Woods are maple, poplar, oak, redheart, bocote, and rosewood.



Design X-51. The outer layer of this *Double Play Duo* is a *Scrambled Scorpion* in an unusual arrangement of the six contrasting woods in what I call *Six Windmills*. The symmetrical color arrangement of the woods is a help in solving. The woods are maple, poplar, redheart, rosewood, bocote, and bloodwood. Joints are doweled. Only one made. The inner part of this unique combination is a *Garnet* in an unusual version identified as AB-CE-DH. It is the only known version that goes together with three two-piece subassemblies (see photo of X-50). Woods are maple, poplar, oak, redheart, bocote, and rosewood.

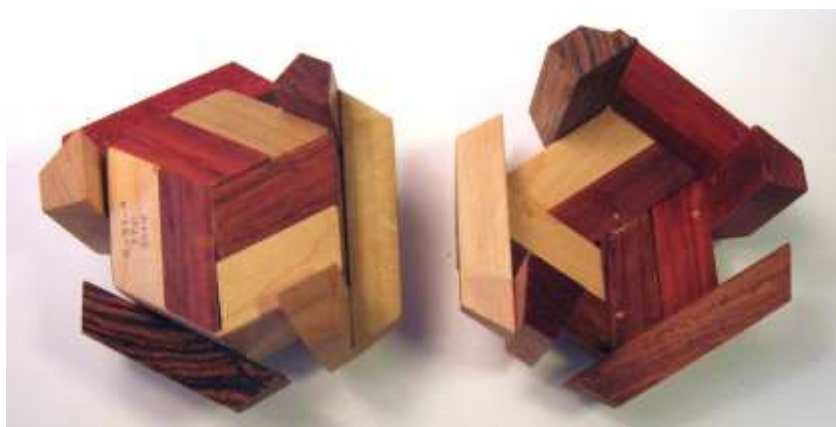

Design X-52. The outer layer of this *Double Play Duo* is a *Scrambled Scorpius* in an unusual arrangement of the six dissimilar woods that I call *Offset Windmills*. The symmetrical arrangement of the dissimilar woods might be a help in solving, but only after you have fathomed the logic of the arrangement. The woods are maple, poplar, oak, purpleheart, bloodwood, and rosewood. Joints are doweled. The inner part of this unique combination is a *Garnet* in the unusual version identified as AB-CE-DH. It is the only known version that goes together with three two-piece subassemblies (see photo of X-50). Woods are maple, poplar, oak, redheart, bocote, and rosewood.



Design X-53. The outer layer of this *Double Play Duo*, not shown, is a *Scrambled Scorpius* in six dissimilar woods, one kind of wood for each piece. The inner part is a *Garnet* in the unusual ACD+ EFG- version. Note the plus and minus signs, indicating a block removed from one piece (the key) and added to another (bottom center). The woods are maple, poplar, lacewood, redheart, bocote, and purpleheart.



Design X-54. This is the first in a series of four *Double Play Duos* in which the outer layer is a *Scrambled Scorpius* in eight dissimilar woods arranged symmetrically. I call this version *Eight Triangles*. The axis for the first step of disassembly is the axis of symmetry of the light colored woods, oak and poplar, and is also marked by the three pencil dots shown in the photo. Woods are oak, poplar, canarywood, chakta, purpleheart, bocote, redheart, and bloodwood. The joints are doweled. The inner part of this unique combination is a *Garnet* in the usual ABC-DEF version. Woods are maple, poplar, bocote, lacewood, redheart, and rosewood.



Design X-55. This is the second in a series of four *Double Play Duos* in which the outer layer is a *Scrambled Scorpius* in eight dissimilar woods arranged symmetrically. I call this version *Eight Parallel Triplets*. The axis for the first step of disassembly is the axis of symmetry of the maple and purpleheart pairing, and is also marked by the three pencil dots shown in the photo. Woods are maple and purpleheart, poplar and rosewood, canarywood and bloodwood, oak and redheart. The joints are doweled.



The inner part of this unique combination is a *Garnet* in an unusual variation that I call *Red Key*, and is one of two made (the other being used in *Design X-43*). Woods are maple, poplar, oak, bloodwood, rosewood, and bocote.



Design X-56. This is the third in a series of four *Double Play Duos* in which the outer layer is a *Scrambled Scorpius* in eight dissimilar woods arranged symmetrically. I call this version *Eight Rings*. The axis for the first step of disassembly is the axis of symmetry of the maple and purpleheart, and is also marked by the three pencil dots shown in the photo. Woods are maple and purpleheart, oak and redheart, canarywood and bloodwood, poplar and rosewood. The joints are doweled.

The inner part of this unique combination is a *Garnet* in an unusual variation that I call *Orange Key*. The indent of the chakta viga key piece is visible. It is one of two made. (For details see *Design X-49*). Woods are maple, poplar, zebrawood, purpleheart, bocote, and chakta viga.

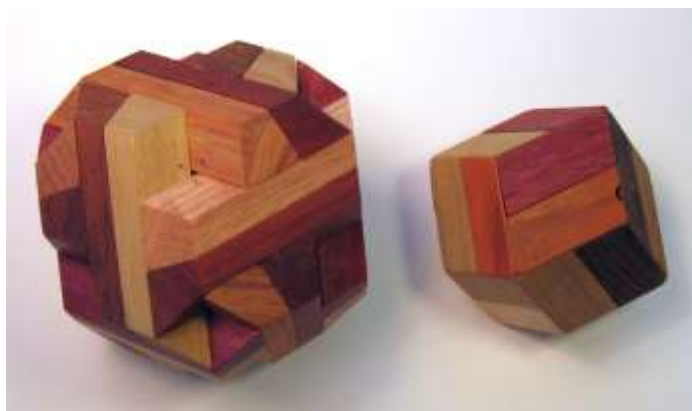

Design X-57. This is the last in the series of four *Double Play Duos* in which the outer layer is a *Scrambled Scorpius* in eight dissimilar woods arranged symmetrically. I call this version the *Double Super Scrambled*. The axis for the first step of disassembly is the axis of symmetry of the maple and poplar, if you can find it. Woods are maple and poplar, oak and redheart, canarywood and bloodwood, purpleheart and rosewood. The joints are doweled.



The inner part of this unique combination is a *Garnet* in an interesting combination that I call the *Lacewood Key* version. The first step of assembly is three-piece coordinate motion, and the remaining three steps are all non-linear. It is one of two made, the other being used in *Design X-58*. The woods are maple, poplar, zebrawood, purpleheart, bocote, and lacewood.



Design X-58. This is the first of two *Double Play Duos* in which the outer layer is a *Scrambled Scorpius* in twelve dissimilar woods arranged symmetrically. I call this version *Twelve Matched Pairs*. Unlike most others, the woods give no clue as to the first step of disassembly. However, the axis is marked by three pencil dots. Woods are maple, zebrawood, poplar, bloodwood, oak, granadillo, canarywood, redheart, rosewood, walnut, bocote, and lacewood. Joints are doweled.

The inner part of this unique combination is a *Garnet* in the interesting combination that I call the *Lacewood Key* version. (See X-57 for details). The woods are maple, poplar, zebrawood, purpleheart, bocote, and lacewood.



Design X-59. The outer layer of this *Double Play Duo* is a *Scrambled Scorpius* in twelve dissimilar woods arranged symmetrically in what I call *Opposite Pairs*. Since the woods give no clue as to the first step of disassembly, the axis is marked by three pencil dots. Joints are doweled. The wood pairings are an aid to reassembly, once you figure out the plan.

The inner part of this combo is a *Garnet* in an interesting *Serially Interlocking* design that was first called *Lacewood Key* but is here renamed because multiple woods are now used. The six dissimilar woods are arranged in the *Offset Windmills* pattern. The woods are maple, poplar, redheart, oak, walnut, and an unidentified sixth wood. Three of this unusual combination were made.



Design X-60. The outer layer of this unusual *Double Play Duo* was a *Scrambled Scorpius* in six dissimilar woods arranged in the *Offset Windmills* pattern. The inner part of this combo was a *Garnet* in the recently discovered *Serially Interlocking* design using six dissimilar woods likewise arranged in the *Offset Windmills* pattern. Nothing really new here, so we can skip the photos for this and the next two.

Design X-61. The outer layer of this unique *Double Play Duo* was a *Scrambled Scorpius* in six dissimilar woods arranged in the *Offset Windmills* pattern. The inner layer was a *Garnet* in the recently discovered serial interlocking version called *Lacewood Key*.

Design X-62. The outer layer of this unusual *Double Play Duo* was a *Scrambled Scorpius* in six dissimilar woods arranged in the *Offset Windmills* pattern. The inner layer was a *Garnet* in the unusual AB-CE-DH version.

Design X-63, Reflection. This *Double Play Duo* is so named because the inner and outer layers could be regarded as exact reflections of each other. Both are described as the ABC-DEF version. In the bottom photo the pieces are so arranged, left to right, top to bottom. The inner and outer layers both assemble by mating two identical halves. The axis for the outer layer is marked by three pencil dots. Six dissimilar woods are used for the *Scrambled Scorpius* outer layer, with a different set of six dissimilar woods for the *Garnet* inner layer. Both are arranged in the *Offset Windmills* pattern.

The name *Reflections* could have a double meaning, for as I look back over fifty years of geometric explorations, the *Scrambled Scorpius* was one of my earliest and most satisfying discoveries. Look at all the mileage we have gotten out of it over the years.



Design X-64. This is an unusual and unique seven-piece variation of the *Scrambled Scorpilus*. It goes together in two dissimilar halves. One half assembles by coordinate motion and is then locked together by a one-stick key piece. For many years I have been trying to design a serially interlocking *Scrambled Scorpilus* with key piece, and this is at least a small step in that direction. The other half also involves coordinate motion, and can be assembled only if some edges and corners are rounded. Pieces 6 and 7 are identical. This one is in African mahogany.

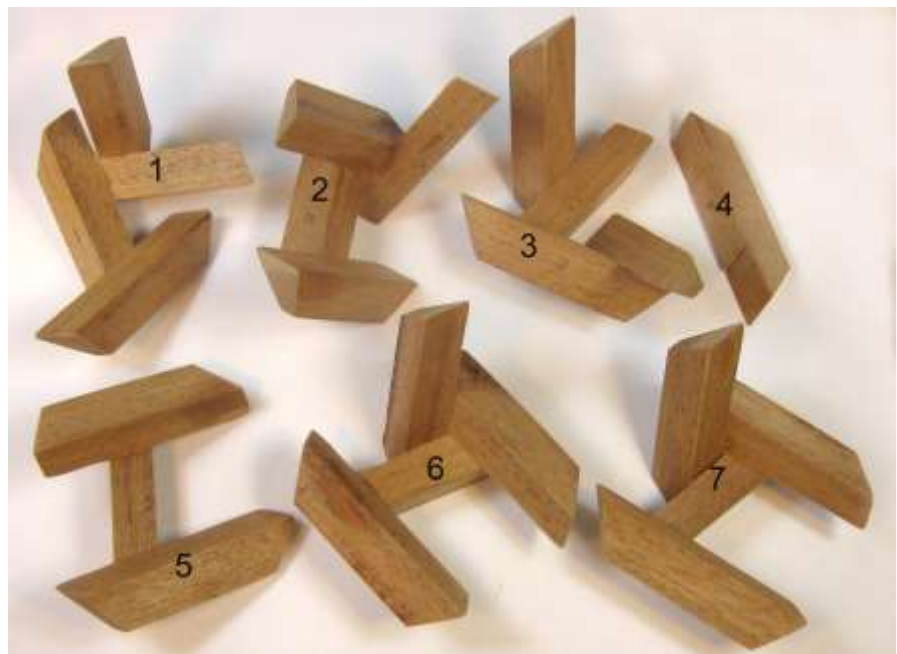
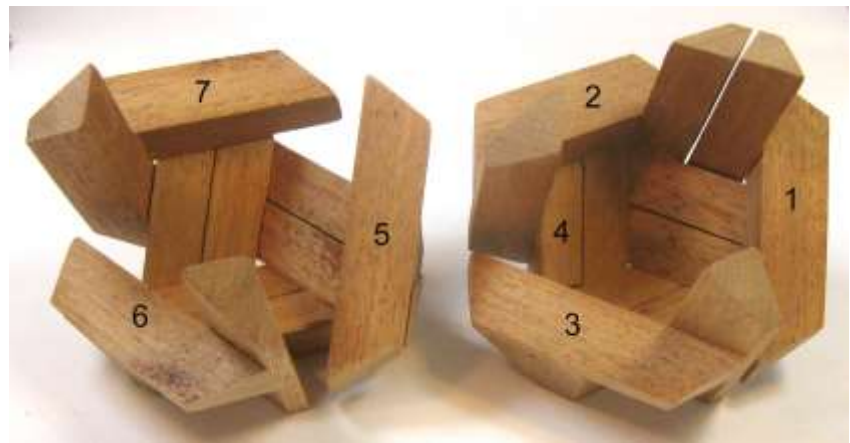

Design X-65. This is an unusual variation of *Scrambled Scorpius* that uses six identical pieces, designated piece C in my notation (see page 48). It assembles by mating two identical halves. Each half assembles by coordinate motion, thus reminiscent of the baffling *Three Pairs* #27. Since the six identical pieces are easily glued using a special glue jig, and since the four identical trapezoidal cross-section sticks that comprise each piece are easily milled using standard woodworking tools, it would be an easy one to produce. I made one a few years ago using some scrap pieces. But now here is another dressed up in mahogany. The second photo shows one half assembled and one half apart. Unfortunately this model requires either some force or rounding of corners and edges to assemble, so it cannot be considered a proper design, geometrically speaking.



Design X-66. This design has a history. My first polyhedral creation in wood, the *Spider-Slider* #5, was made in late 1970. About 20 were crudely made of stained basswood and sold for \$10 each. One of them surprisingly turned up recently (see page 23). In 1971, I produced an improved version called *Scorpius* in four contrasting hardwoods. I was granted U.S. Design Patent #230288 for it in 1974. A variation called *Dislocated Scorpius* #16 first appears in my 1974 sales brochure, with the price inflated to \$12.

I look back at the day I found the unique solution for the six dissimilar non-symmetrical pieces of what became known as *Scrambled Scorpius* #23 as one of my luckiest discoveries of this whole adventure. My design notes, if they ever existed, are now lost, but the first recorded sale was November 1977, by which time I was using choice woods such as Brazilian rosewood. I made and sold about 250.

Over the years I have tinkered with possible variations using fewer or more pieces, seeking especially a genuine serially interlocking assembly. I am now nearly convinced that no such design is possible. However, of all my recent experiments in this continuing search, Design X-66 comes closest. (See details on next page.) I made six, using up scraps of maple and poplar. And now here is one more, but this time in mahogany, made especially to pose for the camera.



First step. Combine pieces A, B, and I (see plans for most pieces on page 48). This may be the only practical version known to me that uses the I piece.

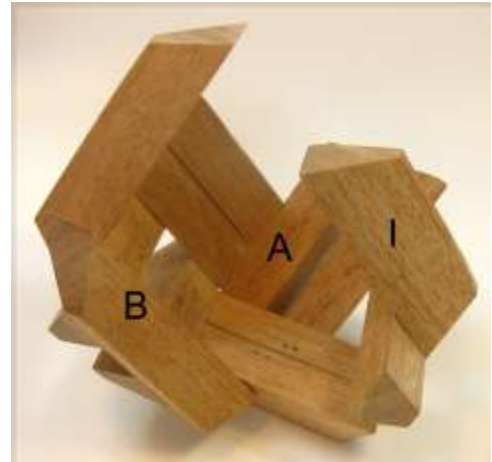

Second step. Combine pieces C and E.



Third step. Combine the two subassemblies, by holding loosely and gently working them together. No force is required for this coordinate motion step, nor is any rounding of edges or corners required either. The triangular piece is gently worked into the remaining space the same way, and the key single bar is inserted to complete the assembly.

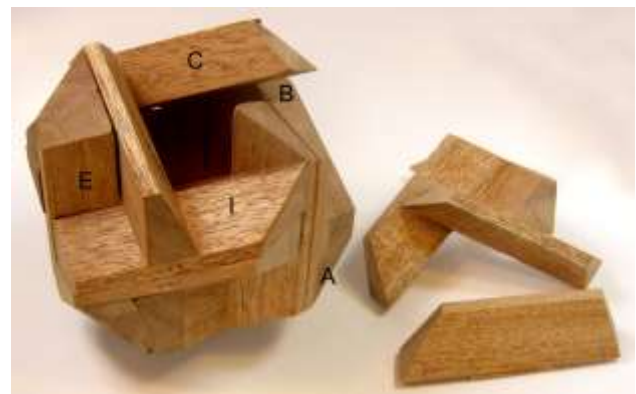

Whew! Perhaps time to close the book on this captivating chapter and move on.

Design X-67 and X-68. These are variations of *Distorted Cube* #61-A using spheres in place of edge-beveled cubes. Both use the usual four dissimilar pieces. The two dissimilar rectangular boxes restrict the solutions to only one for each box. Note that the box on the left is deeper than the other. The one-inch maple balls are doweled together for strength. I made one of each.



Assembly of X-69, Hex-Tic

Hex-Tic was a double-size variation of *Hexsticks*.

1. Form a triangular nest using two regular pieces and one three-notch piece. Then stand two regular pieces upright.
2. Add three more pieces in a ring around the outside. The piece partly hidden on the left (first photo) is a three-notch piece. The other two are regular.
3. Wiggle a regular piece into position on top. Combine the remaining three-notch piece with the one-notch piece and insert them in the direction shown.
4. Insert the un-notched piece vertically to complete the assembly.



Design X-70. Inside the Jar. Four identical round dowels made of one-inch oak, with slanted round notches slightly off-center, go together with tricky coordinate motion one way only to fit snugly inside the 8-ounce plastic jar.



Design X-71-A. Snugly Fit. This is the preliminary version of *Snugly Fit* that fits snugly inside a 10-ounce plastic jar. The six dissimilar pieces plus locking pin are shown below in order of assembly. Made with 1/2-inch walnut dowels and 1/4-inch maple pins.



Design X-71. Snugly Fit. Showing at top an improved preliminary version of X-71-A in plastic jar, but here made with 3/4-inch oak dowel and 3/8-inch aspen pins. And below, the final improved version X-71; same pieces but in hexagonal plywood box with cover. For design of the six pieces and locking pin, see previous page, noting that the length of each of the pieces is critical for a snug fit with these all dissimilar pieces.



Design X-72-A. Up or Down.

Preliminary version of X-72 in plastic jar. Uses 3/4-inch walnut dowels with deep notches that are drilled at an angle of 85 degrees. Three of the pieces are identical, and the other three are their mirror image.

X-72, Up or Down



Design X-72. Up or

Down. Improved final version, made with one-inch oak dowels and enclosed in hexagonal plywood box with cover.



Design X-73. Pineapple Pile

This is a variation of my Design 62, *Nine Bars*, with round dowels in place of hexagonal sticks. Also the angle of the holes is changed from 70 degrees to 77 degrees, giving it a more upright shape.

It is assembled one way only with pieces in the order shown. The first step of assembly with the two identical small cross pieces and plain dowel is shown. After that, the pieces are easily inserted in the only way possible, with the locking pin completing the assembly.

I have made five of these in March, 2015, to use up surplus 3/4-inch walnut dowel stock. The 5/16-inch pins are aspen.

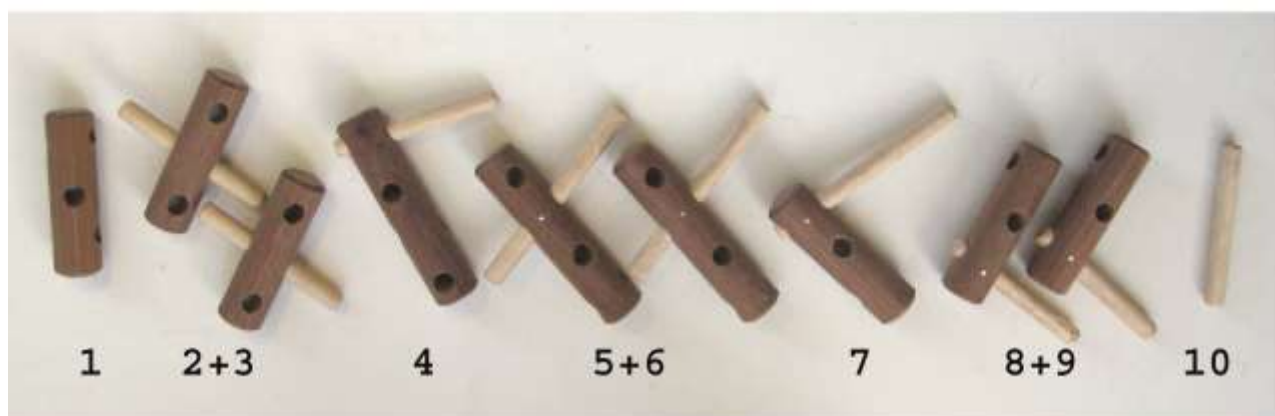

Design X-74. Lollipop. It consists of 12 pieces and a cubic box to contain them, as shown below. The pieces are made from edge-beveled 1.25-inch cedar cubes. Each such block has holes drilled on two adjacent edges. One hole goes all the way through; the other one doesn't. A 3/8-inch maple dowel is fastened into the blind hole. Depending on which hole has the dowel gives rise to two mirror-image kinds of pieces, which we could arbitrarily call right-handed and left-handed. There are six of each. There is also a cubic box of 1/4-inch Baltic birch with one-inch cubic blocks, not shown, fastened inside the bottom four corners. The cover also has four such blocks.

The object is to discover how many different constructions can be made with various numbers and combinations of pieces. Below are shown a few examples, which we might call Triangle, Tetrahedron, Hexagonal Ring, and finally the complete set of twelve to fit into the box. Many other interesting constructions await discovery. Some have multiple solutions.

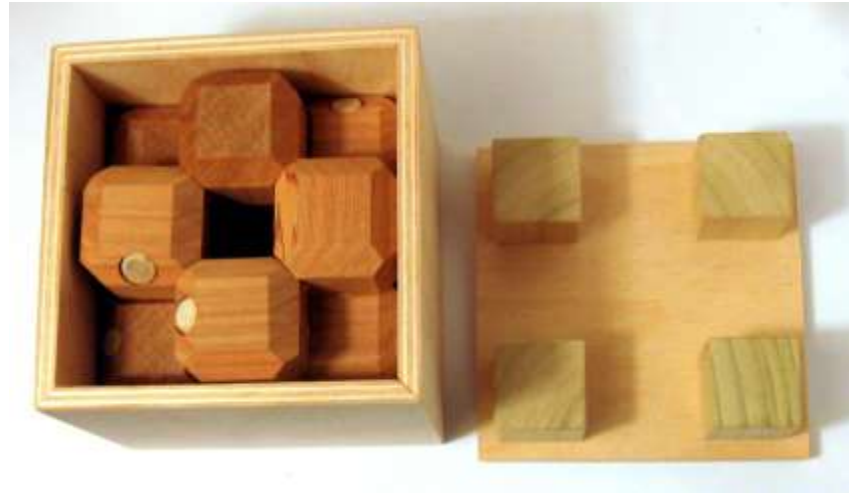

Design X-74-A. This could be considered a variation of *Lollipop* X-74 using 1.5-inch maple balls in place of edge-beveled cubes. Again there are two kinds of pieces, and again each ball has two holes, one blind and one all the way through. Into the blind hole again goes a 3/8-inch maple dowel. But there the similarity diverges. Two of the balls have holes drilled at 90 degrees to each other, and the other four balls have holes drilled at 60 degrees. They plug together essentially one way only to fit snugly into the hexagonal box made of 1/4-inch Baltic birch. Other playful constructions may also be possible.

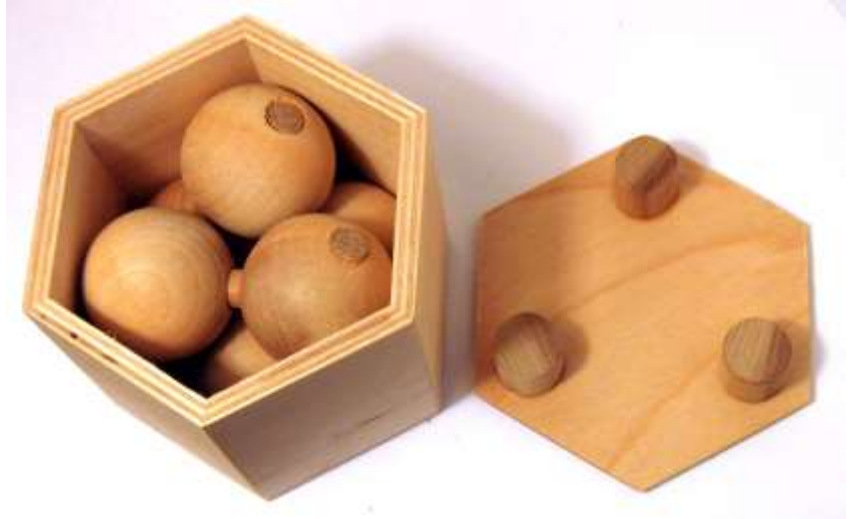

Design X-74-B. This one could be described as a simplified variation of X-74-A. Four identical pieces assemble one way only to fit snugly into the cubic box. The two holes are drilled at 60 degrees to each other (see X-74-A). The 1.5-inch balls and 3/8-inch dowels are maple, and the 1/4-inch plywood box is Baltic birch. One novel feature is that the solution requires coordinate motion, as shown in the second photo.



Design X-74-C. Play Ball! This one is quite similar to X-74-A. Again there are four balls drilled at 60 degrees and two at 90 degrees. But the maple balls are now one-inch and the box is rectangular with a sliding cover. On the next page is the accompanying instruction sheet, with a bit of my version of humor tossed in. I had assumed that the pieces packed into the box one way only, symmetrically as show. But Nick Baxter discovered a second solution, not strictly symmetrical.



Design X-74-C, Play Ball!

The original plan was for six identical lollipops to construct all of the assemblies shown below, plus probably others yet to be discovered, and finally to fit inside the rectangular box. Unfortunately, my helper, Karl S. Lee, is prone to error. Some of the lollipops may not be identical. Karl refused to correct this, claiming that they would still work. So you be the judge. For added recreation, imagine how each of these figures could be constructed with six identical pieces.



1. Diamond. This is the easiest; just a practice exercise.



2. Triangle. Also easy. Involves simple coordinate motion.



3. Could be called a triangular pyramid or tetrahedral pile of four lollipops.



4. Call this four-lollipop construction what you wish; perhaps a basket. It has a two-fold axis of symmetry.



5. An octahedral pile made with six lollipops. It has the symmetry of a cube, with three four-fold axes of symmetry.



6. This cluster of six lollipops (one hidden underneath) has the symmetry of a brick, with three two-fold axes of symmetry.



7. This cluster of six lollipops has four three-fold axes of symmetry. Now where have we seen this before?

8. Now fit the six lollipops into the box.

STC, 2015

Design X-75. Doubleplay. I have made *Doubleplay* X-75 in several slightly different styles.

On the left is the original 2015 version with the six dissimilar pieces of 5/8-inch poplar, as shown, and box with novel cover of maple. In the center is a more recent scaled up version, likewise in poplar but 3/4-inch, with box of Baltic birch. On the right is the most recent version, with pieces of 3/4-inch maple and box of multi-colored woods. Cover of limba, blue mahoe, and padauk, and box of aspen plywood. The name *Doubleplay* comes from the two tasks – finding the one solution to the 3x3x3 cubic assembly, and then figuring out how to get the darn thing into the box, both difficult. But in keeping with my reformation, I give you the solution.



X-75 ASSEMBLY

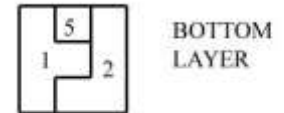
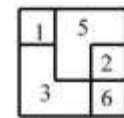
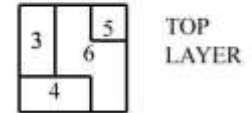
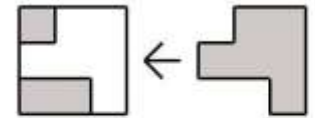

- Piece 1 goes in by rotation
- Piece 2 goes in by rotation
- Piece 3 goes in by multiple shifts
- Piece 4 goes in by two shifts
- Piece 5 goes directly in
- Piece 6 goes directly in

Design X-76. Thirteen cubic blocks are joined to make three pieces that assemble one way and in one order only to form a solution with three-fold symmetry. As usual, the assembled blocks have their grains all running in the same direction. This is done mostly to minimize the effects of change in humidity, but perhaps it looks nice too, as well as being a decided aid in solving.



Design X-77. This is the first of three in the X-77 family. The four pieces are supposed to all fit inside a cubic box with cover. If the cubic blocks are size $2 \times 2 \times 2$, then the box is $6 \times 6 \times 6$. Note that the box has some $1 \times 1 \times 3$ blocks attached on four edges. Also the cover has $1 \times 1 \times 1$ blocks attached to the four corners, which stabilize the cover, but more importantly also block unwanted multiple solutions. Consequently there is only one solution. With puzzles of this sort, you can go crazy checking for possible unwanted solutions among the hundreds of possible arrangements, and even then you are left with doubts. But instead I use the generally reliable Puzzlesolver3D program to be sure. Solution is shown. Warning: the solution involves rotation, and some edges may need to be slightly rounded. Note the pencil markings on the pieces. These are so I can assemble it myself. I don't have much patience trying to solve my own puzzles when I would much rather be doing something else, so I routinely mark the solutions, usually erasing them before they are sent out to friends, depending.

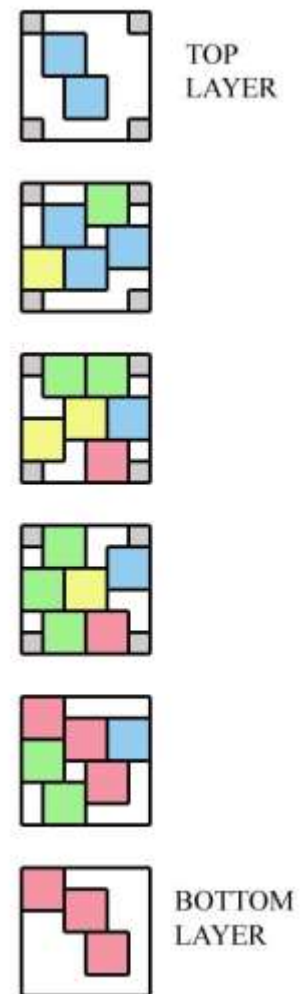
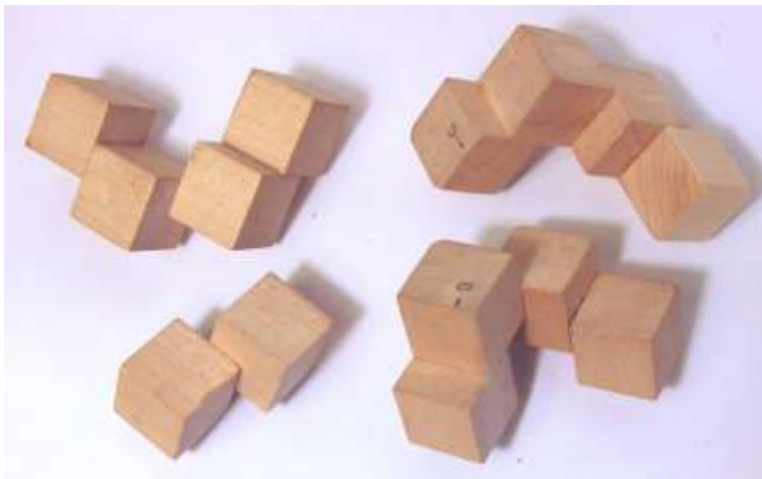
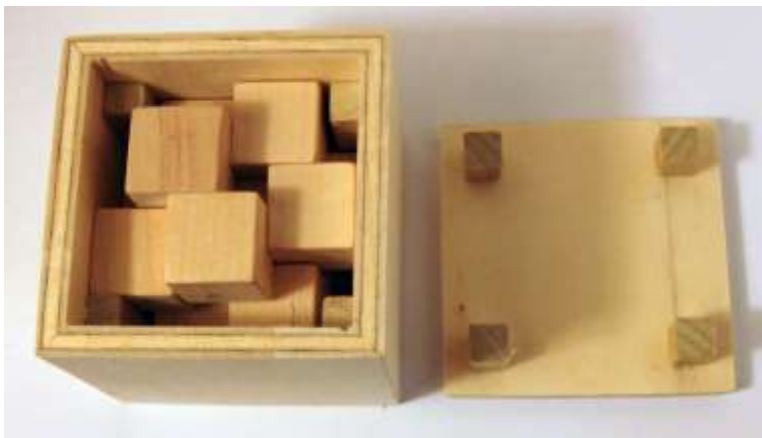

Design X-77-A. Do Drop In. Three simple pieces made up of ten cubic blocks joined together different ways form three dissimilar pieces, one of which is symmetrical. The solution does not require close fit, so the grain of the blocks can run randomly. The task is to fit them into the square box and close the cover. Ah, but there are a couple problems. The cover requires some extra space around the rim, and the box has some restrictions also. If the dimensions of the blocks are $2 \times 2 \times 2$, then that rectangular block in the bottom is $1 \times 2 \times 3$, the cubic block above it is $2 \times 2 \times 2$, and the box is $6 \times 6 \times 5$. I impishly withhold the solution on this one, for now at least, but look for a hint in the name.



Design X-77-B. Are You Kidding?

This is the third and perhaps best of three in the X-77 family. The four pieces, which are identical to those in X-77, are supposed to all fit inside a cubic box with cover. If the cubic blocks are size $2 \times 2 \times 2$, then the box is $6 \times 6 \times 6$. Note that the cover has $1 \times 2 \times 3$ blocks attached to two opposite corners, and the box has a $2 \times 2 \times 2$ block attached. There is only one solution, and most computer programs will probably report that this puzzle is unsolvable. The solution involves two rotations, so some edges may need to be slightly rounded.

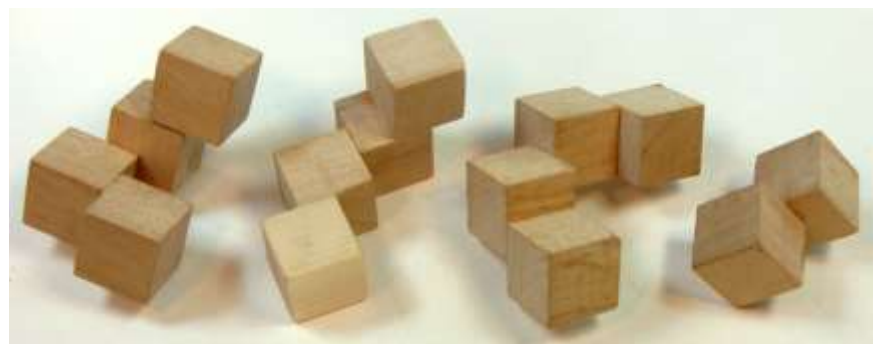

Design X-78. Close inspection reveals that all six pieces are dissimilar and non-symmetrical (not counting the pin). There is only one solution and essentially one order of assembly. The small plug stuck in one end of one of the cross pieces and the corresponding shortening of the locking pin are what make all this possible. This model is in $\frac{3}{4}$ -inch oak hex with $\frac{3}{8}$ -inch oak pins. It may look like several of the preceding designs, but this is the first to combine these various features all into one.



Design X-79. This one may bear a superficial resemblance to Design X-78, but that is misleading. It is actually a revival and improvement of *Double Cross* #240, but with hexagonal oak sticks in place of round walnut dowels. Also the ends of the sticks have been tailored to fit snugly inside the hexagonal box, which has the important effect of making all pieces dissimilar and non-symmetrical. Altogether a most satisfactory design. The parts are arranged in order of assembly, left to right, top to bottom.



Design X-80. Four and Twenty. While puzzling what to do with some leftover good quality walnut dowel stock, I came up with the idea for this unique one-of-a-kind AP-ART sculpture. It consists of twenty-four drilled $\frac{1}{2}$ -inch walnut rods and twenty-four $\frac{1}{4}$ -inch birch pins. It has thirteen axes of symmetry (same as a cube). None of the pins are attached; all are free to slide. Given the photo of the assembly, it should not be very difficult to disassemble and reassemble.

And now for a confession: In my haste to produce as many models as possible, with my time running short, I do not always take great pains for accuracy, especially with this type. I have found it easy to correct any slight misalignment of the holes by reaming through at assembly using a round rasp, $\frac{1}{4}$ -inch in this case, in a variable speed reversible electric drill.

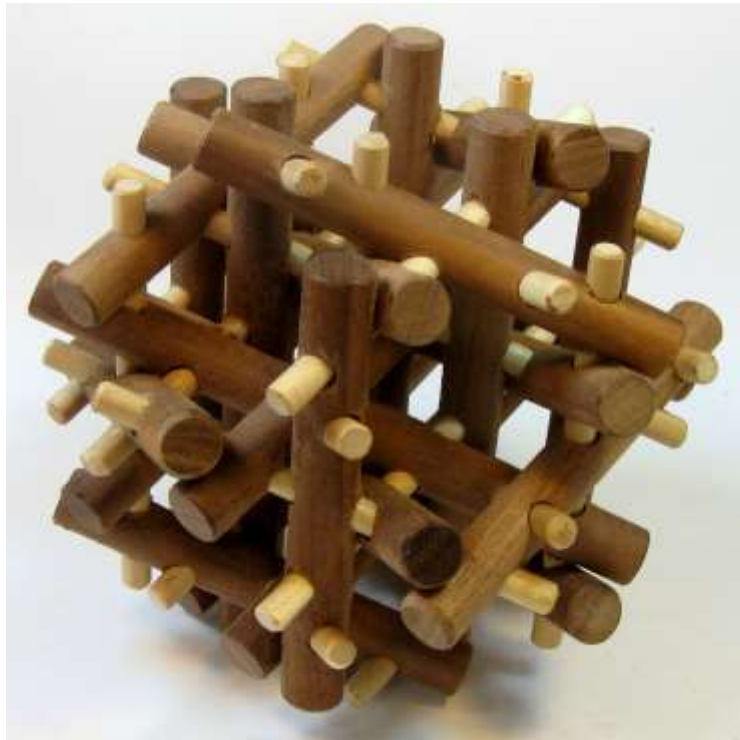

Design X-81. This one bears a superficial resemblance to a few others, especially *Double Cross* #240. But it is different, and an improvement I think. Six dissimilar non-symmetrical pieces, only one solution, and essentially only one order of assembly. Try to beat that. It is actually a variation of Design X-78, but using round $\frac{3}{4}$ -inch walnut dowels in place of hexagonal sticks, and $\frac{3}{8}$ -inch maple pins. The pieces are arranged in order of assembly, left to right, top to bottom. For a name, I suppose it could be called *Running Out of Ideas*. But not quite yet. Two more to go.



Design X-82. Reversion. Back in my time, children loved to play with wooden blocks, and I especially. (I hope they still do, but one has to wonder in these times.) I never got over it. The first two puzzles that I list in this *Compendium* involve wooden blocks, and here we complete the circle, but this time with the relatively new novelty of cubes joined by quarter and half faces, and now looking for simple designs that may have been previously overlooked. And lo, up pops the nineteen-block octahedron. Does a five-piece design exist with all dissimilar non-symmetrical pieces and serial interlock? I spent weeks searching and was nearly convinced of its impossibility, until finally finding this one. Made with $\frac{3}{4}$ -inch maple cubes, it just happens to fit snugly into a Uline 10-ounce clear plastic jar. And look, I even provide the solution, and with colored pieces for good measure. But brace yourself for one final test.

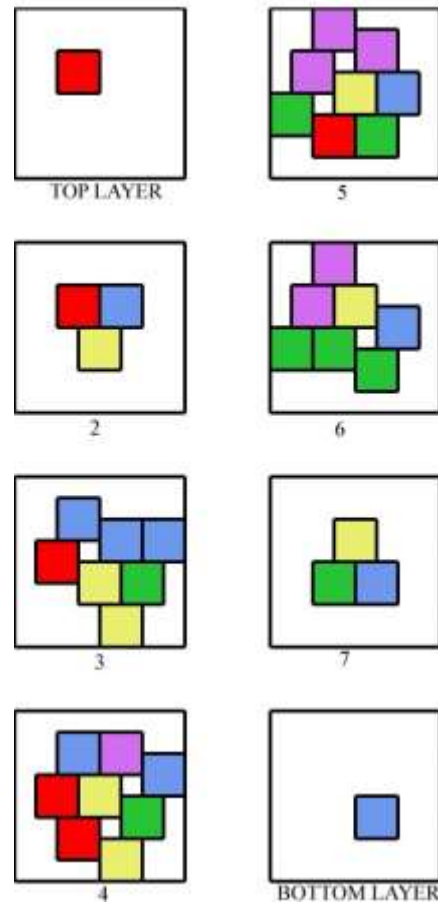
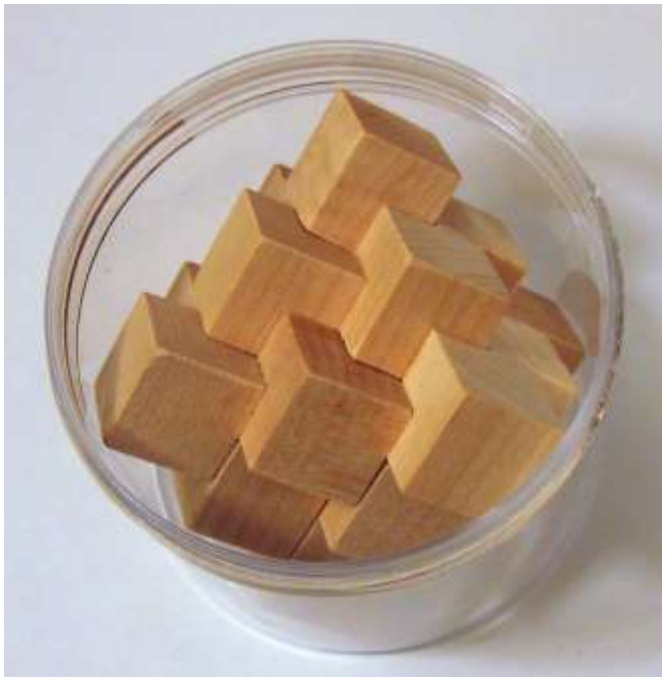

Design X-83. Final Exams. With the success of *Reversion X-82*, I began wondering what else, and more specifically if nineteen was the maximum number of blocks that would fit into that 10-ounce jar. It then dawned on me that twenty should also fit. Only problem then - see if a practical design can be found. This involved an even more exhaustive search than for X-82. But I finally did find one, and I take some pride in my discovery. I think it deserves a better container than that plastic jar. So here it is nesting snugly in a hexagonal box of Baltic birch. Blocks are maple. This same hexagonal box also works for X-82.

But there is more. I purposely omit the design details for this one. After all, X-82 ought to suffice for workshop plans. I challenge puzzle analysts to determine how many 20-block designs exist, assuming mine is not the only one. I will be most interested to know. But remember, five dissimilar non-symmetrical pieces with true serial interlock, and no compromise. No easy task.

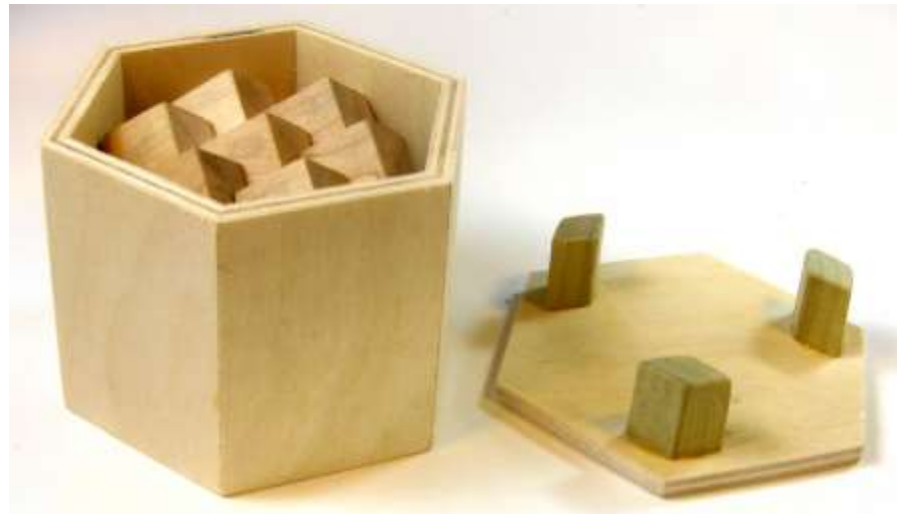
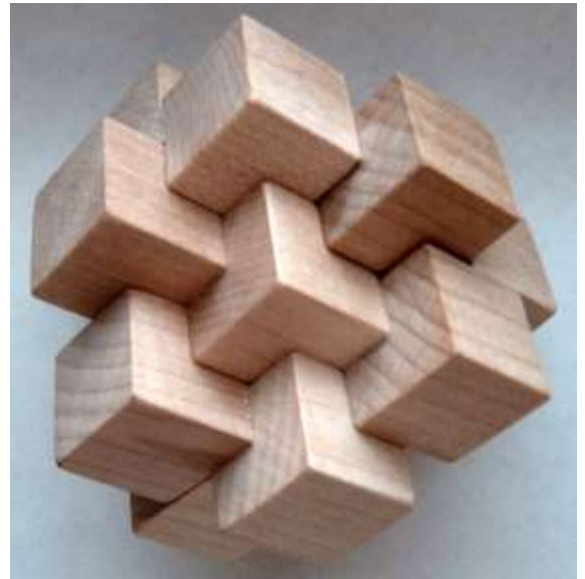

Parting Shot

I had the strangest dream the other night. As I gingerly approached The Gates, I found myself confronted by Saint Peter with his dreaded entrance exam in hand.

“Well my son,” he asked, “what have you to show for the life you have led?”

And I replied: “Well, I suppose I did have a hand, so to speak, in bringing three wonderful daughters into the world.”

“Yes, we know all about that. Anything else?”

“Not a helluva a lot. Oh well, I do like to think of myself as the creator of AP-ART.”

“Sure, we know all about that too. But of what significance might that be in terms of overall human destiny?”

“Ah yes, I’ve often wondered about that myself. I truly gave it my best effort. I suppose only time will tell.”

“Good answer. And I see you’ve brought some of your creations along with you. Might we have a look?”

He takes a look.

“I wonder if we might have a simple one to play with here at The Gates when times get slack. How about that one? It certainly appears to be the easiest of the lot.”

So I handed *Martin’s Menace* to Pete (disassembled of course), continued on my way, and vanished into oblivion up amongst the clouds.

Appendix Part A - Polyhedral Building Blocks

Many of the polyhedral puzzles described in this *Compendium* are constructed using what I call standard building blocks. In the drawings of the individual pieces these blocks are identified as follows:

T for Tetrahedral Block

P for Rhombic Pyramid Block

R for Right-Handed Prism Block

L for Left-Handed Prism Block

Δ for triangular sticks of various lengths

C for Six-Sided Center Block

The first five building blocks listed above can all be made by cross-cutting a stick of equilateral triangle cross-section on a table saw, using a special jig to hold the stick at the correct angle of feed. Even those with no inclination for woodworking may find this description of the process useful as an aid to grasping the geometry of the various blocks.

Figure 1 shows the special Triangular Stick Saw Jig in use. As viewed from above, the angle of the cradle relative to the saw blade is 54.7 degrees. After each saw cut, the triangular stick is advanced and rotated forward 1/3 turn for the next; thus the Tetrahedral Blocks **T** are made without waste. They are not regular tetrahedrons – all six faces are identical isosceles triangles, two of the dihedral (between faces) angles are 90 degrees and the other four are 60 degrees.

The Rhombic Pyramid Blocks are made with the same setup except that now the triangular stick is advanced farther and rotated *backward*. The Rhombic Pyramid Block can be visualized as two Tetrahedral Blocks joined together. They are likewise produced without waste.

The Prism Block comes in two varieties that are mirror images of each other. To make the Left-Handed Prism Block **L**, the same setup is used, the triangular stick is advanced still farther and not rotated between cuts. The Right-Handed Prism Block **R** can be made using a saw jug that is the

mirror image of the one shown, but an easier way is to use the same saw jig with the addition of a triangular stick spacer. These blocks are likewise made without waste.

The symbol Δ indicates a triangular stick segment of various length, usually cut on the diagonal using this same saw jig, but sometimes cut squarely off on one end.

The Six-Sided Center Block **C** is made from square stock using a different saw jig (Figure 2) that cradles the stick at 45 degrees and feeds into the saw at 45 degrees as seen in top view, likewise without waste.

Tetrahedral Blocks **T** and Rhombic Pyramid Blocks **P** can also be made from square stock using the 45-degree saw jig, but not so easily, and with waste. This results in the wood grain running in a different direction, which may be desirable in puzzles such as the Star #4-A. Both Right-Handed Prism Blocks **R** and Left-Handed Prism Blocks **L** are readily sawn from square stock without waste.

Another building block, less commonly used, is the Squat Octahedron Block **O**. It is made from square stock with waste and can be visualized as a Six-Sided Center Block **C** with both ends trimmed off, or as two Rhombic Pyramid Blocks **P** fastened together back-to-back. Figure 3 summarizes how these various blocks are made from either triangular or square stock.

Rhombic dodecahedron blocks are sawn from square stock using the 45-degree saw jig. The first four cuts bring the end of the stick to a point. It is then advanced a precise distance for the final four saw cuts. The first three of these cuts are made only partway through, so that the block remains attached. Even so, the final one or two cuts are tricky, and some clamp (other than your fingers!) needs to be provided to hold the block safely and securely in place. The same approach but with different special saw jigs is used to make edge-beveled cubes or truncated octahedral, starting with cubic blocks. I never came up with a practical method of sawing out regular octahedral or regular dodecahedral blocks and did not use them in my work.

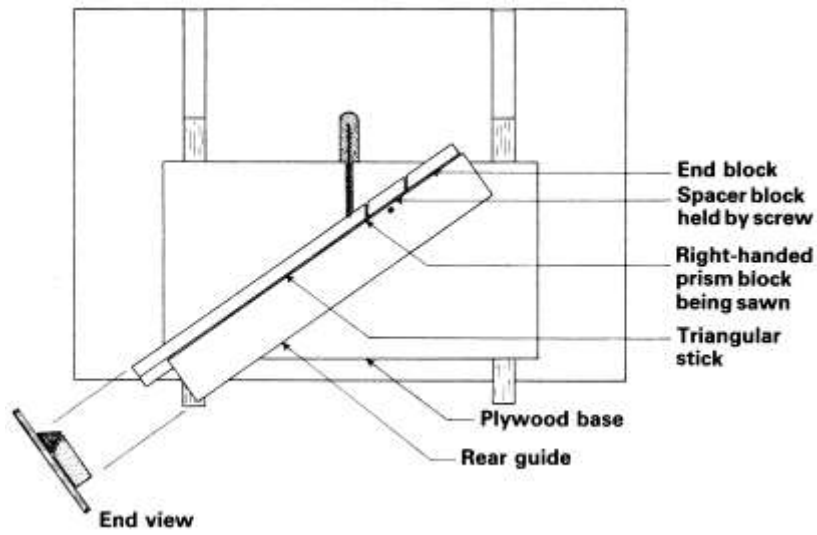

Figure 1

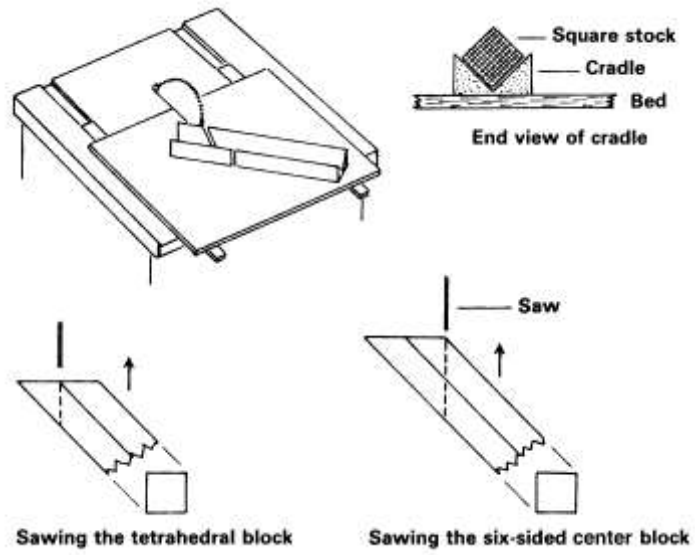

Figure 2

APPENDIX A — BUILDING BLOCKS

Most of the designs based on the diagonal burr have puzzle pieces fashioned from polyhedral blocks derived from dissections of the rhombic dodecahedron. If the geometry of these pieces is not entirely clear to the reader from the drawings alone, some hands-on experience with the blocks should help to clarify things. If the requirement for accuracy is set aside for the moment, they are all easy to make, even with hand tools.

For our purposes, the tetrahedral block is taken as the most basic unit, although of course it could be further subdivided

ad infinitum. Many of the blocks are made equally well from either square or triangular stock

Many of the drawings refer to the building blocks by their letter designation (i. e. **T** for the tetrahedral block).

Many designs also use triangular stick segments of various lengths.

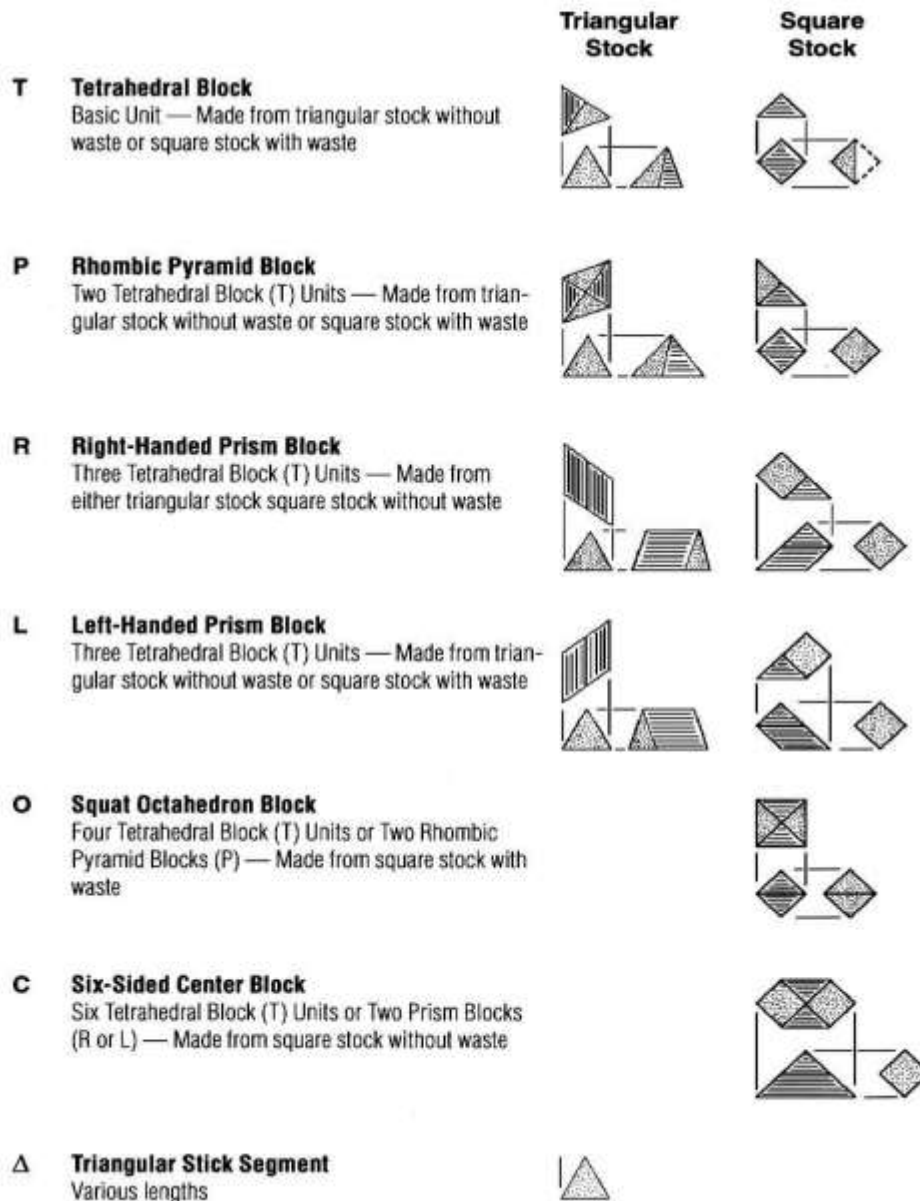

Figure 3

Appendix Part C – Glossary

Listed here are some terms that I have adopted for describing certain aspects of my AP-ART puzzle designs. You will not likely find most of them explained in any dictionary, at least not yet, but who knows – perhaps someday.

Coordinate Motion: Describes the situation in which two or more interlocked puzzle pieces must be moved in separate directions simultaneously in the process of assembly (and of course disassembly). Example: *Rosebud* #39.

Ghost Solution: Describes the situation in which the pieces would fit together and constitute a solution except there is no way to assemble them into their proper location because of mutual interference in getting them there. See *Sixticks* #268.

Incongruous Solution: An unexpected and unwanted solution to a combinatorial puzzle that does not lend itself to discovery by systematic trial and error because not all of the pieces conform to the intended logical, orderly layout but are instead scrambled in disorderly fashion. See *Octet in F* #268.

Serially Interlocking: This describes the situation in which pieces of an interlocking puzzle can be assembled (and of course disassembled) in one order only. Example: *Convolution* #30. I adopted this term in the early days of my work around 1970, and I am pleased to see that it is now catching on.

Symmetry: Considerations of symmetry are important in AP-ART. At several places in this *Compendium* I have described puzzle pieces as being symmetrical or non-symmetrical. There are many meaning of the word “symmetrical,” but I should explain that for shorthand I use it in a restricted sense to describe a shape that remains the same when rotated less than a full turn. For solids, that would be rotated about an axis of symmetry, and for flat pieces rotated about the point of symmetry. Two-fold, three-fold, and so on refers to the number of stops to complete a full turn - two for a rectangle, three for an equilateral triangle, four for a square, and so on. For a circle I suppose infinite-fold. And of course non-symmetrical is a shorthand term I frequently use to describe flat or solid shapes not having rotational symmetry, thereby maximizing the number of possible combinations in the pieces of a combinatorial puzzle.

Polyhedral Symmetry: This term as I use it describes any shape having identical non-coplanar axes of symmetry. All the Platonic solids have it. Examples: *Star* #4-A, *Scorpius* #5, *Four Corners* #6, *Jupiter* #7. Strictly speaking, polyhedral refers to a solid enclosed by plane faces, but I have chosen to use it in a broader sense to include any assemblage of geometric solids. Example: *Locked Nest* #22.

Reflexive Symmetry or Mirror Image Symmetry: You may find this term explained in some mathematical resources. I have used it in a few places in this *Compendium* to describe the relation between two geometric shapes or color patterns, either flat or solid, when one appears identical to the other when viewed in a mirror. See *Nova* #8-B.

Clockwise, and Counterclockwise: When two subassemblies of three pieces each fit together to complete an assembly, I often refer to the two halves arbitrarily as Clockwise and Counterclockwise. This usually refers to the way that the center blocks slant, as shown here.

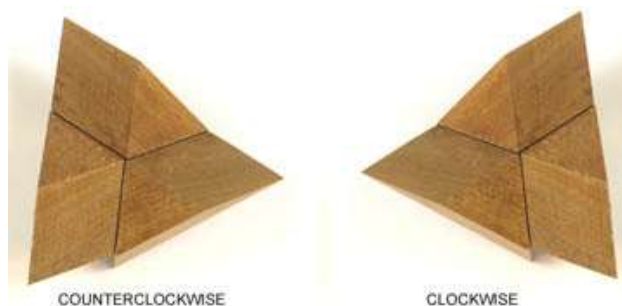

Appendix Part D – Additional Resources

My previous puzzle books:

Puzzle Craft 1985

Puzzle Craft 1992

The Puzzling World of Polyhedral Dissections, 1990, 1991

Geometric Puzzle Design, 2007

Books and magazine articles by others that mention my AP-ART:

A Yankee Way with Wood, Phyllis Meras, 1975

Creative Puzzles of the World, van Delft & Botermans, 1978

Puzzles Old & New, Slocum and Botermans, 1986

Fine Woodworking, The Taunton Press, 1987

New Book of Puzzles, Slocum and Botermans, 1992

The Lighter Side of Mathematics, Guy and Woodrow, 1994

The Book of Ingenious & Diabolical Puzzles, Slocum and Botermans, 1994

Exploring Math Through Puzzles, Zhang, 1996

The Mathemagician and Pied Puzzler, Berlekamp and Rodgers, 1999

Mathematical Properties of Sequences..., Kluwer Publishers, 2003

Tribute to a Mathemagician, A K Peters Pub., 2005

The Pea and the Sun, Wapner, 2005

Crafting Wood Logic Puzzles, Self and Lensch, 2006

Puzzle Projects for Woodworkers, Boardman, 2007

Het Ultieme Puzzelboek, Slocum and Botermans, 2007

A Lifetime of Puzzles, A K Peters Pub., 2008

Wooden Puzzles, Brian Menold, 2016

Actual Puzzles

I am aware of four locations where well over 100 actual models of my puzzle designs, made by myself and others, are now located.

The Lilly Library, located at 1200 East Seventh Street, Bloomington, IN 47405, houses the *Jerry Slocum Mechanical Puzzle Collection* of over 30,000 mechanical puzzles and related books and manuscripts. The collection has a permanent exhibit in the Slocum Room of highlights from the overall collection. The majority of the puzzles in the collection are available for use in the Lilly Library's Reading Room. Included in the collection are most of those listed in Part 3 of this *Compendium*.

The Puzzle Museum is located in England and is presently operating, from my perspective, primarily as a website at: <https://www.puzzlemuseum.com>. Over 10,000 puzzles have been catalogued and classified, representing 140 years of continuous puzzle collecting by ten people.

A collector in California now has what I believe to be the most complete collection of my puzzle designs, but they are in private hands and not open to the public.

I presently have what is probably nearly as complete a collection as the one above, with about 300 models, not counting duplicates. They are labeled and stored in sixteen large boxes, and this *Compendium* can serve as their catalog.

A search on the Internet turns up a few more listings described as puzzle museums, but I know nothing about them. One usually thinks of museums in terms of inaccessible items to be viewed from a safe distance, such as in glass cases. That strikes me as not only impractical with puzzles, but contrary to the whole idea. Much better would be the opportunity to take apart and play with. But what museum could possibly have the staff to put them all back together again, and the shop resources to replace the inevitable lost or broken pieces? Nor can I imagine inviting the public in to pour through my storage boxes, and I expect the same applies to the large collection in California.

So what is the alternative? Publishing. That is the whole idea behind this *Compendium*. I realize that it is incomplete, some of the descriptions may be unclear, and the photography might have been better. But I have done the best I could under the circumstances, and at least it represents what I hope will be a step in the right direction. Perhaps others can someday improve upon it.

Index

- Abbie's Waffle 41
- A-B-C 146
- Abel's Chimney 157
- All Star 128
- Amelia's Puzzle 197
- Anchored Tetrahedron 242
- Archimedes Tile 159
- Are You Kidding? 293
- Aries 15
- Arm in Arm 198
- Atlas 236
- Augmented Four Corners 62
- Augmented Second Stellation 37
- Augatron 140
- Ball Joint 241
- Ball Octahedron 222
- Ball Room 203
- Basket Case 220
- Blocked Box 204
- Block Lock 215
- Box Rebellion 202
- Brickyard 69
- Broken Sticks 60
- Burr #305 64
- Burr Circus 151
- Burr Muda 147
- Burr Noodle 139
- Butterfly 210
- Button Box 79
- Buttonhole Puzzle 70
- Case Closed 228
- Castle 191
- Cetus 15
- Checker 169
- Checking In 219
- Check Me Out 232
- Checkout 169
- Chicago 198
- Christmas 2001 192
- Christmas Tree 243
- Clock Wise 235
- Cluster-Buster 73
- Cluster Plus 149
- Cluster's Last Stand 154
- Coffin's Improved Burr 64
- Colorful Cornucopia 188
- Combination Lock 161
- Computer Killer 200
- Concentrix 133
- Confessional 95
- Confessional Plus 97
- Contrary Cover 204
- Convolution 57
- Corner Block 84
- Cornucopia 106
- Cracked Egg 233
- Crooked Notches 130
- Crystal Blocks 92
- Cruiser 187
- Cube 16 211
- Cube Brute 17
- Cuboctahedral Blocks and Pins 248
- Cuckoo Nest 46
- Decoy 195
- Defiant Giant 80
- Design No. 72 99

Diagonal Cube 83
 Diamonds 240
 Disinclination 133
 Dislocated Jupiter 40
 Dislocated Scorpius 40
 Distorted Cube 87
 Dodecahedral Blocks and Pins 249
 Do Drop In 293
 Double Cross 224
 Double Four-Legged Stand 114
 Double Play 194
 Doubleplay 291
 Double Star 15
 Double Hexagonal Prism 31
 Double Notch 130
 Double Triangular Prism 34
 Drop Out 207
 Dudd 162
 Edge-Beveled Cubes and Pins 249
 Egyptian 49
 Egyptian Plus 178
 Eight Elbows 224
 Eight-Piece Tangram 176
 Eight Star 36
 Eighty-Four 117
 EL-Gate 214
 EL-Hole 214
 Engelberg Square 166
 Expanding Box 89
 Extra Holes 227
 Fancy That 205
 Fancy This! 150
 Few Tile 164
 Figure Eight Puzzle 71
 Final Exams 299
 Five-Hole Dowel-Pin 247
 Five-Hole Pentacage 246
 Five-Piece Garnet 173
 Five-Piece Octahedral Cluster 59
 Five-Piece Solid Block 110
 Five Woods 189
 Foul Dowel 141
 Four and Twenty 296
 Four Blocks in a Box 197
 Four-Color Cube 14
 Four-Color Hexsticks 51
 Four-Color Octahedron 15
 Four Corners 24
 Four Fit 218
 Four-Legged Stand 113
 Fourpence 234
 Four-Piece Pyramid 52
 Four-Piece Separation 122
 Four-Piece Serially Interlock Cube 126
 Fourteen-Piece Square 173
 Fourteen Steps 196
 Fourth Dimension 127
 Frantix 13, 29
 Fusion-Confusion 39
 Garnet 85, 182
 Geodynamics 120
 Giant Hexsticks 51
 Giant Pagoda 81
 Giant Steps 30
 Grand Cross Variation 44
 Grizzly Burr 129
 Half & Half 221
 Half-Hour 56
 Hectix 12
 Helsinki 209

Hexagonal Prism 30
Hexcuse Me 188
Hexsticks 51
Hex-Tic 281
Hole-in-One 78
HO HO 111
House Party 229
Housing Project 192
Improved Cluster-Buster 74
Improved Corner Block 84
Incongruous 136
Inside the Jar 282
Interrupted Slide 68
Involute 217
Involution 204
Isoprism 135
Isosceles 135
Isosceles II 168
It's a Knockout 215
Joined Pairs 41
Jupiter 25
Keeping Company 242
Knife Attack 174
Lean-2 231
Leaning Tower of Altekruise 96
Lemon 171
Lime 171
Little Giant Steps 80
Little Rocket 124
Little Superstar 76
Locked Nest 46
Locked Nest Pile 47
Lock Nut 139
Logs & Sticks 227
Lollipop 287
Long & Short 45
Looking Glass 193
Lost and Found 143
Lucky Star 144
LUV 197
Make Room 160
Margie's Marvel 201
Martin's Menace 218
Meteor 134
Missing Notches 162
Missing Piece! 137
Monarch 209
Multi-Grain 244
Multiple Choice 208
My One and Only 189
Nest Construction Set 113
Nine Bars 88
Nine-Hole Dowel-Pin 247
Nine-Hole Pentacage 246
Nine Pairs of Trapezoids 156
Nine-Piece Pentagon 155
Nonesuch 140
Nothing to It 232
Nova 27
Obstructed Pins 117
Octagon 168
Octahedral Cluster 58
Octahedron 168
Octet in F 233
Octo 14
Octo Burr 142
Ortho-Cube 19
Out-Back 218
Outhouse 164
Overdrive 152

Pagoda 81
 Patio Block 115
 Peanut 93
 Pennydoodle 94
 Pennyhedron 77
 Pennyhedron Tricky Pair 79
 Pentablock 19
 Pentacube 20
 Pentagonal Stand 116
 Pentagonal Star 155
 Pentastic 237
 Pentasticks 237
 Permutated Four Corners 125
 Pieces-of-Eight 108
 Piggy Box 167
 Pillars of Hercules 109
 Pineapple 172
 Pineapple Pile 286
 Pin-Hole 43
 Play Ball! 289
 Playpin 45
 Please Drop In 176
 Plus 2 82
 Pluto 14
 Polly-Hedral 212
 Pool Puzzle 164
 Pretty Puzzle 110
 Prism 14
 Prism Cell 199
 Pseudo-Notched Sticks 88
 PuzzleSolver 214
 Pyracube 42
 Quadrilateral 123
 Quadrille 223
 Queer Gear 125
 Quintet in F 231
 R-D-16 158
 Rectangular Faces 131
 Redemption 136
 Reflection 277
 Restricted Area 241
 Reversion 298
 Rhombic Blocks 156
 Rhombticks 239
 Ring of Diamonds 35
 Rock Pile 157
 Rosebud 67
 Rosebud Assembly Jig 67
 Saturn 50
 Scorpius 24
 Scrambled Legs 182
 Scrambled Scorpius 48, 183
 Second Gear 126
 Second Stellation 37
 Setting Hen 87
 Seven-Hole Dowel-Pin 247
 Seven-Hole Pentacage 246
 Seven Irregular Hexagons 165
 Seven-Piece Hexsticks 179
 Seven-Piece Third Stellation 101
 Seventeen-Block Tree 242
 Seven Woods 69
 Shape Shift 211
 Shouldered Scorpius 186
 Sirius 22
 Sixes and Sevens 167
 Six of Diamonds 163
 Sixticks 238
 Slant Six 132
 Sleeper-Stopper 70
 Sleeping Viper 226

Slider 162
 Sliding Cover 203
 Sliparoo 148
 Slocum-Pokum 141
 Slot Machine 193
 Snowflake 21
 Snugly Fit 283
 Spare Parts 226
 Sphinx 177
 Spider-Slider 23
 Spider-Slider Insider 263
 Spinner 13
 Spiritus 15
 Split Box 196
 Split Star 103
 Split Star, Improved 258
 Split Star, Simplified 184
 Square Dance 217
 Square Face 102
 Square Knot 28
 Square Route 207
 Star 23
 Star Dust 145
 Star of David 65
 Stew's Scrap Pile 159
 Stucksticks 98
 Sunrise 208
 Sunrise-Sunset 190
 Super Frantix 29
 Super Nova 36
 Super Sleeper-Stopper 70
 Superstar 75
 Supersymmetry 229
 Tall Block 216
 Tangram Plus 165
 Tauri 15
 Tech Sticks 138
 Tectonic 163
 Teddy Burr 129
 Tetrahedron 15
 The Cube 19
 The Fox 208
 The General 34
 The General, Alternate Version 35
 The Hill 213
 The Outcast 220
 The Park 212
 The Rattle 222
 The Trap 175
 Third Stellation 75
 Thirty Notched Pentagonal 90
 Thirty Notched Rhombic Sticks 91
 Thirty Pinned Pentagonal Sticks 112
 Thirty Triangular Sticks 245
 Three Bunnies 153
 Three-Hole Dowel-Pin 247
 Three-Hole Pentacage 246
 Three Pairs 54
 Threepence 234
 Three-Piece Block 66
 Three-Piece Cross 16
 Three-Piece Separation 122
 Too Hard 225
 Topological Puzzles 70
 Total Eclipse 228
 Tray Bien 202
 Triangular Prism 32
 Triangular Prism, Alternate 33
 Tricky Tree 243
 Triful 17
 Trillium 140
 Triple Cross and HO-HO 111

Triple Play 201
Tripp's Puzzle 213
Triumph 38
Triumph Companion 39
Truncated Cluster-Buster 73
Truncated Octahedra 55
Truncated Tetrahedron 244
Try Angles 230
Twelve-Piece Separation 118
Twelve Point 61
Two-Sided Tray 123
Two-Three 113
Two Tiers 105
Two Tiers, Scorpius Outer Shell 175
Under Cover 203
Unfair Square 235
Unhappy Childhood 68
Uni 15
Union Square 221
Universal Block 250
Up or Down 285
Vanishing Trunk 191
Vega 72
Venus 181
Victor 206
Windmill 170
Window Pain 194
Wunder Bar 16
X-ercise 223
Yogi Burr 131
Z-Puzzle 13